



# iPLAN<sup>®</sup> STEREOTAXY

Version 3.0

**Software User Guide**  
**Revision 1.4**

Copyright 2014, Brainlab AG Germany. All rights reserved.



# TABLE OF CONTENTS

<b>GENERAL INFORMATION</b> .....	9
<b>Contact Data &amp; Legal Information</b> .....	9
Legal Information .....	10
<b>Symbols</b> .....	11
<b>Intended Use</b> .....	12
<b>Compatibility with Medical Devices</b> .....	13
Brainlab Medical Software.....	14
Non-Brainlab Medical Devices .....	15
Non-Brainlab Software .....	16
<b>Training and Documentation</b> .....	17
Used Abbreviations.....	18
<b>LOADING AND IMPORTING PATIENT DATA</b> .....	19
<b>Software Startup</b> .....	19
Logfiles .....	22
Load and Import Steps.....	23
<b>Creating New Archives</b> .....	24
Settings for the New Archive - Overview .....	25
Settings for the New Archive - Advanced Brainlab Format .....	26
Settings for the New Archive - DICOM .....	27
Settings for the New Archive - DICOM PACS Import .....	29
Settings for the New Archive - MR Analyze .....	30
<b>Selecting an Archive</b> .....	32
<b>Handling Patient Data</b> .....	33
Copying or Moving Patient Data to a Different Archive.....	35
Loading a Treatment Plan .....	37
Importing DICOM Data .....	38
Importing DICOM BOLD/DTI Data .....	41
Orientation .....	43
Deleting Slices .....	45
Sorting Images.....	46
DICOM Information .....	47
<b>Adding Patient Data</b> .....	48
<b>iPLAN STEREOTAXY WORKFLOWS</b> .....	49

<b>Example Framebased Procedures</b> .....	49
Functional Planning Workflow .....	50
Postoperative Study Workflow.....	52
<b>Example Frameless Procedures</b> .....	53
<b>APPLICATION OVERVIEW</b> .....	55
<b>Introduction to iPlan</b> .....	55
Image Data and Abbreviations .....	56
<b>User Interface</b> .....	58
Overview of Dialogs .....	59
The Navigator Area.....	60
The iPlan Navigator.....	61
The Functions Area .....	62
Tab Pages .....	64
Image Views in the Planning Area.....	65
Toolbar and Function Buttons.....	67
Mouse/Keyboard Shortcuts.....	70
<b>CONFIGURING VIEWS</b> .....	73
<b>Configuring Individual Views</b> .....	73
Full Screen.....	75
View Orientation.....	76
View Types.....	77
Composing Options.....	79
<b>Image View Tabs</b> .....	82
Slice View Tabs.....	84
X-ray Images Tab.....	86
Multiple Sets Tab.....	87
<b>Plan Content Tab</b> .....	88
Image Sets .....	89
Planned Content .....	91
<b>ADVANCED 3D FEATURES</b> .....	93
<b>Introduction</b> .....	93
<b>Advanced 3D Viewing</b> .....	94
Parallel 2D/3D Viewing .....	98
<b>Advanced 3D Thresholding</b> .....	99
<b>Advanced 3D Clipping</b> .....	101
<b>LOCALIZATION</b> .....	103
<b>Introduction</b> .....	103

Guideline for Performing Localization .....	104
<b>Localizing the Image Set</b> .....	106
Localization Result .....	107
<b>Localization Functions</b> .....	110
Adding and Positioning Rod Markers .....	111
<b>STEREOTACTIC LOCALIZERS</b> .....	113
<b>Rod Marker Geometries</b> .....	113
Brainlab Localizer .....	114
Leksell Localizers .....	115
Radionics Localizers .....	116
Fischer Localizers .....	118
<b>SUPPORTED ARC SYSTEMS</b> .....	121
<b>Brainlab Stereotactic System</b> .....	121
<b>Elekta Leksell Micro-Stereotactic Systems</b> .....	123
Leksell Standard Stereotactic Arc .....	124
Leksell Multi Purpose Stereotactic Arc .....	125
<b>Fischer Leibinger Arc System</b> .....	128
Arc System Settings: Upmount Orientation .....	129
Arc System Settings: Downmount Orientation .....	131
<b>AC/PC LOCALIZATION</b> .....	133
<b>Introduction</b> .....	133
AC/PC Localization Functions .....	134
<b>Performing AC/PC Localization</b> .....	135
<b>PLANNING REGISTRATION POINTS</b> .....	137
<b>Introduction</b> .....	137
Registration Points Functions .....	138
<b>Planning Points</b> .....	139
Defining Donut Markers .....	140
Defining Detection Parameters for Sphere Markers .....	142
Automatically Detecting Sphere Markers .....	144
Additional Functions .....	146
<b>IMAGE FUSION</b> .....	147
<b>Introduction</b> .....	147
Image Fusion Functions .....	148
<b>Selecting Images for Fusion</b> .....	149

<b>Optimizing the Image Display</b> .....	151
Adjusting Image Windowing .....	152
<b>Performing Image Fusion</b> .....	153
Automatic Fusion .....	155
Frame of Reference Fusion .....	156
Fusion by Volumetric Information .....	157
Manual Fusion .....	158
Registration Points Fusion .....	160
<b>Fusion Accuracy</b> .....	161
<b>OBJECT CREATION</b> .....	163
<b>Introduction</b> .....	163
Object Creation Functions .....	164
<b>Adding Objects</b> .....	165
Adding Multiple Objects .....	167
<b>Creating Objects</b> .....	168
Creating Objects Using the SmartBrush .....	171
Creating Objects Using the SeedBrush .....	172
<b>Creating Objects Using Automatic Segmentation</b> .....	174
Automatic Segmentation with Band Thresholding (Using a Region of Interest) .....	177
Automatic Segmentation with Band Thresholding (Using a Mask Object) .....	179
<b>Creating High Resolution Objects</b> .....	180
Verifying High Resolution Objects .....	183
<b>Correcting Objects</b> .....	184
<b>Advanced Object Manipulation</b> .....	185
Scaling Objects .....	186
Merging Objects .....	188
Splitting Objects .....	190
<b>Object Properties</b> .....	192
<b>Additional Functions</b> .....	194
<b>Preparing Objects for Export</b> .....	196
<b>BOLD MRI MAPPING</b> .....	197
<b>Introduction</b> .....	197
BOLD MRI Image Processing .....	199
BOLD MRI Mapping Functions .....	201
<b>BOLD MRI Mapping</b> .....	202
Defining the Design Matrix .....	203
Analyzing BOLD MRI Data .....	205
<b>Time Series View Tab</b> .....	207

Signal Display .....	209
Motion Correction.....	211
<b>3D BOLD MRI Objects</b> .....	212
Creating 3D BOLD MRI Objects.....	213
<b>FIBER TRACKING</b> .....	217
<b>Introduction</b> .....	217
Fiber Tracking Functions.....	218
<b>Using Fiber Tracking</b> .....	219
Defining the Region of Interest for Tracking .....	220
Adjusting the Tracking Parameters.....	223
Tracking Fibers .....	224
<b>3D Fiber Objects</b> .....	226
<b>STEREOTACTIC PLANNING</b> .....	229
<b>Introduction</b> .....	229
Stereotactic Planning Functions .....	230
<b>Creating Trajectories</b> .....	231
Duplicating Trajectories .....	232
Creating Parallel Trajectories .....	233
<b>Arc Settings</b> .....	234
Using Arc Settings .....	235
<b>AC/PC Coordinates</b> .....	236
Positioning Target and Entry Points .....	237
<b>Atlas Planning</b> .....	238
Using the Atlas.....	239
<b>Additional Functions</b> .....	241
General Functions.....	244
<b>Trajectory Display and Verification</b> .....	245
Verifying Trajectories .....	248
<b>ELECTRODE RECORDING</b> .....	251
<b>Introduction</b> .....	251
Electrode Recording Functions .....	252
<b>Planning Parallel Tracks</b> .....	253
Track Planning Relative to the Stereotactic Arc.....	254
Applying Planned Tracks to the Arc System .....	255
Planning New Tracks .....	258
Verifying Tracks.....	260
Track Display and Position .....	261
<b>Entering MER/S Data</b> .....	263

Entering Data .....	264
Viewing Displayed MER/S Data .....	267
Working with Templates .....	269
MER/S Data Backup .....	271
<b>TOOLBAR FUNCTIONS</b> .....	<b>273</b>
<b>Introduction</b> .....	<b>273</b>
<b>Selecting an Image Set</b> .....	<b>274</b>
<b>General Options</b> .....	<b>275</b>
Viewing Options .....	276
3D Thresholding .....	280
3D Clipping .....	281
<b>Viewing Images</b> .....	<b>283</b>
Pan and Recenter .....	284
Zooming Images .....	285
<b>Windowing</b> .....	<b>286</b>
Advanced Windowing .....	287
<b>Measurement Functions</b> .....	<b>291</b>
Distance and Angle Measurement .....	293
<b>Labeled Points</b> .....	<b>294</b>
<b>Screenshots</b> .....	<b>296</b>
<b>SAVING PLANS</b> .....	<b>297</b>
<b>Saving a Treatment Plan</b> .....	<b>297</b>
Saving Changes .....	298
Changing Directory Settings .....	300
<b>Saving a Plan for Use with iPlan RT Image</b> .....	<b>301</b>
<b>EXPORTING THE PLAN AND CLOSING iPLAN</b> .....	<b>303</b>
<b>Exporting: Standard Brainlab Format</b> .....	<b>303</b>
Additional Export Information .....	307
<b>Exporting: DICOM PACS</b> .....	<b>309</b>
<b>Closing the Software</b> .....	<b>311</b>
<b>iHELP (REMOTE CUSTOMER SUPPORT)</b> .....	<b>313</b>
<b>Introduction</b> .....	<b>313</b>
<b>INDEX</b> .....	<b>315</b>



# 1 GENERAL INFORMATION

## 1.1 Contact Data & Legal Information

### Contact Data

---

#### Support

If you cannot find information you need in this guide, or if you have questions or problems, contact Brainlab support:

Region	Telephone and Fax	Email
United States, Canada, Central and South America	Tel: (800) 597-5911 Fax: (708) 409-1619	us.support@brainlab.com
Brazil	Tel: (0800) 892-1217	
UK	Tel: +44 1223 755 333	support@brainlab.com
Spain	Tel: +34 (900) 649 115	
France and French-speaking regions	Tel: +33 800 676 030	
Africa, Asia, Australia, Europe	Tel: +49 89 991568-44 Fax: +49 89 991568-811	
Japan	Tel: +81 3 3769 6900 Fax: +81 3 3769 6901	

---

#### Expected Service Life

Brainlab provides five years of service for software. During this period of time, software updates as well as field support are offered.

---

#### Feedback

Despite careful review, this manual may contain errors. Please contact us at [igs.manuals@brainlab.com](mailto:igs.manuals@brainlab.com) if you have suggestions as to how we can improve this manual.

---

#### Manufacturer

Brainlab AG  
Olof-Palme-Str. 9  
81829 Munich  
Germany

## 1.1.1 Legal Information

---

### Copyright

This guide contains proprietary information protected by copyright. No part of this guide may be reproduced or translated without express written permission of Brainlab.

---

### Brainlab Trademarks

- **iPlan**<sup>®</sup> is a registered trademark of Brainlab AG in Germany and/or the US
  - **Kolibri**<sup>™</sup> is a trademark of Brainlab AG, registration pending
  - **Smart Brush**<sup>®</sup> is a registered trademark of Brainlab AG in Germany and/or the US
  - **VectorVision**<sup>®</sup> is a registered trademark of Brainlab AG in Germany and/or the US
- 

### Non-Brainlab Trademarks

- Microsoft<sup>®</sup> and Windows<sup>®</sup> are registered trademarks of Microsoft Corporation.
- 

### Integrated 3rd-Party Software

- This software is based in part on the work of the Independent JPEG Group.
  - Portions of this software are based on the work of Sun Microsystems Inc.
  - This product includes software developed by the Apache Software Foundation ([www.apache.org/](http://www.apache.org/)).
  - **iPlan 3.0** requires Java 2 Runtime Environment (version 1.4 or higher) installed on the system.
  - The Brainlab PDF-Viewer implementation is based on the PDF Direct/PDF Quick View library, Copyright 2003-2011 soft Xpansion GmbH & Co. KG.
- 

### CE Label



The CE label shows that the Brainlab product complies with the essential requirements of the Medical Device Directive (MDD).

According to the MDD, Council Directive 93/42/EEC, **iPlan Stereotaxy** is a Class IIb product.

*NOTE: The validity of the CE label can only be confirmed for products manufactured by Brainlab.*

---

### Disposal Instructions

	Only dispose of electrical and electronic equipment in accordance with statutory regulations. For information regarding the WEEE (Waste Electrical and Electronic Equipment) directive, visit: <a href="http://www.brainlab.com/weee">http://www.brainlab.com/weee</a>
---	---

---

### Sales in the US

US federal law restricts this device to sale by or on the order of a physician.

## 1.2 Symbols

### Symbols Used in This Guide

---

#### Warnings



Warnings are indicated by triangular warning symbols. They contain safety-critical information regarding possible injury, death or other serious consequences associated with equipment misuse.

---

#### Cautions



Cautions are indicated by circular caution symbols. They contain safety-critical information regarding possible problems with the device. Such problems include device malfunctions, device failure, damage to device or damage to property.

---

#### Notes

*NOTE: Notes are formatted in italic type and indicate additional useful hints.*

## 1.3 Intended Use

### Using the System

---

#### Indications for Use

**iPlan**'s indications for use are the viewing, presentation, and documentation of medical imaging, including different modules for image processing, image fusion, atlas assisted visualization and segmentation, intraoperative functional planning where the output can be used e.g. with stereotactic image guided surgery or other devices for further processing and visualization.

Example procedures include, but are not limited to:

- Planning and simulation of cranial surgical procedures such as tumor resection, shunt placement, minimal-invasive stereotactic interventions, biopsy, planning, and simulation of trajectories for stimulation and electrode recording.
- ENT procedures such as sinus surgery, tumor surgery.
- Spine procedures such as tumor surgery, pedicle screw planning, vertebroplasty planning.
- **iPlan View** is an application which is intended to be used for reviewing existing treatment plans.
- Planning and simulation of cranial-maxillofacial procedures

Typical users of **iPlan** are medical professionals, including but not limited to surgeons and radiologists

---

#### Intended User

The intended software users are surgeons and medical professionals.

---

#### Place of Use

The place of use is determined to be indoors, normally in a hospital or clinical setting.

---

#### Careful Handling



**Only trained medical personnel may operate system components and accessory instrumentation.**

---

#### Plausibility Review



**Before patient treatment, review the plausibility of all information input to and output from the system.**

---

#### Responsibility



**This system solely provides additional assistance to the surgeon or user and does not by any means substitute or replace the surgeon's or user's experience and/or responsibility during its use.**

## 1.4 Compatibility with Medical Devices

### Brainlab Medical Instruments

---

#### Compatible Brainlab Medical Instruments

**iPlan Stereotaxy** is compatible with:

- Brainlab CT/X-Ray Localizer Rev. 1 (Interfaces with the Brainlab Heading for Arc)
  - Brainlab Stereotactic Arc Rev. 1 (Interfaces with the Brainlab Heading for Arc)
- 

#### Other Brainlab Instruments

Additional instrumentation may become available after release of this manual. Contact Brainlab support if you have any questions regarding instrument compatibility with Brainlab software.



**Only use instruments and spare parts specified by Brainlab with iPlan Stereotaxy. Using unauthorized instruments/spare parts may adversely affect safety and/or effectiveness of the medical device and endanger safety of patient, user and/or environment.**

## 1.4.1 Brainlab Medical Software

---

### Compatible Brainlab Medical Software

**iPlan Stereotaxy** is compatible with:

- PatXfer software version 5.2
- VectorVision cranial software versions 7.0, 7.5, 7.6, 7.7, 7.8 and 7.9
- cranial/ENT essential & unlimited software version 1.0
- cranial/ENT unlimited version 2.0 and 2.1
- Kolibri cranial software versions 2.1, 2.5, 2.6 and 2.7
- iPlan Cranial software versions 1.1, 1.5, 2.5, and 2.6
- iPlan Stereotaxy/Cranial/ENT software versions 1.1, 2.5, and 2.6
- iPlan RT Image software version 4.1
- Universal DICOM Transfer
- Content Manager 2.0
- Patient Browser 4.0
- DICOM Viewer 2.0

---

### Other Brainlab Software

Other compatible Brainlab software may become available after the release of this user guide. If you have questions regarding compatibility of software contact Brainlab support.

If you are running software versions other than those specified above, contact Brainlab support for clarification regarding compatibility with Brainlab devices.



**Unauthorized manipulation of the iPlan system files or patient data files is forbidden. Contact Brainlab support for servicing all iPlan-related files or configuration settings.**

## 1.4.2 Non-Brainlab Medical Devices

### Compatible Non-Brainlab Medical Devices

Manufacturer	Medical Device	
Leksell/Elekta	Stereotactic localizer	Leksell CT Indicator Box or Leksell MR Indicator Box interfacing with Leksell G-Frame Headring
	Arc system	Leksell Multi Purpose Stereotactic Arc or Leksell Standard Stereotactic Arc interfacing with Leksell G-Frame Headring
Radionics	Stereotactic localizer	Radionics MR1A-2-LF (MR-Localizer Frame), Radionics Luminant or Radionics UCLF-0 (Universal Compact CT/MR Localizer Frame) interfacing with Radionics UCHR (Universal Compact Headring)
	Stereotactic localizer	Radionics BRW-LR (Brown, Cosman and Wells CT Localizer Ring) interfacing with Radionics HRA-IM (Intubation Headring) or Radionics UCHR (+Radionics UCHR A
	Arc system	Radionics CRW ASL (Arc System identical with non-light-weight CRW AS) interfacing with Radionics UCHR (+Radionics UCHR AP) or Radionics HRA-IM
Fischer	Stereotactic localizer	Revision O CT Localizer or Revision A CT Localizer interfacing with Titanium Headring Revision U (OSS) CT/MR Localizer interfacing with OSS Open Ceramic Headring
	Arc system	Fischer ZD interfacing with OSS Open Ceramic Headring or Titanium Headring

### Other Non-Brainlab Devices



**Using medical device combinations which have not been authorized by Brainlab may adversely affect safety and/or effectiveness of the devices and endanger safety of patient, user and/or environment.**

### 1.4.3 Non-Brainlab Software

---

#### Other Non-Brainlab Software

**iPlan Stereotaxy** is compatible with Microsoft Windows XP, Server 2003/2008, Windows 7 and Windows 8 operating systems. For detailed and up-to-date information regarding compatible operating systems, please contact Brainlab support.

Brainlab recommends protecting the system by state-of-the-art malware protection measures (e.g. installation of a virus scanner). Be aware that some malware protection measures can negatively affect the system performance e.g., if realtime scans are performed and each file access is monitored, then loading and saving patient data may be slow.

*NOTE: The Brainlab system is a medical device and shall be used according to the intended use and the end user license agreement of the system. Using third party software can adversely affect the reliability of the system.*



**Only critical operating system updates or malware protection measures are recommended. Driver updates are not allowed. Do not download or install updates during treatment planning. Please contact Brainlab support for further information.**

---

#### DICOM Conformance

DICOM conformance statements can be found on the Brainlab homepage: [www.brainlab.com](http://www.brainlab.com)

---

#### Medical Electrical Systems

For information regarding the configuration of medical electrical systems, see the relevant **System User Guide** and **Technical User Guide**.



## 1.5 Training and Documentation

### Overview

---

#### Intended Audience

This user guide is intended for surgeons and/or their staff.

---

#### Brainlab Training

To ensure safe and appropriate use, before using the system all users should participate in a training program held by a Brainlab representative.

---

#### Documentation

This guide describes complex medical software that must be used with care. It is therefore important that all users of the system:

- Read this guide carefully before handling the equipment
  - Have access to this guide at all times
- 

#### Available User Guides

User Guide	Contents
Software User Guides	<ul style="list-style-type: none"> <li>• Overview of treatment planning and image-guided navigation</li> <li>• Description of OR system setup</li> <li>• Detailed software instructions</li> </ul>
Instrument User Guides	Detailed instructions on instrument handling
Cleaning, Disinfection and Sterilization Guide	Details on cleaning, disinfecting and sterilizing instruments
System User Guides	Comprehensive information on system setup
Technical User Guides	Detailed technical information on the system, including specifications and compliances

## 1.5.1 Used Abbreviations

---

### Abbreviations

This user guide may contain the following abbreviations:

Abbreviation	Definition
ADC Trace Map	DTI Apparent Diffusion Coefficient
B0	DTI image acquired at $b=0$ sec/mm <sup>2</sup>
BOLD	Blood Oxygen Level Dependent
CT	Computed Tomography
DICOM	Digital Imaging and Communications in Medicine
DTI	Diffusion Tensor Imaging
FA	Fractional Anisotropy
FoR	Frame of Reference
HU	Hounsfield Unit
MER/S	Microelectrode Recording and Stimulation
MRI	Magnetic Resonance Imaging
NM	Nuclear Medicine
PACS	Picture Archiving and Communication System
PET	Positron Emission Tomography
SPECT	Single Photon Emission Computed Tomography
SUV	Standard Uptake Value
CSV	Comma Separated Values

# 2 LOADING AND IMPORTING PATIENT DATA

## 2.1 Software Startup

### Starting the Software

#### How to Start

Step	
	Double-click the <b>iPlan Stereotaxy</b> icon on the desktop to start the program and display the treatment plan selection screen.

#### Dialog Pages

Patient data can be loaded and imported using a series of dialog pages which also identifies the location where patient data is read from or saved to.

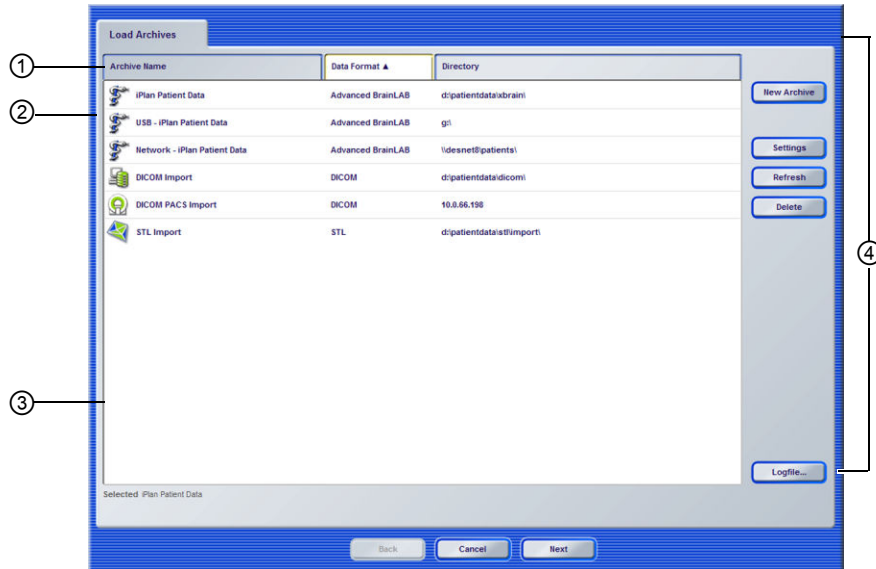



Figure 1

## Screen Layout

The screen layout overview displays file information and the location of where patient data is read from and saved to.

No.	Explanation	Explanation
①	List headers	 <p>Sort the list data according to any header by clicking the relevant header. Sort the data in ascending or descending order - the current order is indicated by arrow icons next to the header name.</p>
②	List of available data	Depending on the current step, this list allows you to select available patient data such as archive types, patient studies, or image series.
③	Details area	Provides supplementary information on the selected patient data.
④	Functions	Functions relevant for the dialog page.

## Dialog Functions

Functions that appear in general dialogs are listed below.

Function	Explanation
Back	Returns you to the previous step.
Cancel	Closes the current dialog.
Next	Branches you to the next step.
Archives	Returns you to archive selection.
Settings	Allows you to define specific settings for the selected archive. The available settings vary depending on the selected data format (see from page 25).
Delete	<p>Permanently deletes any selected files. The software asks for final confirmation before deleting any files.</p> <ul style="list-style-type: none"> <li>• Only patient data located on the hard disk can be deleted.</li> <li>• During patient selection, if the last patient is deleted, you are branched back to the archive page.</li> <li>• During study selection, if there is only one patient study, it cannot be deleted.</li> <li>• Deleting an archive only removes the entry from the archive list. No patient data is deleted.</li> </ul>
Refresh	Updates the display, e.g., when a new patient is added to the directory on the hard drive.
Logfile...	Displays a log file containing supplementary information on the steps completed so far (see page 22).
Select All	Selects all entries in the current list.
Deselect All	Deselects all entries in the current list.

## Deleting Data



**Selected data can be deleted from the hard disk even if it is set to read-only. If Quick Search is enabled (see page 27), the delete function removes all files and folders (including non-DICOM files) located in the patient folder. If Quick Search is disabled, the**

**delete function removes only files and folders related to one patient. Depending on your Alias Patient handling settings (see page 27), you may also be notified when two patients with the same ID but different names are found.**

## 2.1.1 Logfiles

---

### General Information

A logfile function is provided in certain data transfer dialogs. This allows logfiles generated by the system for the step in question to be displayed.

---

### How to Activate the Logfile Display

Step
Click <b>Logfile...</b> to the right of the dialog. The logfile opens in your default internet browser.

## 2.1.2 Load and Import Steps

---

### About the Procedure

Due to the variety of scanners and storage media available, it is not possible to discuss specific data formats or transfer procedures individually. This user guide explains the general procedure for converting patient data. Should specific questions or problems arise, contact Brainlab support for assistance.

---

### Treatment Plan Access

Each treatment plan can only be opened by one user at a time.

---

### Loading Multiple Plans

Only one treatment plan can be opened at a time. If you are already editing one treatment plan, and either load a second treatment plan or close the application without saving, you will lose any changes made to the first treatment plan.

---

### Loading Data from Removable Media or the Network



**If you load data from removable media (e.g., USB flash drive or DVD), and intend to remove the media during planning, or if you load data from a read-only drive, first save the treatment plan locally to another archive. Otherwise, important treatment plan information will be lost. Additionally, make sure to save the treatment plan locally if data has been loaded from a network. Otherwise, treatment plan information will be lost if connection to the network is interrupted.**

---

### Scanning Instructions

Detailed scanning instructions for your preferred modality and intended treatment combination are available from Brainlab support on request. To obtain the best possible results from your treatment planning system, it is strongly recommended to follow the instructions provided in the relevant scanning protocol.



**DICOM images must have a squared pixel size. There is no limitation for the matrix size. For export with the Brainlab format, it is recommended to use 512 x 512 pixels to avoid interpolation artefacts. Pixel size and matrix size have to be constant per series.**

## 2.2 Creating New Archives

### Getting Started

---

#### How to Activate Archive Creation

<b>Step</b>
-------------

Click <b>New Archive</b> in the functions area of the <b>Load Archives</b> dialog that is displayed upon software startup (see page 32).
--

---

#### How to Select the Archive Type

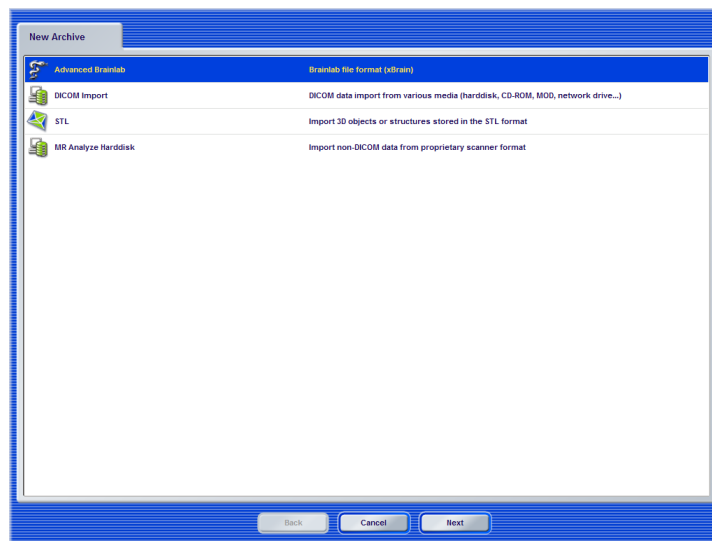

Figure 2

<b>Steps</b>
--------------

- |   |
|---|
| 1. Select the archive type by clicking on the corresponding name or icon. |
| 2. Click <b>Next</b> to define the settings.                              |

*NOTE: Only enabled (licensed) data format types are listed in the **New Archive** dialog.*



## 2.2.1 Settings for the New Archive - Overview

---

### Available Settings Pages

Depending on the selected archive type, you are prompted to enter specific information and/or to define particular settings.

The settings can be adjusted at any time by clicking **Settings** in the **Load Archives** dialog.

Archive Type	Explanation	See
Advanced Brainlab	Brainlab file format (xBrain)	Page 26
DICOM import from file system	DICOM import from various media	Page 27
MR Analyze	Import non-DICOM data from proprietary scanner format	Page 30

*NOTE: DICOM format includes modalities such as MR, CT, PET, SPECT, XR or XA. X-ray Angiography (3D) data sets are imported as XT modality.*

## 2.2.2 Settings for the New Archive - Advanced Brainlab Format

### General Information

This archive is used to save treatment plans created in **iPlan**.

### How to Define Settings

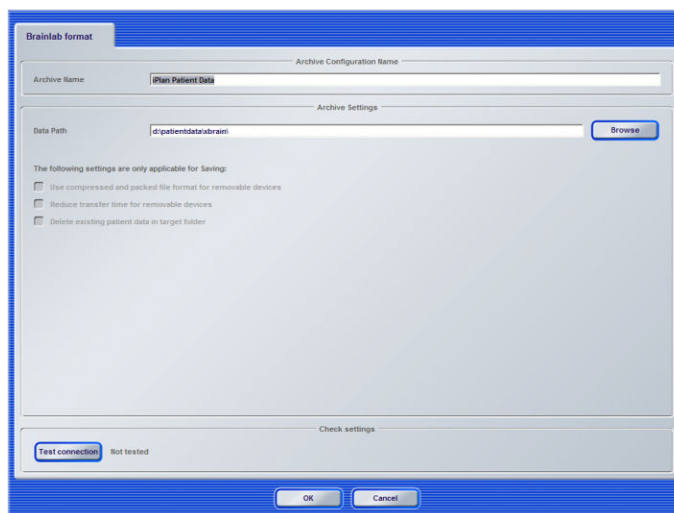

Figure 3

Steps	
1.	Enter a name for the archive in the <b>Archive Name</b> field.
2.	In the <b>Data Path</b> field, click <b>Browse</b> to navigate to the relevant network or local path. Alternatively, enter the file path for the patient data manually.
3.	Enable the relevant check boxes to apply applicable settings for saving: <ul style="list-style-type: none"> <li>• <b>Use compressed and packed file format for removable devices:</b> Speed up archiving on removable USB drives.</li> <li>• <b>Reduce transfer time for removable devices:</b> Speed up archiving on removable devices by omitting raw data that is not used by navigation.</li> <li>• <b>Delete existing patient data in target folder:</b> Cleans up the removable device.</li> </ul>
4.	To verify that the file path is valid, click <b>Test connection</b> .
5.	Click <b>OK</b> to return to the <b>Load Archives</b> dialog where you can load the archive (see page 32).

### 2.2.3 Settings for the New Archive - DICOM

#### General Information

This archive is used for DICOM data import from a file system (e.g., CD-ROM, DVD, hard disk, removable device, network path).

#### How to Define Settings

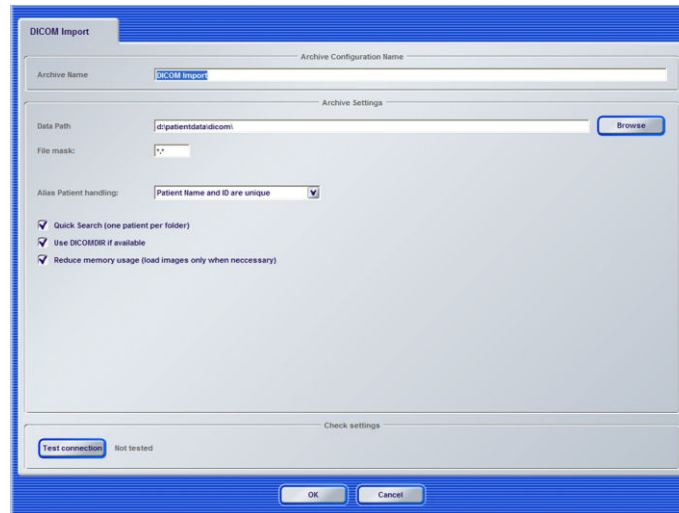

Figure 4

Steps	
1.	Enter a name for the archive in the <b>Archive Name</b> field.
2.	In the <b>Data Path</b> field, click <b>Browse</b> to navigate to the relevant network or local path. Alternatively, enter the file path for the patient data manually.
3.	Define <b>Alias Patient handling</b> settings (see page 27).
4.	Enable the relevant check boxes: <ul style="list-style-type: none"> <li>• <b>Quick Search:</b> The system assumes that only one patient exists in every folder and only takes files and folders related to one patient into account</li> <li>• <b>Use DICOMDIR:</b> Speeds up browsing of DICOM data</li> <li>• <b>Reduce memory usage:</b> If selected, the software initially only loads header information when importing DICOM data. This considerably reduces the load time. The image data is then loaded when selected during image set selection (see page 274).</li> </ul>
5.	To verify that the file path is valid, click <b>Test connection</b> .
6.	Click <b>OK</b> to return to the <b>Load Archives</b> dialog where you can load the archive (see page 32).

#### Alias Patient Handling

Under **Alias Patient handling** you can configure archive creation settings.

Function	Explanation
Patient ID is unique	Select this if all patients with the same patient ID shall be considered identical
Patient Name and ID are unique	Select this if the patient name and the patient ID match for a patient folder

<b>Function</b>	<b>Explanation</b>
Ask user	Select this to prompt how to proceed for patients with the same ID but a different name

## 2.2.4 Settings for the New Archive - DICOM PACS Import

---

### General Information

This archive is automatically created and configured to facilitate the import of DICOM data from a query/retrieve system. Please contact Brainlab support to configure additional PACS systems if needed.

## 2.2.5 Settings for the New Archive - MR Analyze

### MR Analyze Harddisk - Overview

**MR Analyze Harddisk** archives are primarily used to interface functional MRI data. Transfer of this data type is similar to other data transfer procedures in terms of configuration, patient selection, transfer and storage. Brainlab support will perform the configuration and provide additional user training.

An MR Analyze patient image series contains two data files:

- The patientName.hdr file; containing the image header with parameters related to the image volume
- The patientName.img file; the image file corresponding to the header file

The MR Analyze patient data must be copied to the defined MR Analyze folder on the computer hard disk.

Usually this is C:/Brainlab/Analyze, however, the data source may also be located on CD-ROM, floppy disk or on the network. If in doubt, contact Brainlab support.



**The names of the \*.hdr and \*.img files must be the same. If one of the corresponding files is missing, the patient data cannot be transferred.**



**The names of the \*.hdr and \*.img files represent the patient name. As the patient name used in iPlan is derived from these file names, you must ensure that they contain the real patient name.**



**The user must manually adjust the modality if MR is not the correct image format.**



**Analyze data format does not contain information on the image or patient orientation. Verify and correct the orientation in the image preview in the Orientation dialog (click the Manipulation button, see page 43).**

### Harddisk Transfer Dialog

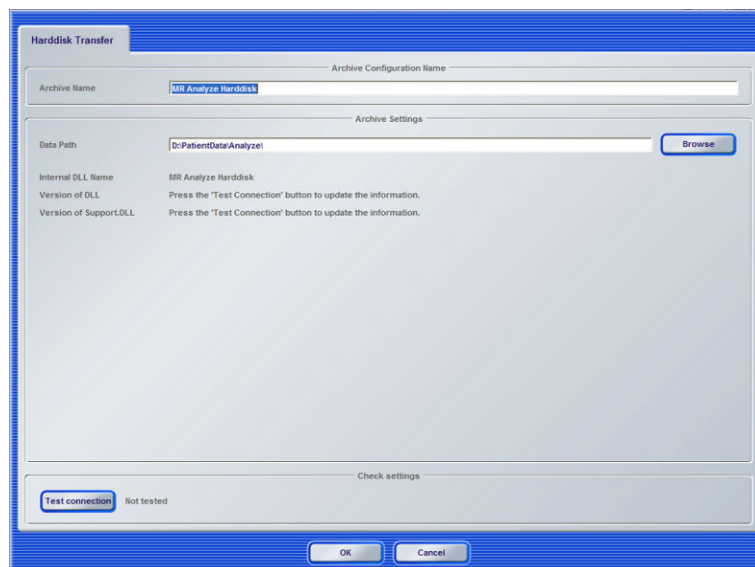

Figure 5

---

**How to Define Settings**

<b>Steps</b>	
1.	Enter a name for the archive in the <b>Archive Name</b> field.
2.	In the <b>Data Path</b> field, click <b>Browse</b> to navigate to the relevant network or local path. Alternatively, enter the file path for the patient data manually.
3.	To verify that the file path is valid, click <b>Test connection</b> .
4.	Click <b>OK</b> to return to the <b>Load Archives</b> dialog where you can load the archive (see page 32).

## 2.3 Selecting an Archive

### Archive Selection

#### How to Load an Archive

Once you have created an archive, it is available in the **Load Archives** dialog.

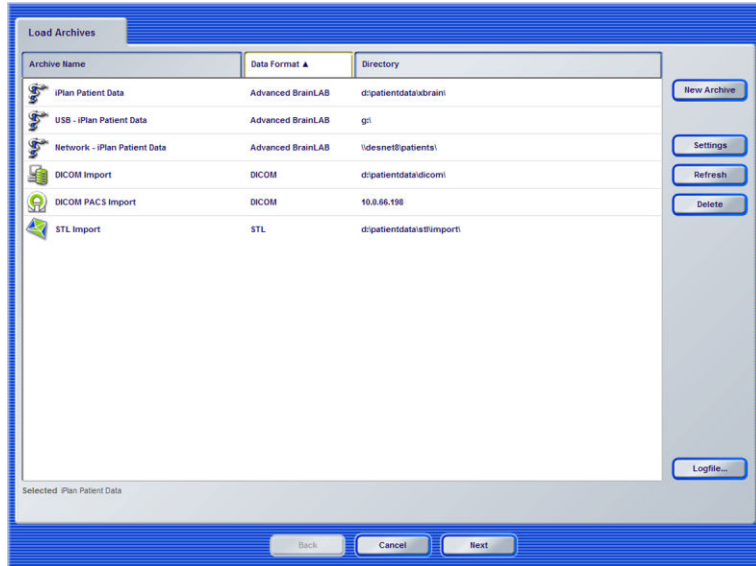

Figure 6

Steps	
1.	Select the archive by clicking on the corresponding name or icon.
2.	Click <b>Next</b> to display the patient data contained in the archive.

#### Functions for Archive Selection

Function	Explanation
New Archive	If a suitable archive has not yet been configured, this function allows one to be created for the data format you wish to transfer (see page 24).
Settings	Define specific settings for the selected archive. The available settings vary depending on the selected data format (see from page 25).
Delete	Deletes the selected archive. The patient data on the source file will not be removed.



## 2.4 Handling Patient Data

### Selecting a Patient

#### How to Select the Patient

Once an archive has been selected, the patient selection dialog is shown.

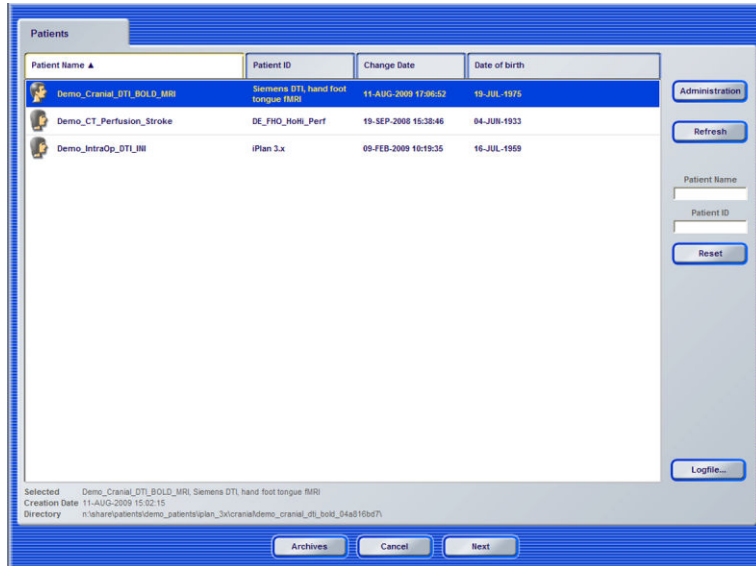

Figure 7

Steps
1. Select the patient file by clicking the corresponding name or icon.
2. Click <b>Next</b> to proceed.



**If the patient name or ID is not correctly entered on the scanner, these items are automatically set to Unknown. Please verify the selected patient data is correct.**

#### Patient Icons

Treatment Plan Icons	
	Indicates an anonymized patient
	Indicates female patient
	Indicates a male patient

---

**Functions for Patient Selection**

<b>Function</b>	<b>Explanation</b>
Administration	Manage patient data: <ul style="list-style-type: none"><li>• Create a copy of the patient file in a different archive (see page 35)</li><li>• Move the patient file to a different archive (see page 35)</li><li>• Permanently delete selected files (see page 20)</li></ul>
Refresh	Updates the display, e.g., when a new patient is added to the directory on the hard drive
Search	Filters the display according to the <b>Patient Name</b> or <b>Patient ID</b> entered
Reset	Resets the filter so that all available data is displayed again

## 2.4.1 Copying or Moving Patient Data to a Different Archive

### Available Functions

The **Copy** and **Move** functions are provided on the right of the **Administration** dialog when you click the **Administration** button (see page 33).

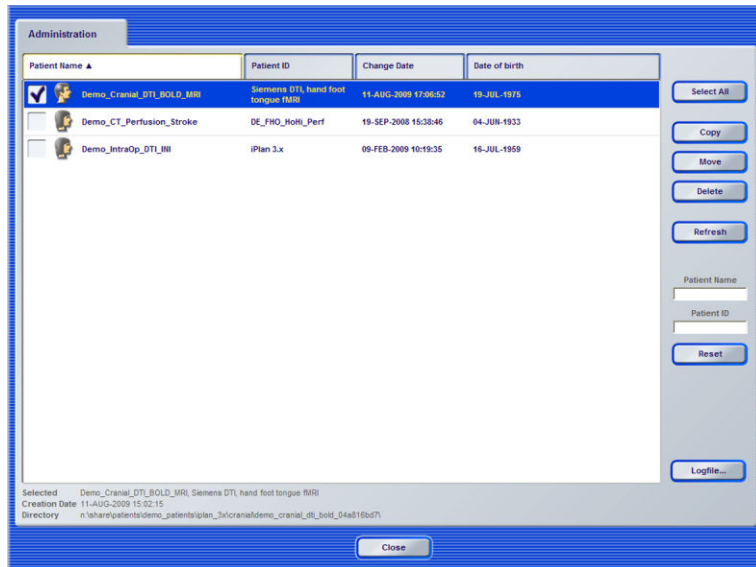

Figure 8

*NOTE: These functions are only available for DICOM and Advanced Brainlab formats.*

*NOTE: In order to use these functions, at least two archives of the selected type must be available. Details on archive creation are provided on page 24.*

### How to Copy or Move the Patient

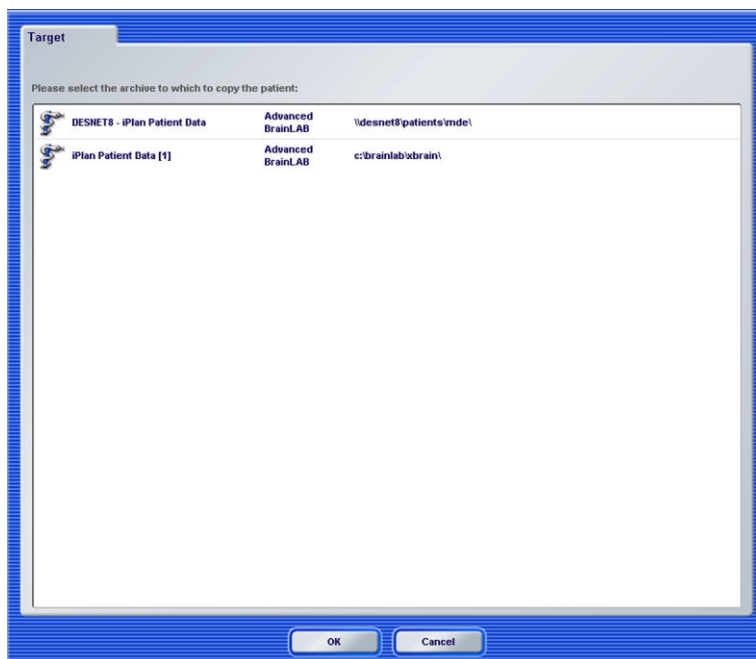

Figure 9

<b>Steps</b>	
1.	Highlight the patient file in the <b>Administration</b> dialog.
2.	Click <b>Copy</b> or <b>Move</b> to open the <b>Target</b> dialog (shown above).
3.	Highlight the archive.
4.	Click <b>OK</b> to transfer the data.

---

### **Transfer Status**

You are now returned to the **Administration** dialog where the status of the transfer action is indicated by a progress bar.

## 2.4.2 Loading a Treatment Plan

### Plans Dialog

If an advanced Brainlab archive has been selected, you are prompted to select a treatment plan.

*NOTE: If only one treatment plan is available, the system automatically opens it and proceeds to the next step.*

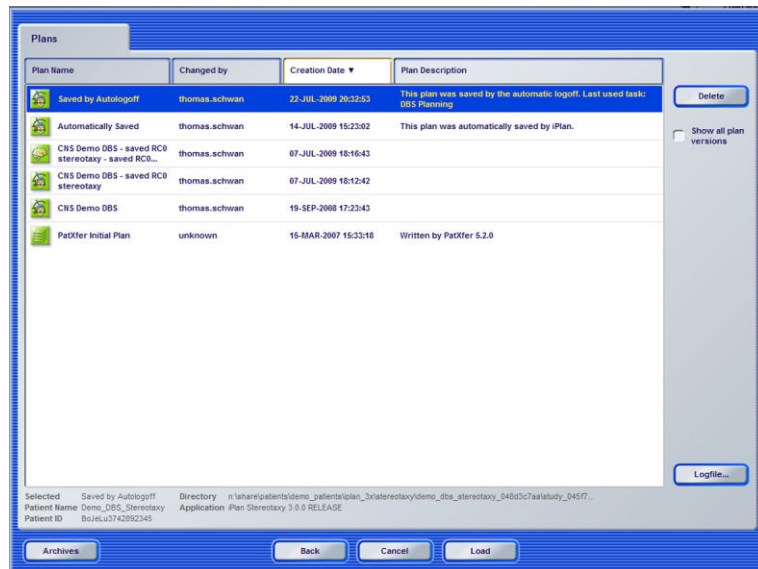

Figure 10

### How to Select the Treatment Plan

#### Steps

1. Select the treatment plan by clicking on the corresponding name or icon.
2. Click **Load** to load the treatment plan.

### 2.4.3 Importing DICOM Data

#### How to Select the Study

If you are importing DICOM data, and the loaded patient data contains multiple studies, you are prompted to select a patient study.

*NOTE: If only one patient study is available, the system automatically opens it and proceeds to the next step.*

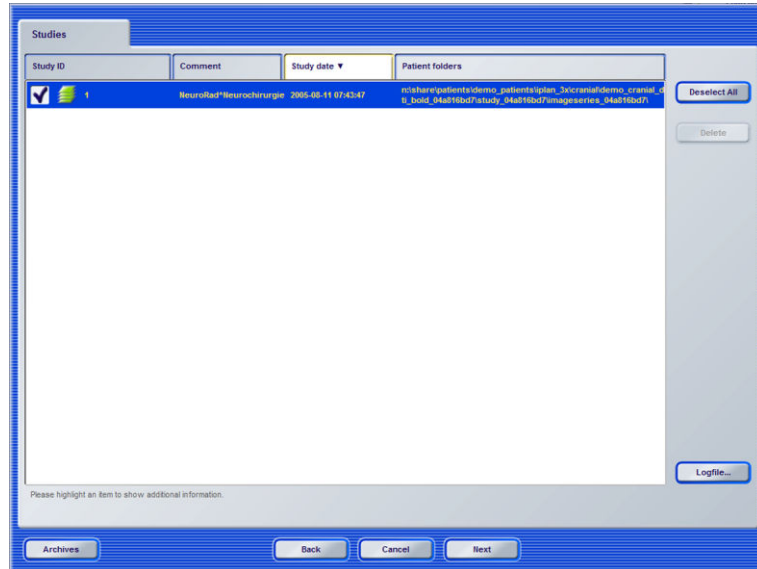

Figure 11

Steps
1. Select the patient study by clicking on the corresponding name or icon.
2. Click <b>Next</b> to proceed to image series selection.

#### How to Select the Image Series

You are now prompted to select the image series. The image series includes all image data saved to a specific study for an individual patient.

*NOTE: If only one image series is available, the system automatically opens it and proceeds to the next step.*

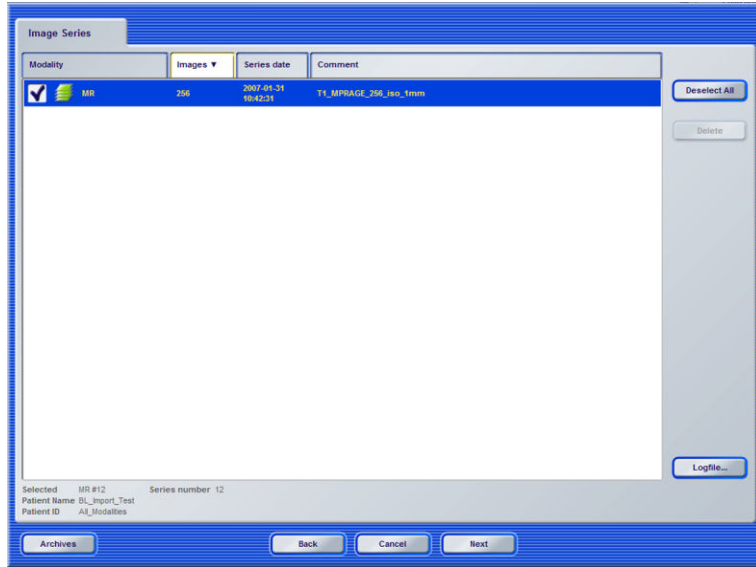

Figure 12

Steps	
1.	Select the image series by clicking on the corresponding name or icon.
2.	Click <b>Next</b> to proceed to image set selection.

**Advanced Data Dialog**

The following **Advanced Data** dialog opens. Here you can select the image set and apply settings.

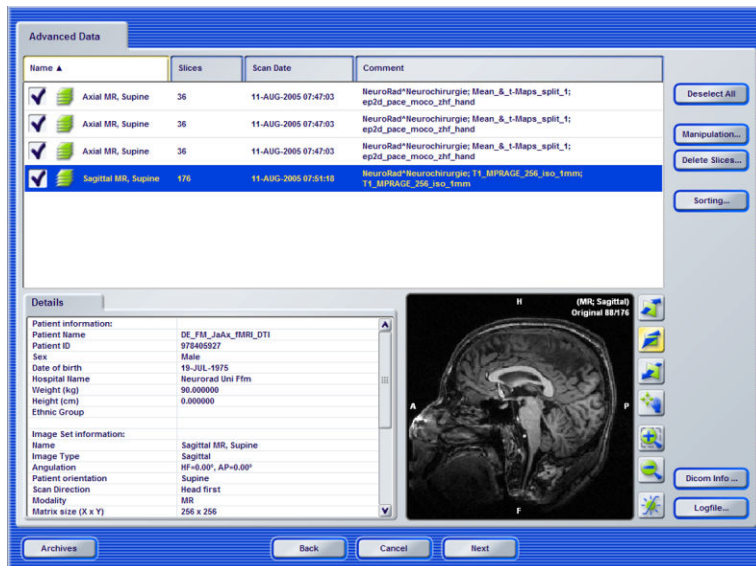

Figure 13

**Advanced Data Functions**

The following advanced functions are provided on the right of the **Advanced Data** dialog:

Function	Explanation
Manipulation...	Adjust the orientation of the loaded images (see page 43)

Function	Explanation
Sorting...	Sort the image data according to specific criteria (see page 46)
Delete Slices...	Delete slices from the selected image set (see page 45)
Dicom Info...	Display DICOM information relating to the displayed image (see page 47)

*NOTE: These functions are only available for 3D datasets.*

---

### How to Select and Review the Image Set

Steps	
1.	Select the image set by clicking on the corresponding name or icon.
2.	Verify that the image set information provided bottom left of the screen is correct. The information provided varies, depending on the selected dataset.
3.	Review the image set for suitability using the toolbar functions to the right of the image view (see page 67).
4.	Click <b>Next</b> to proceed to the <b>iPlan Navigator</b> (see page 61).



## 2.4.4 Importing DICOM BOLD/DTI Data

### Advanced Data Dialog

If you are loading DICOM data that includes BOLD MRI or DTI image data, the following **Advanced Data** dialog opens. Here you can select the image set and apply settings.



Figure 14

*NOTE: Advanced DICOM functions (manipulation, sorting, DICOM info) are described on page 39).*

### How to Select Image and Review the Image Set

Steps	
1.	Select the image series by clicking on the corresponding name or icon.
2.	Verify that the image set information provided bottom left of the screen in the <b>Details</b> tab is correct. The information provided varies, depending on the selected image set.
3.	In the <b>Preprocessing</b> tab (see page 42), select the appropriate settings.
4.	Review the image set for suitability using the toolbar functions to the right of the image view (see page 67).
5.	Click <b>Next</b> to finalize data import and proceed to the <b>iPlan Navigator</b> (see page 61).

## Preprocessing Settings

The preprocessing settings provided in the **Preprocessing** tab allow you to improve the image quality and results. The import settings must be specified for each study separately.

Data Format	Settings
BOLD MRI	<ul style="list-style-type: none"> <li>• <b>Slice Acquisition Order:</b> Must be specified in order to correct for slice timing artefacts due to interleaved slice acquisition.</li> <li>• <b>Smoothing:</b> Provides a dimensional Gaussian smoothing function with a 3x3 kernel.</li> <li>• <b>Motion Correction:</b> Facilitates rigid 3-dimensional co-registration of all data sets to the first BOLD MRI volume. The motion correction is based on mutual information and reduces head motion artefacts in BOLD data.</li> <li>• <b>Preview:</b> Allows you to review the translation and rotation of the motion correction. The results are displayed as a graph and can be discarded by clicking <b>Reset</b>.</li> </ul> <p><i>NOTE: <b>Smoothing</b> and <b>Motion Correction</b> settings should only be adjusted if similar preprocessing steps have not been applied at the scanner. Otherwise, the quality of the data may deteriorate.</i></p>
DTI	<p><b>Correct for Eddy Currents:</b> Improves registration between the DTI volumes. This is useful as DTI images are susceptible to distortions caused by eddy currents induced by diffusion gradients. The artefacts created by the scanner can be described by shift, scale and shear, in the phase encode direction.</p>

## 2.4.5 Orientation

### General Information

If the patient was scanned in the axial (prone or supine) position but with the head tilted and with according gantry tilt, the labeling of the coronal-like scan data will not be displayed correctly by the navigation software. You can correct this by exporting the data from the scanner as a coronal data set, or relabeling the data from axial to coronal in **iPlan** using the features described on page 43.

*NOTE: Some scanners and medical information formats do not include image orientation information in the image header.*

### How to Access Orientation Functions

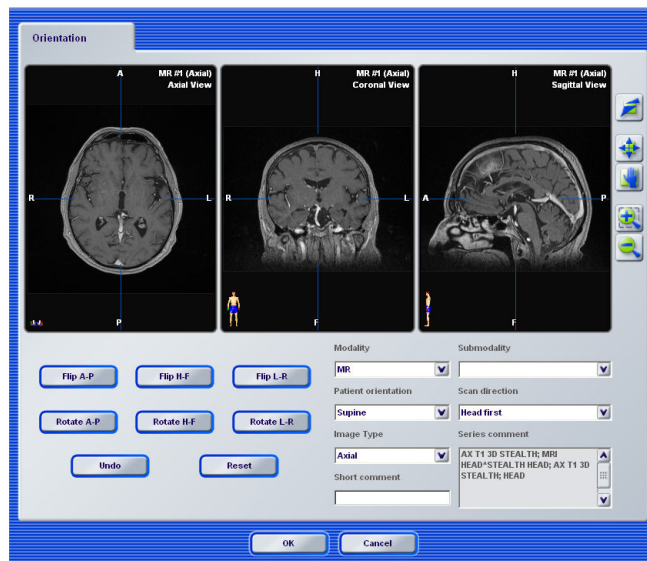

Figure 15

Steps	
1.	Select the required image set in the <b>Advanced Data</b> dialog (displayed once the data has been loaded).
2.	Click <b>Manipulation...</b> in the options area to the right of the dialog to open the <b>Orientation</b> dialog (shown above).

### Available Orientation Functions

Function	Explanation
<b>Flip A-P</b>	Flip the selected image in the <b>A-P</b> (anterior-posterior), <b>H-F</b> (head-foot), and <b>L-R</b> (left-right) directions
<b>Flip H-F</b>	
<b>Flip L-R</b>	
<b>Rotate A-P</b>	Rotate the selected image in the <b>A-P</b> (anterior-posterior), <b>H-F</b> (head-foot), and <b>L-R</b> (left-right) directions
<b>Rotate H-F</b>	
<b>Rotate L-R</b>	
<b>Undo</b>	Undo the last change made
<b>Reset</b>	Reset all changes made

Function	Explanation
<b>Modality</b>	The modality of the scan dataset ( <b>CT, MR, X-Ray, NM, XT, OT, or Ultra-sound</b> ) can be selected here if not already predefined on the scanner
<b>Submodality</b>	An appropriate submodality can be selected for the current modality, if not already predefined on the scanner: <ul style="list-style-type: none"> <li>• <b>CT</b> = Angio can be selected</li> <li>• <b>MR</b> = Angio, functional, T1, and T2 contrast can be selected</li> <li>• <b>X-Ray</b> = no sub-modality available</li> <li>• <b>NM</b> = PET and SPECT can be selected</li> <li>• <b>XT</b> = XA (angiography)</li> <li>• <b>OT</b> = SC can be selected</li> </ul>
<b>Patient orientation</b>	For the patient orientation, you can select <b>Prone, Supine, Decubitus Left, or Decubitus Right</b> if the orientation was not already predefined on the scanner. <i>NOTE: If <b>Unknown</b> has been automatically defined, ensure that the correct option for the image data is selected before continuing.</i>
<b>Scan direction</b>	Select either <b>Head first</b> or <b>Feet first</b> <i>NOTE: If <b>Unknown</b> has been automatically defined, ensure that the correct option for the image data is selected before continuing.</i>
<b>Image Type</b>	Select <b>Axial, Coronal, Sagittal, or Unknown</b> for the image type direction <i>NOTE: If <b>Unknown</b> has been automatically defined, ensure that the correct option for the image data is selected before continuing.</i>
<b>Series comment</b>	View comments entered by the scanner operator

### MR Analyze Harddisk - Image Orientation

The MR Analyze format does not include several required image orientation parameters (left-right, head-feet, anterior-posterior) in the image header. Therefore, some of the volume parameters are default values, and may also be incorrect. For this reason, you must review, correct and verify the image parameters manually (see page 43) before continuing.

Additionally, the MR Analyze data format does not support gantry tilt or angulation, **iPlan** cannot transfer this data correctly. In order to prevent incorrect image reconstruction in the planning software, MR Analyze images with gantry tilt or angulation above 0.1° should not be used.

### Available Viewing Functions

Additional viewing functions are available via the toolbar to the right of the image view (see page 67).

### Next Steps

Step
Once the settings have been selected, click <b>Yes</b> in the prompt that appears to confirm your changes. You are then branched back to the <b>Advanced Data</b> dialog.

## 2.4.6 Deleting Slices

### General Information

If you have imported DICOM data, you can delete slices from the selected image set.

### How to Delete Slices

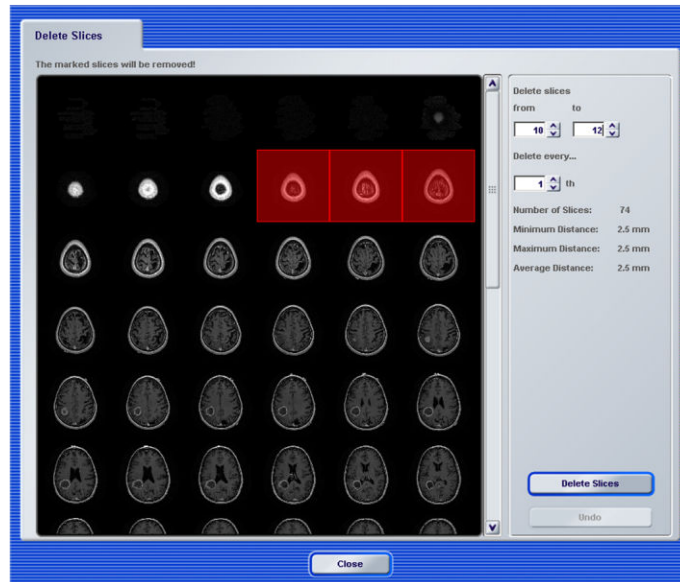

Figure 16

Steps	
1.	Click <b>Delete Slices...</b> in the <b>Functions</b> area.
2.	In <b>Delete slices from [x] to [x]</b> , specify the range of slices to be deleted. Example: Slice 1 to 10
3.	In <b>Delete every ... [x] slice</b> , define whether all slices in the defined range should be deleted or whether specific slices should be skipped. Example: If you wish to delete slices 10, 20, etc., make the following entry: <b>Delete every ... [10] slice</b>
4.	Click <b>Delete Slices</b> to confirm deletion.

*NOTE: If you have not yet exited the **Delete Slices** dialog, you can reverse the delete action using the **Undo** button.*

## 2.4.7 Sorting Images

### General Information

DICOM images are loaded individually by **iPlan**. For this reason, they must be grouped as image sets. Certain default settings cannot be modified. Standard DICOM datasets such as CT or MR are generally already correctly grouped. However, depending on the scanner settings used, the settings described below can be modified so that DICOM images can be properly grouped with the required dataset.

### How to Access Sorting

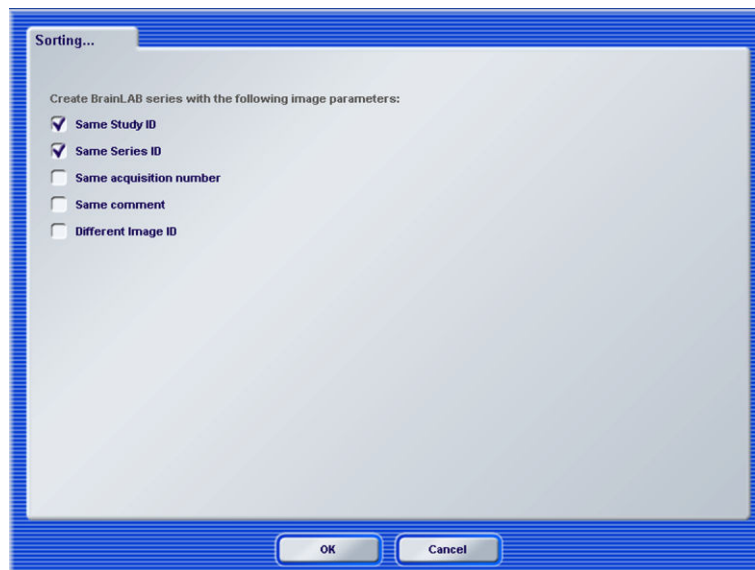

Figure 17

Steps	
1.	Highlight the image set in the <b>Advanced Data</b> dialog that is displayed once the data has been loaded.
2.	Click <b>Sorting...</b> in the options area to the right of the dialog to open the <b>Sorting...</b> dialog (shown above).

### Parameter Selection

Steps	
	Select one or more of the following sorting parameters by clicking the corresponding check boxes:
1.	<ul style="list-style-type: none"> <li>• <b>Same Study ID</b></li> <li>• <b>Same Series ID</b></li> <li>• <b>Same acquisition number</b></li> <li>• <b>Same comment</b></li> <li>• <b>Different Image ID</b></li> </ul>
2.	Click <b>OK</b> to save these parameters and return to the <b>Advanced Data</b> dialog. The images are shown sorted according to the selected parameters.



**The sorting parameters do not affect the actual order of the image slices. Each slice retains its own x, y, z position, ensuring correct placement.**

## 2.4.8 DICOM Information

### How to Display DICOM Information

Click **Dicom Info...** in the **Advanced Data** dialog (see page 39) to display the **File display** dialog. This dialog displays DICOM header information as written by the scanner.

### File display Dialog

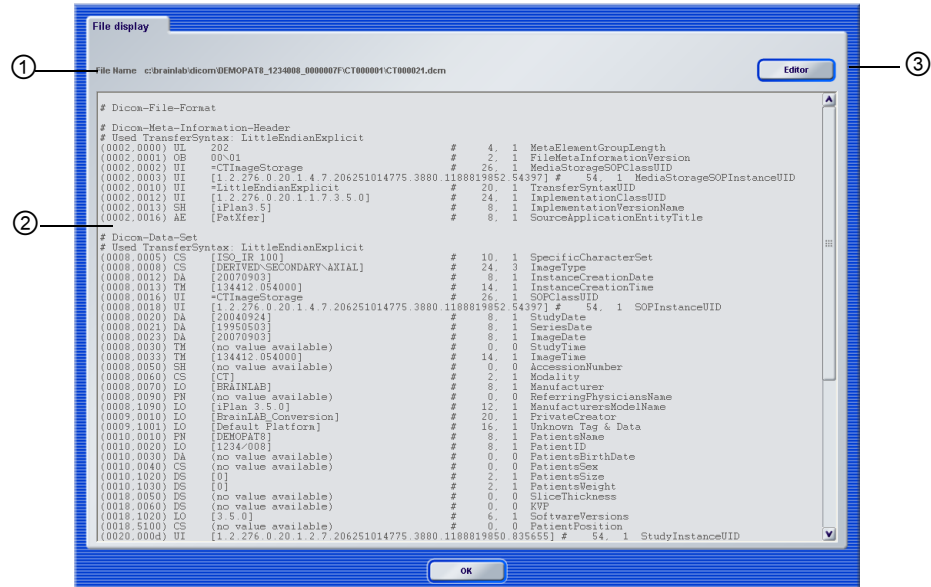

Figure 18

No.	Explanation
①	File name and file location
②	Displays the DICOM header information
③	Clicking <b>Editor</b> allows you to edit the DICOM header information, or save it to a different location. The file is shown in the <b>Notepad</b> editor where you can modify it and/or save it to your preferred location.

**NOTE:** During DICOM data import, carefully verify that all general DICOM information (e.g., modality, patient name, date of birth) has been interpreted correctly by **iPlan** and that the information sent from the scanner was correct.

## 2.5 Adding Patient Data

### Importing New DICOM Data

#### General Information

If you have already loaded patient data, and are loading new DICOM data for the patient, you have the option of merging the new data with the current patient data, or creating a separate patient file.

#### How to Add Data

After importing the data (see page 38), you are asked whether you wish to add the new data to the current patient data.

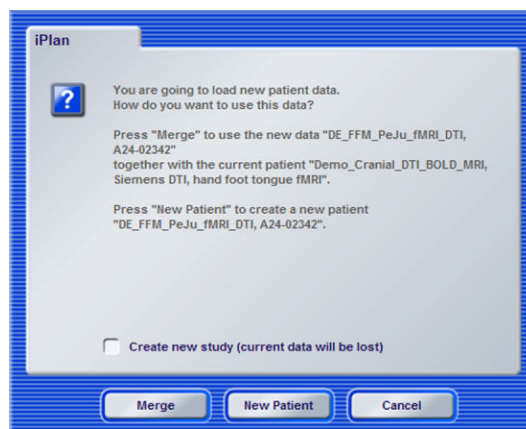

Figure 19

Options
Click <b>Merge</b> to add the new data directly to the current patient data.
Click <b>New Patient</b> to create a separate patient folder.
Select the <b>Create new study [...]</b> check box and click <b>Merge</b> to create a new study for the current patient.
Click <b>Cancel</b> to abort the import of new data.

#### Next Steps

Once data import has been completed, click **View and Adjustment** followed by **OK** in the **iPlan Navigator** (page 61) to proceed to the viewing functions.



# 3 iPLAN STEREOTAXY WORKFLOWS

## 3.1 Example Framebased Procedures

### Standard Planning Workflow

#### Background

This workflow is recommended for standard treatments that do not require time-consuming planning, for example, non-functional treatments such as biopsies, hematoma evacuations, etc. With this workflow, the patient must wear the headring throughout the entire planning procedure (beginning with image data acquisition and ending when the treatment plan is printed out).

#### Workflow

Treatment Plan Stage	Planning Step	See
Image Data	Acquire images for diagnosis and stereotactic localization	Scanning Instructions
	Load/import data and open the treatment plan	Page 23
Planning	Stereotactic localization	Page 103
	Add registration points for paired marker-based fusion	Page 137
	Fuse images	Page 147
	Outline objects	Page 163
	Plan trajectories	Page 231
	Check/modify arc settings	Page 234
Final Steps	Save treatment plan	Page 297
	Print treatment plan	Page 241
	Close <b>iPlan</b>	Page 311

### 3.1.1 Functional Planning Workflow

#### Background

This workflow is recommended for complex treatments requiring careful and time-intensive preoperative planning (for example, Electrode placement, Pallidotomy, etc.).

The workflow is divided into two parts:

1. Preoperative planning workflow: Can be performed, for example, weeks before the actual surgery
2. Planning workflow on day of surgery: For calculating arc settings in order to perform the treatment

#### Advantages

The advantage of the functional planning workflow is that the patient must wear the headring only for stereotactic localization and during the final treatment. Because the headring is not worn during the treatment planning phase, the surgeon has more flexibility and time for careful planning.

#### Preoperative Workflow

Treatment Plan Stage	Planning Step	See
Image Data (for image-based planning)	Acquire images for diagnosis	Scanning Instructions
	Load/import data and open the treatment plan	Page 23
Image-based Planning	AC/PC Localization for Schaltenbrand-Wahren brain atlas planning and AC/PC coordinate planning	Page 134
	Add registration points for paired marker-based fusion	Page 137
	Fuse images	Page 147
	Outline objects	Page 163
	Plan trajectories	Page 231
	Plan parallel tracks	Page 253
Final Steps	View depth position along track	Page 261
	Save treatment plan	Page 297
	Exit <b>iPlan</b>	Page 311

#### Workflow Day of Surgery

Treatment Plan Stage	Planning Step	See
Image Data (for registration)	Acquire images for stereotactic localization	Scanning Instructions
	Load/import data and open the treatment plan	Page 23
Registration of Patient Data	Stereotactic localization	Page 103
	Fuse images	Page 147
	Check/modify arc settings	Page 234
	Save treatment plan	Page 297

<b>Treatment Plan Stage</b>	<b>Planning Step</b>	<b>See</b>
	Print treatment plan	Page 241
Intraoperative Planning	Activate MER/S data backup	Page 263
	Enter MER/S data at depth positions along track	Page 263
	View MER/S data	Page 267
	Save treatment plan	Page 297

### 3.1.2 Postoperative Study Workflow

---

#### Background

This workflow is the recommended procedure if you would like to verify clinical results or evaluate the treatment procedure.

You can use this workflow, for example, to compare the initially planned trajectory with the actual position of the placed electrode once postoperative images have been acquired and added to the finalized treatment plan.

---

#### Workflow

Treatment Plan Stage	Planning Step	See
Image Data (for verifying clinical results)	Acquire postoperative images	Scanning Instructions
	Load the treatment plan (e.g, the plan that saved after entering MER/S data, see page 50)	Page 23
	Import DICOM images and merge them to the plan	Page 29
Planning	Fuse images	Page 147
Final Steps	Save treatment plan	Page 297
	Close <b>iPlan</b>	Page 311

## 3.2 Example Frameless Procedures

### Functional Planning Workflows

---

#### Background

This workflow is dedicated to planning functional treatments that will be performed using navigation (e.g., VectorVision) rather than by conventional stereotaxy (stereotactic arc).

The workflow is divided into two parts:

1. Preoperative planning workflow
  2. Planning workflow on the day of the surgery: Prepare the plan for use with the navigation system
- 

#### Advantage

This workflow allows the surgeon to decide after planning whether to carry out frameless or framebased treatment.

---

#### Preoperative Workflow

This workflow is identical to the framebased preoperative workflow (see page 50).

---

#### Workflow Day of Surgery

Treatment Plan Stage	Planning Step	See
Image Data (for registration)	Acquire images for patient registration	Scanning Instructions
	Load/import data and open the treatment plan	Page 23
Registration of Patient Data	Add registration points for paired marker-based fusion	Page 137
	Fuse images	Page 147
Final Steps	Save treatment plan	Page 297
	Export treatment plan for use with a Brainlab navigation software	Page 303
	Close <b>iPlan</b>	Page 311



# 4 APPLICATION OVERVIEW

## 4.1 Introduction to iPlan

### Overview

#### System Performance

The performance of **iPlan** is dependent upon the operating system and the computer platform. In order to optimize the performance of the software, avoid running unnecessary applications parallel to **iPlan**.

#### Additional iPlan Modules

Multiple **iPlan** modules are available, e.g., for ENT applications. If you have purchased more than one module, ensure that you have started the correct module by checking the product logo at the bottom right of the screen.

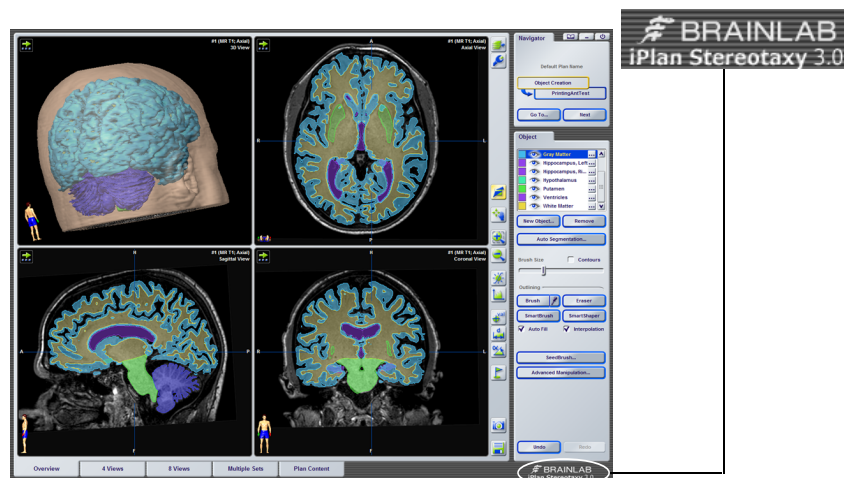

Figure 20

A separate **Software User Guide** is available for each **iPlan** module. Contact Brainlab support for more information.

## 4.1.1 Image Data and Abbreviations

---

### Compatible Image Types

The following image types can be transferred to **iPlan**:

- CT (with/without contrast agent)
- MR (with/without contrast agent)
- MR diffusion weighted images (DTI)
- BOLD MRI data (functional imaging)
- Nuclear medicine data (PET, SPECT)

*NOTE: Detailed scanning instructions are available from Brainlab support on request.*

---

### Image Quality



**Image data acquired for accurate stereotactic localization should never be a compromise between tissue distinction, spatial accuracy and localizer rod representation. This could lead to incorrect treatment planning results and harm the patient!**



**MR distortion may be intrinsic to the scanner and to the susceptibility of materials within the image volume. Therefore, the use of MR for stereotaxy by itself is not recommended, especially in the case of sagittal and coronal scanning orientations. Stereotaxy should only be performed using CT or other imaging techniques that offer high dimensional accuracy.**

*NOTE: Fusing CT and MR image sets combines the advantages of CT spatial accuracy with the superior tissue definition of MR. In this way, **iPlan** image fusion improves the accuracy by using certain types of scans for stereotaxy.*

*NOTE: **iPlan** significantly optimizes the clinical workflow as it is possible to create accurate treatment plans based on diagnostic images without including a stereotactically localized image set in the plan. The treatment plan can be finalized by simply adding and processing a stereotactically localized image set just before surgery (see the workflow alternatives).*

---

### Verifying Image Data



**iPlan provides functionality for measuring and/or calculating distances, volumes, diameters, angles, point locations (in Cartesian coordinates), etc., based on image data. To avoid patient injury due to such measurements and calculations, the user must verify the used image data to ensure that it is suitable for these purposes.**

The suitability of image data must be established, maintained and regularly verified by both the user of the image data and the image provider (e.g., the hospital's radiologist) according to the following guidelines:

- The user of the image data (e.g., **iPlan** user), as well as image provider must be aware that the provided image data is to be used by **iPlan** for geometrical measurements and calculations.
- The user of the image data is responsible for specifying image data requirements that are relevant for the specific use case (e.g., spatial accuracy) to the image provider.
- The image provider is responsible for providing image data that fulfills the requirements (e.g., spatial accuracy) specified by the user of the image data.
- The image provider is responsible for verifying that the provided image data fulfills the requirements (e.g., by calibrating the scanner and performing phantom tests using **iPlan** functionality for measuring on a regular basis).
- The user of the image data and the image provider must be aware that neither Brainlab nor the software itself can validate or verify patient specific image data that is used in combination with **iPlan** for specific use cases.



## Scan Protocols



**Stereotactic localization might fail if the scanning mode is not set in accordance with the scanning instructions. Refer to the corresponding scan protocol provided by Brainlab for the correct scanning instructions.**

## 4.2 User Interface

### Main Screen

#### General Information

The main screen is displayed after selecting a planning task from the **Navigator** area (see page 60) or the **iPlan Navigator** (see page 61).

#### Screen Layout

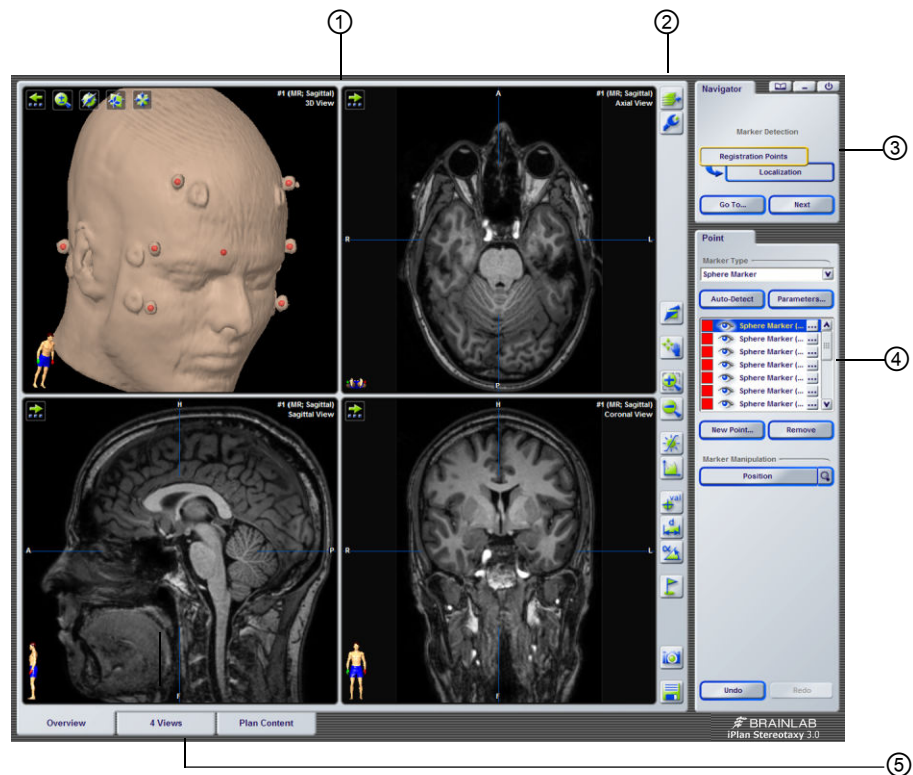

Figure 21

No.	Explanation	See
①	Planning area displaying image views	Page 65
②	Toolbar functions	Page 67
③	Navigator area	Page 60
④	Functions area	Page 61
⑤	Tab pages to select display options for each planning task	Page 64

## 4.2.1 Overview of Dialogs

### General Information

When certain functions are opened, a separate dialog opens where you can define various settings.

### Screen Layout (Example)

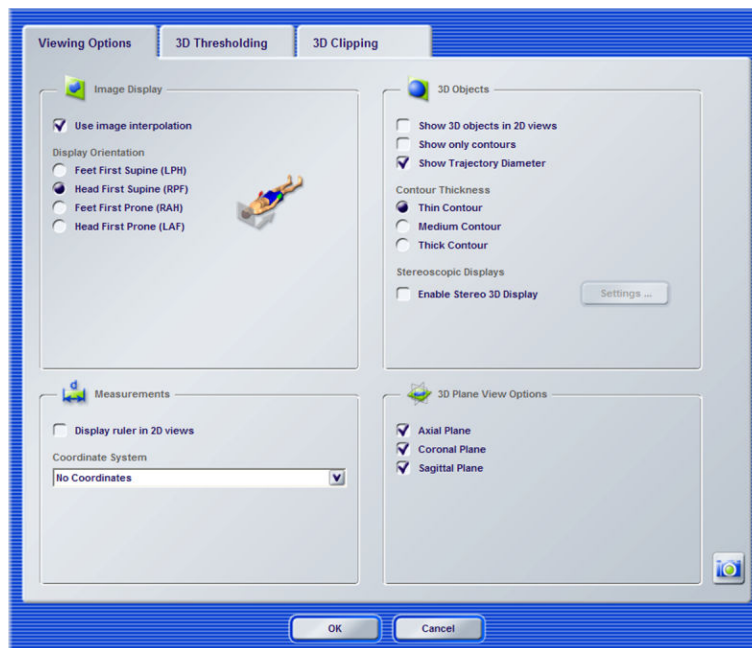

Figure 22

### General Functions

Function	Explanation
OK	Saves your changes and closes the dialog
Cancel	Closes the dialog without saving your changes

## 4.2.2 The Navigator Area

### Layout

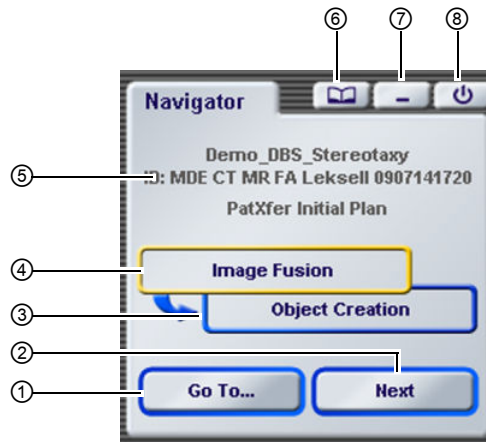





Figure 23

No.	Explanation
①	Opens the <b>iPlan Navigator</b> so that you can select planning tasks in any order (see page 61)
②	Opens the next planning task
③	Next planning task (outlined in blue)
④	Current planning task (outlined in yellow)
⑤	Patient name, ID and treatment plan name
⑥	 Opens a PDF of the <b>iPlan</b> software user guide
⑦	 Minimizes the <b>iPlan</b> window so that it is only open in the background
⑧	 Shuts down the <b>iPlan</b> software (see page 311)

### How to Select a Planning Task

Options
To go to the next planning task, click <b>Next</b> .
To open the <b>iPlan Navigator</b> to select another planning task, click <b>Go To...</b>

### 4.2.3 The iPlan Navigator

#### Layout

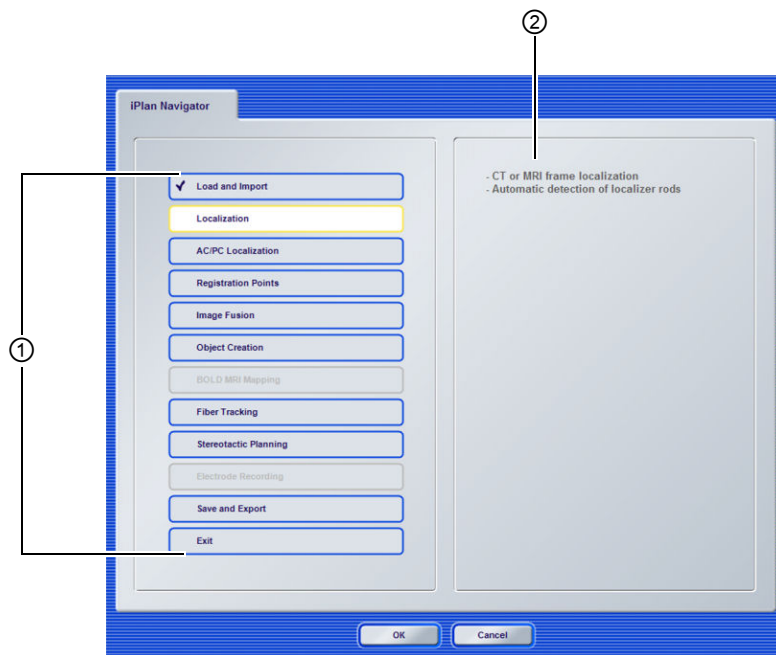

Figure 24

No.	Explanation
①	<input checked="" type="checkbox"/> Available planning tasks Completed planning tasks are indicated by a check mark
②	Description of the selected planning task

*NOTE: A grayed out planning task indicates that the task is not available, either because it is not applicable for the loaded data, or because the feature is not included in your license.*

#### How to Select a Planning Task

Options
To open a planning task, select the task, and click <b>OK</b> , or double-click the task.
To exit the <b>iPlan Navigator</b> without selecting a task, click <b>Cancel</b> . The software returns you to the previous screen.

## 4.2.4 The Functions Area

### General Information





Figure 25

The functions specific to each planning task are available in the functions area. The example below shows the functions area for the **Registration Points** planning task.

### Visibility of Planned Content

The eye symbol next to each list entry indicates whether the planned content (e.g., a registration point or created object) is visible in the image views.

Options	
	This icon appears once you add an item to the list. It indicates you have not yet added the planned content to the image views (e.g., by positioning a registration point in the image).
	Once you have added the planned content to the image views, an open eye icon means the planned content is visible. Click the eye symbol to hide the content.
	A closed eye icon means the planned content is hidden. Click the eye symbol to show the planned content again.

## Adjusting the Properties and Color of Planned Content

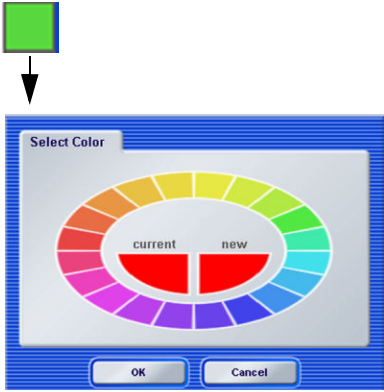
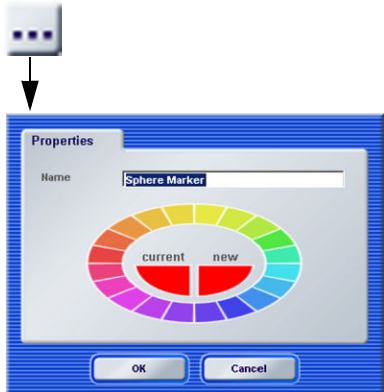
Options	
	<p>Clicking a color icon next to a list entry opens the <b>Select Color</b> dialog in which you can select a color for the planned content.</p> <p>Select a color from the palette and click <b>OK</b> to confirm.</p>
	<p>Clicking the properties icon next to a list entry opens the <b>Properties</b> dialog in which you can modify the name/color of the planned content.</p> <p>Define a name and select a color from the palette.</p> <p>Click <b>OK</b> to confirm your selections.</p> <p><i>NOTE: Additional settings that are available for a particular planning task are described in the corresponding chapter.</i></p> <p><i>NOTE: If <b>Advanced 3D</b> is activated, some objects might be displayed in a special color (see page 93).</i></p>

## General Functions

Depending on the selected planning task, the following general functions may be available in the functions area:

Function	Explanation
Undo/Redo	Undo or redo any modifications you have made in a planning task
Progress bar	Provided for certain operations (e.g., opening a treatment plan). These operations can be terminated by clicking Cancel (displayed under the progress bar).

*NOTE: Planning task specific functions are described with the corresponding planning task.*

## 4.2.5 Tab Pages

---

### General Information

The tab pages allow you to select viewing options for the planning area. Tab page selection varies depending on the planning task you are in.

---

### Available Tab Pages



Figure 26

The following tab pages are available in multiple planning tasks:

- **Overview** (page 82)
- **4 Views, 8 Views, and 9 Views** (page 84)
- **X-ray Images** (page 86)
- **Multiple Sets** (page 87)
- **Plan Content** (page 88)

*NOTE: Other tab pages that are specific to a planning task are described with the corresponding task.*



## 4.2.6 Image Views in the Planning Area

### General Information

The images contained in the treatment plan are displayed in different views in the planning area. You can perform most of the planning functions directly in the image views.

### Planning Area Layout

Depending on the selected planning task and view tab, the following image displays are possible:

- 3D view
- Slice views (axial, sagittal or coronal)
- Reconstructions or oblique reconstructed images

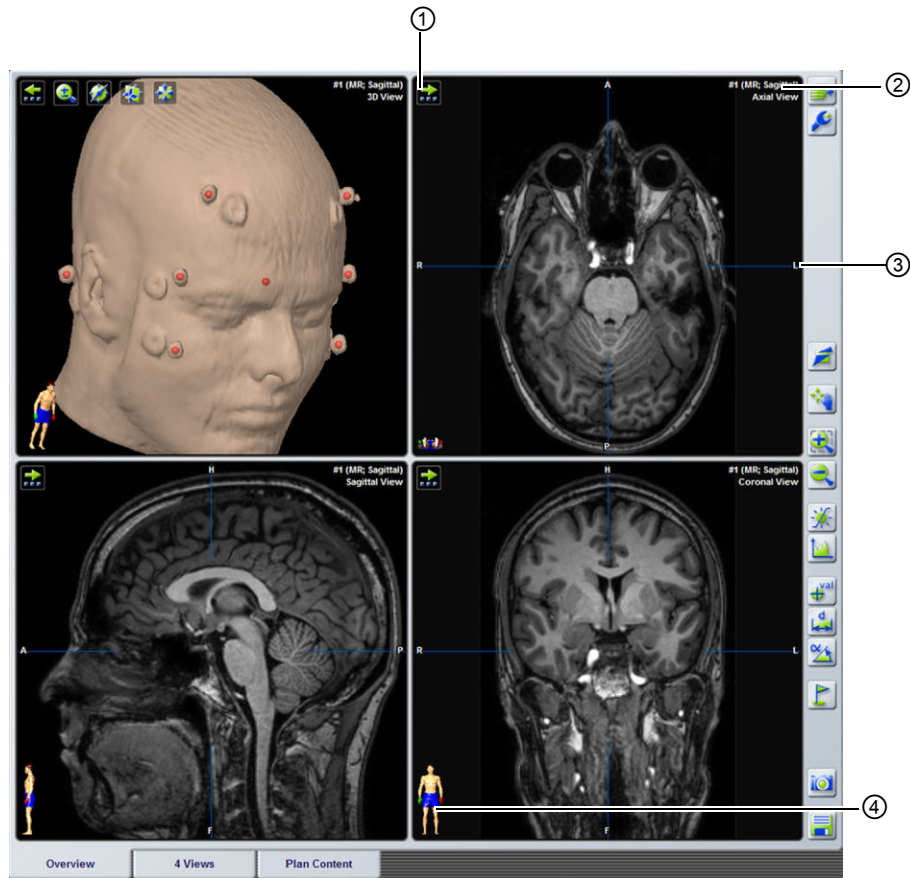

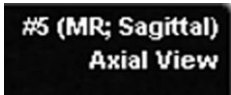

Figure 27

### Planning Area Explanation

No.	Explanation
①	 <p>Arrow button: Provides access to view configuration options (see page 73).</p>
②	 <p>Reconstruction views show images that have been reconstructed from original image slices. The following information is displayed in reconstruction views:</p>

No.	Explanation
	<ul style="list-style-type: none"> <li>• The orientation indicated in the first line in brackets is the orientation at which the image set was initially acquired.</li> <li>• The orientation indicated in the second line is the reconstructed view of the image.</li> <li>• The type of scan (e.g., MR or CT) and the number identifying the scan set (e.g., #1) are also indicated.</li> </ul> <div style="border: 1px solid black; padding: 2px; margin: 5px 0;"> <p><b>#5 (MR; Sagittal)</b> <b>Original 129/256</b></p> </div> <p>Original slice views show image slices as they were originally acquired (axial, coronal or sagittal). In views showing original image slices, the following information is displayed:</p> <ul style="list-style-type: none"> <li>• The first line indicates the scan type (e.g., MR or CT), the number identifying the scan set (e.g., #1) and the scan orientation.</li> <li>• The second line indicates the number of the current slice in the scan set.</li> </ul> <div style="border: 1px solid black; padding: 2px; margin: 5px 0;"> <p><b>#5 (MR; Sagittal)</b> <b>Sagittal Custom 128/256</b></p> </div> <p>A custom orientation indicates that, e.g., then image set has been AC/PC localized.</p> <p><i>NOTE: Custom orientation is not available for 2D views that show the original slice orientation.</i></p> <p><i>NOTE: Custom orientations are only displayed in <b>iPlan</b> and in the Brainlab navigation software.</i></p>
③	<p>Letters at the outer edge of the views indicate the orientation of the image:</p> <ul style="list-style-type: none"> <li>• A (anterior), P (posterior)</li> <li>• L (left), R (right)</li> <li>• H (head), F (feet)</li> </ul>
④	<p>Patient icon indicating the orientation of the displayed images.</p>



## 4.2.7 Toolbar and Function Buttons

### General Information



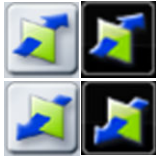

Depending on the tab page selected in the planning area, the toolbar and the image views may contain the functions listed below.



- Function buttons with a gray background are provided in the toolbar (see page 58).
- Function buttons with a black background are provided in the individual image views. Using these buttons affect only the view in which the button is selected (see page 73).

### Image Selection Buttons

Button	Explanation	See
	<b>Slice and Image Set Selection:</b> Select the scan images to be displayed in the planning views	Page 274
	<b>Browse Slice:</b> Browse single image slices in ascending or descending order	Page 283
	<b>Browse Slices:</b> Browse multiple image slices in ascending or descending order	Page 283
	<ul style="list-style-type: none"> <li>• In reconstruction views, use <b>Depth Scrolling</b> a to scroll through scan reconstructions along the axis indicated by the patient icon (shown bottom left of the image view)</li> <li>• In slice views, use <b>Slice Scrolling</b> to scroll through available slices</li> </ul>	Page 283



### Viewing Option Buttons

Button	Explanation	See
	<b>Options:</b> Access advanced viewing options	Page 275
	<b>Pan and Recenter:</b> Recenter and display vertical and horizontal planes that can be used to adjust the reconstruction planes	Page 284
	<b>Recenter View:</b> Reset the position of the 3D scene in the view if it was changed by panning.	Page 284
	<b>View Types:</b> Select the type of view to be displayed (e.g., planes, 3D or objects)	Page 77

Button	Explanation	See
	<b>View Orientation:</b> Change the view orientation	Page 76
	<b>Composing Options:</b> Verify two image slices from different image sets that have been fused	Page 79



---

### Zoom Buttons

Button	Explanation	See
	<b>Zoom In/Out:</b> Increase or decrease image magnification	Page 285
	<b>Full Screen:</b> Enlarge the current view to full screen	Page 75





---

### Windowing Buttons

Button	Explanation	See
	<b>Windowing:</b> Adjust the gray level distribution in the displayed images	Page 286
	<b>Advanced Windowing:</b> Provides advanced options for adjusting the gray value, Hounsfield or SUV distribution for the selected image	Page 287

---



### Measurement and Labeling Buttons

Button	Explanation	See
	<b>Measure Hounsfield Units:</b> Measure the Hounsfield units of up to three points in an image slice (available for CT image sets)	Page 291
	<b>Measure Values:</b> Measure the value (e.g., gray or SUV) of up to three points in an image slice (available for SPECT or PET image sets)	Page 291
	<b>Measure Distances:</b> Measure the distance between up to three point pairs in an image slice	Page 293
	<b>Measure Angles:</b> Measure the angle between three points in an image slice	Page 293

Button	Explanation	See
	<b>Add/Remove Points:</b> Add and remove points in an image set	Page 294

---

**Additional Buttons**

Button	Explanation	See
	<b>Screenshot:</b> Take screenshots of the displayed views and dialogs	Page 296
	<b>Save Treatment Plan:</b> Save changes to the current treatment plan	Page 297
	<b>Print:</b> Print the finalized treatment plan	Page 241

## 4.2.8 Mouse/Keyboard Shortcuts

### General Shortcuts

Shortcut	Action
<p>Mouse wheel</p> <p>You can also use the up/down arrows on your keyboard to scroll forward/backward by one slice.</p>	Scroll slice by slice through images
<p>Mouse wheel + SHIFT</p> <p>You can also use the <b>Pg Up /Pg Dn</b> keys on your keyboard to scroll forward/backward by three slices.</p>	Scroll in increments of three or seven slices (depending whether you are in <b>4 Views</b> or <b>8 Views</b> tab) through images
Right mouse button	In the 3D view, adjust the 3D object up, down, left, right
CTRL + left mouse button	Like the <b>Pan and Recenter</b> function (see page 284)
CTRL + mouse wheel	Zoom in and out on images (see page 285)
<p>Double-click on a point listed in the functions area</p> <p>If you double-click on a trajectory in the list, the view is centered to the target point of that trajectory.</p>	Recenter the view to a particular point, e.g., a registration point
Double-click on an object/region of interest listed in the functions area	Recenter the view to the center of the object/region of interest
<p>Double-click on a labeled point in the <b>Plan Content</b> tab (see page 88)</p> <p>When you open e.g., the <b>Overview</b> tab, the views are centered to the selected point.</p>	Recenter the view to a labeled point (see page 73)
<p>Double-click on an image set in the <b>Plan Content</b> tab (see page 88)</p> <p>When you open e.g., the <b>Overview</b> tab, the selected image set is shown in the views</p>	Select an image set to display in the views
Print Screen key	Create screenshot of current screen
CTRL + S	Save plan
CTRL + Z	Undo
CTRL + Y	Redo
CTRL + 0	Reset view (zoom and zoom center)
CTRL + P	Like the <b>Print</b> button in the toolbar (see page 241)

### Shortcuts in Planning Tasks

Planning Task	Shortcut	Action
Object Creation	Click the right mouse button on the area to be erased	Erase area created with the <b>Brush</b> (see page 168)
	Double-click in view ( <b>Band Thresholding</b> dialog, see page 177)	Focus ROI (region of interest)

Planning Task	Shortcut	Action
Image Fusion	Click left mouse button and move mouse left/right to switch between blue/amber images	Switch between amber and blue images
Registration Points Planning	ALT and click left mouse button Release ALT key and click left mouse button to adjust the position of the point.	Add new registration point
All planning tasks where <b>Add/Remove Points</b> is available (see page 294)	ALT and click left mouse button Release ALT key and click left mouse button to adjust the position of the point.	Add new labeled point





# 5 CONFIGURING VIEWS

## 5.1 Configuring Individual Views

### View Buttons

#### General Information

During planning, you can use the buttons available in the image views to configure various view options. This allows you to modify an individual view in a view tab.

#### How to Access View Buttons

<b>Step</b>	
	Click the arrow button in the upper left corner of the view. <i>NOTE: View buttons are deactivated by default.</i>

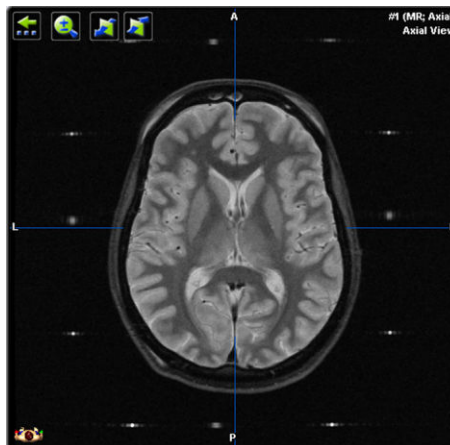











Figure 28

#### Button Availability

The available buttons vary depending on the view and the selected view tab.

	<b>View Types</b> (page 77)
	<b>View Orientation</b> (page 76)

	<b>Composing Options</b> (page 79)
	<b>Full Screen</b> (page 75)
 	<b>Browse Slice</b> (page 283)
	<b>Recenter View:</b> Resets the position of the 3D scene in the view if it was changed by panning.
	<b>Advanced Windowing</b> (page 287)
	<b>Slice and Image Set Selection</b> (page 274)

## 5.1.1 Full Screen

### General Information

The **Full Screen** button is available in every view, and allows you to display the view as a full screen.

### How to Activate Full Screen

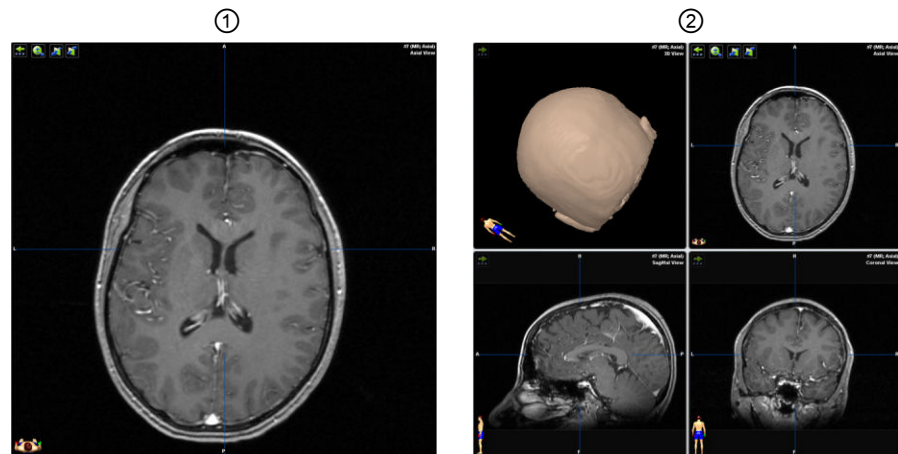



Figure 29

Steps	
1.	 Click <b>Full Screen</b> in any view to display the view as a full screen ①.
2.	Click <b>Full Screen</b> again to return the screen to the previous display ②.

## 5.1.2 View Orientation

### General Information

In certain views, the **View Orientation** button allows you to change the view orientation.

### How to Select the View Orientation

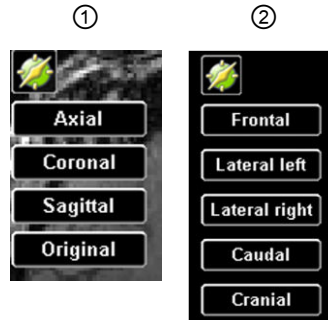



Figure 30

Steps	
1.	<div style="display: flex; align-items: center;">  <div> <p>Click <b>View Orientation</b> to display the orientation options.</p> <ul style="list-style-type: none"> <li>• Slice view options ①</li> <li>• 3D view options ②</li> </ul> <p><i>NOTE: Additional slice view options are available if you have created high resolution objects in <b>Object Planning</b> (see page 180).</i></p> </div> </div>
2.	<p>Select the orientation.</p> <p>The view is updated accordingly.</p>

### 5.1.3 View Types

#### General Information

In 3D views, the **View Type** button allows you to select the type of 3D view to be displayed (planes, 3D, objects).

Depending on the system configuration, different options for visualization are available (see page 93).

#### How to Define the View Type

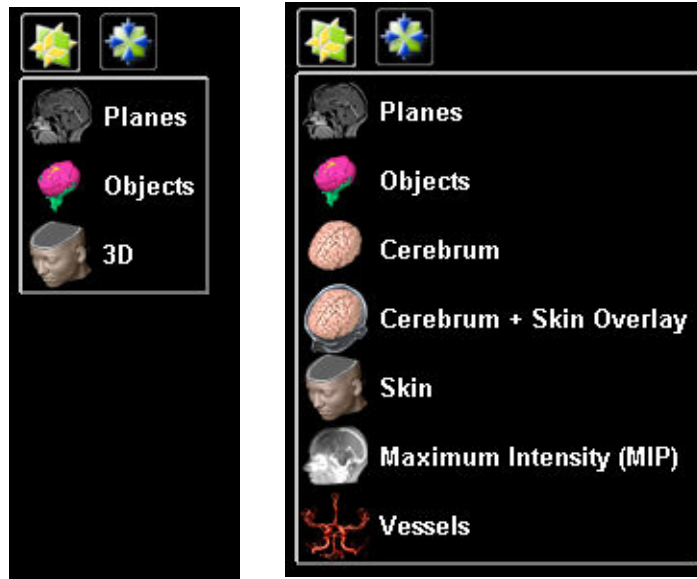

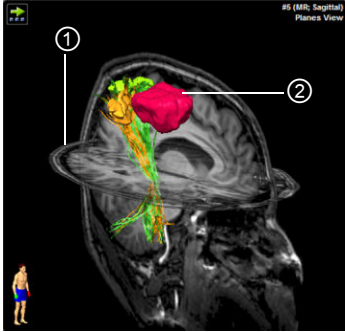
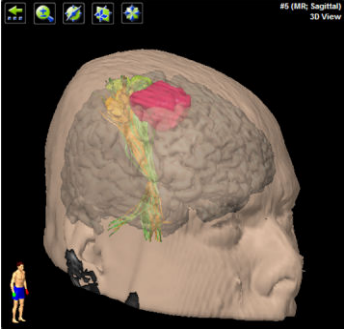



Figure 31

Steps	
1.	 Click <b>View Type</b> to display the view type options (see page 78).
2.	Select the view type. The view is updated accordingly. <i>NOTE: You can select the planes to be displayed (axial, coronal, sagittal) and whether to display 3D objects in the <b>Viewing Options</b> tab via the <b>Options</b> button (see page 275).</i>

## View Type Options

Options	
 A sagittal MR scan of a human head. The brain is shown in grayscale. Several colored regions are highlighted: a pink region in the frontal lobe, a yellow region in the temporal lobe, and a green region in the brainstem. Two white lines with circular markers labeled '1' and '2' point to these regions. A small human figure is visible in the bottom left corner.	<p>Clicking <b>Planes</b> displays segmented objects ②, and plane reconstructions ①</p> <p><i>NOTE: The position of the planes change according to any adjustments made in the 2D view.</i></p>
 A 3D view of the entire scan area. The brain is shown in a light gray, semi-transparent 3D reconstruction. The segmented objects (pink, yellow, green) are visible within the brain. A small human figure is visible in the bottom left corner.	<p>Clicking <b>3D</b> displays a three-dimensional view of the entire scan area including all planned objects</p>
 A 3D view of all planned objects. The brain is shown in a dark gray, semi-transparent 3D reconstruction. The segmented objects (pink, yellow, green) are visible within the brain. A small human figure is visible in the bottom left corner.	<p>Clicking <b>Objects</b> displays a three-dimensional view of all planned objects</p>

*NOTE: For more advanced 3D viewing options see page 93.*

## 5.1.4 Composing Options

### General Information

The **Composing Options** button allows you to verify two image slices from different data sets that have been fused.

*NOTE: This button is available only in the upper left view and lower views of the **Multiple Sets** tab (where corresponding image slices from different data sets are displayed).*

### How to Select Composing Options



Figure 32

Steps	
1.	 Click <b>Composing Options</b> to display the available options.
2.	Select the composing option. The view is updated accordingly. <i>NOTE: Composing options are described from page 79.</i>

### The Spy Glass Option

Click **Spyglass** to compare a defined area of the reference (slice from upper right view) to the slice in the current image view.

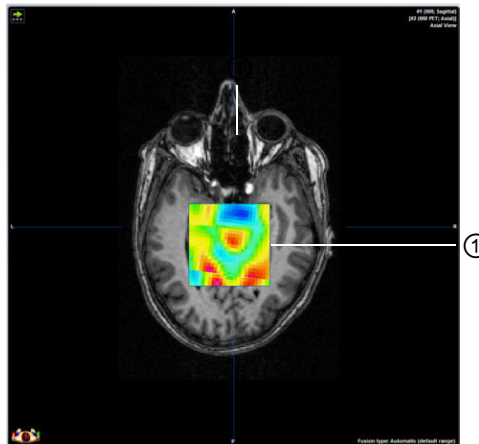

Figure 33

Options
Position the frame ① over the relevant area and verify the reference and current image slices by comparing the area inside of and at the frame edges.

<b>Options</b>
To resize the frame, use the mouse pointer to click-drag the edge of the frame.

**The Amber/Blue Option**

Click **Amber/Blue** to compare details in the entire reference image slice (slice from the upper right view) to the slice in the current image view. The reference image slice (amber) and image slice in the view where you made the selection (blue) are shown overlaid.

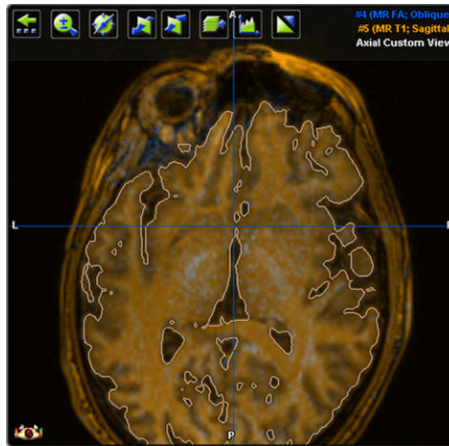

Figure 34

<b>Options</b>
Place your mouse pointer over the image and drag the mouse to the right to display more information on the reference image slice.
Drag the mouse to the left to display more information for the current image slice.

**The Overlay Option**

Click **Overlay** to overlay two different image sets on top of each other. You can overlay different image modalities to see functional data displayed with anatomical data (e.g., T1 images and PET). When you select this option, the image slice in the view where you made the selection is overlaid onto the reference image slice (slice from the upper right view).

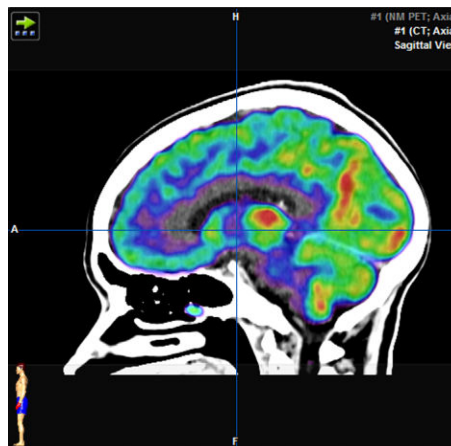

Figure 35



Options
Place your mouse pointer over the image and drag the mouse to the right to display more information on the image slice in the current view.
Drag the mouse to the left to display more information for the reference image slice.

*NOTE: The reference image slice is always shown with the same intensity, while the image slice in the selected view fades from left (invisible) to right (full intensity).*

---

### Deactivating Composing Options

Clicking **Off** deactivates the **Composing Options**.

## 5.2 Image View Tabs

### Overview Tab

#### Screen Layout

The **Overview** tab displays an overview of the selected image set.

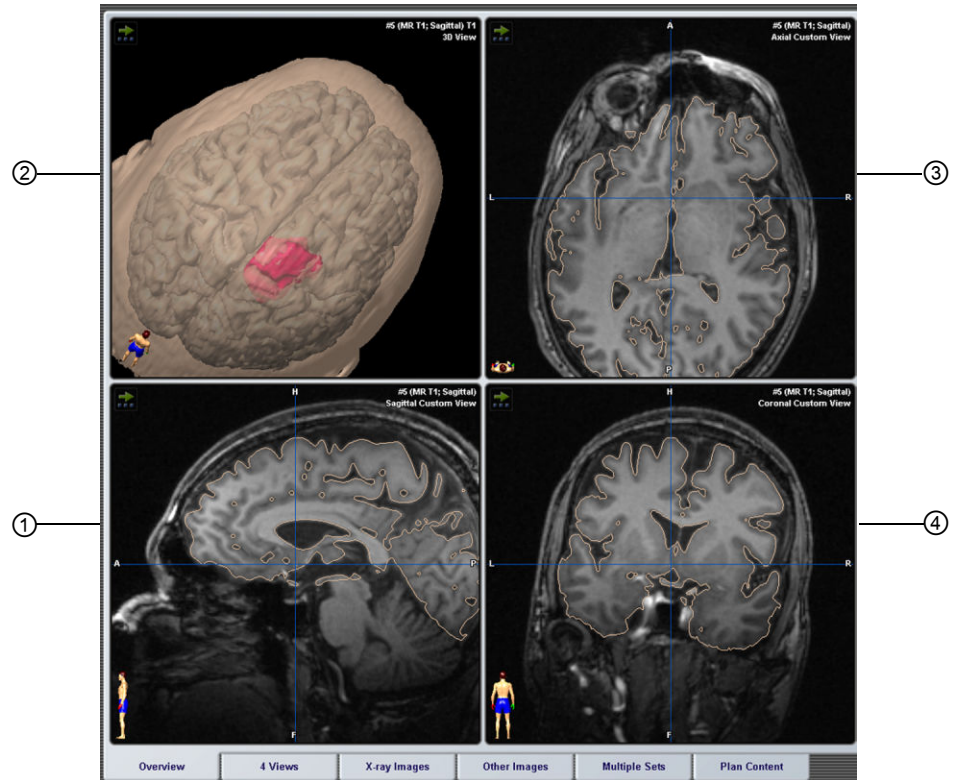

Figure 36

No.	Explanation
①	Sagittal view of the selected slice
②	3D view based on the selected treatment plan
③	Axial view of the selected slice
④	Coronal view of the selected slice

#### How to Position the 3D Shape

You can rotate or adjust the three-dimensional model in the 3D view in order to see it from different perspectives. The options depend on the position of the mouse pointer in the view.

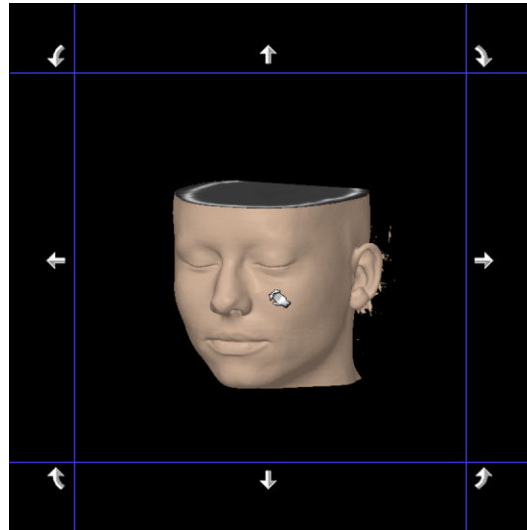

Figure 37

Mouse Pointer Position	Rotation Option
Center of the view	Use the hand with a curved arrow to rotate the three-dimensional model in any direction
Left, right, top or bottom of the view	The arrow indicates the direction in which you can move the three-dimensional model
Corners of the view	The angled arrow indicates the direction you can tilt the model (left or right)

*NOTE: You can adjust the orientation and the type of 3D image to be displayed using the **View Options** and **View Types** buttons.*

### Showing a Bone Surface

If you enable the **Bone in 3D** check box in the functions area (or select view type **Bone/Vessels** for an advanced 3D view), bone surface based on the CT images is displayed in the 3D view ①. When disabled, a standard 3D model (with soft tissue) is displayed ②.

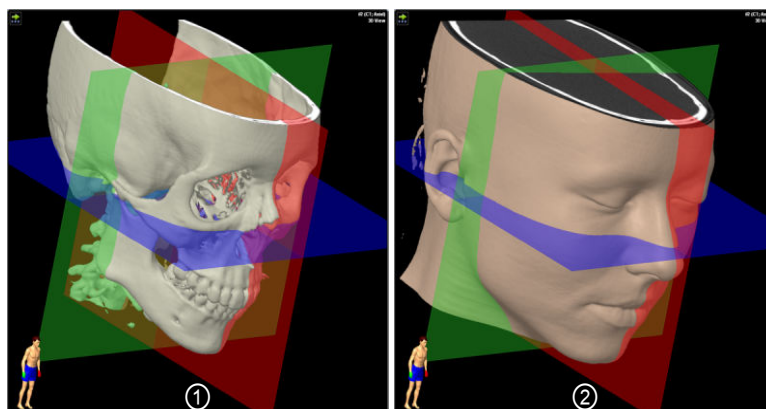

Figure 38

*NOTE: This option is available only if CT images are selected.*

## 5.2.1 Slice View Tabs

### Screen Layout

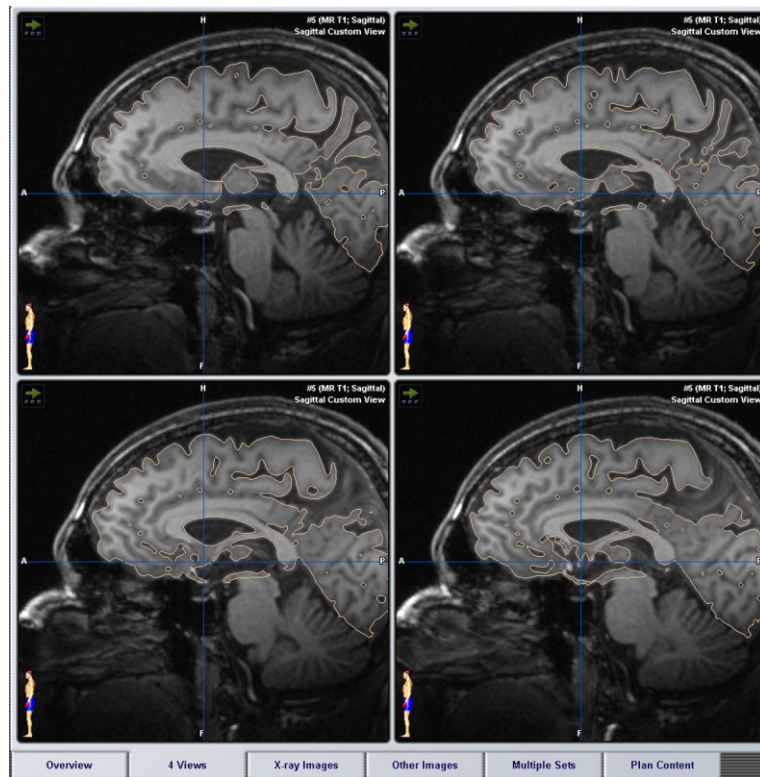

Figure 39

Slice view tabs display consecutive slices in the axial, coronal or sagittal views from the selected image set. The example below shows the **4 Views** tab.

Viewing 8 and 9 Consecutive Slices

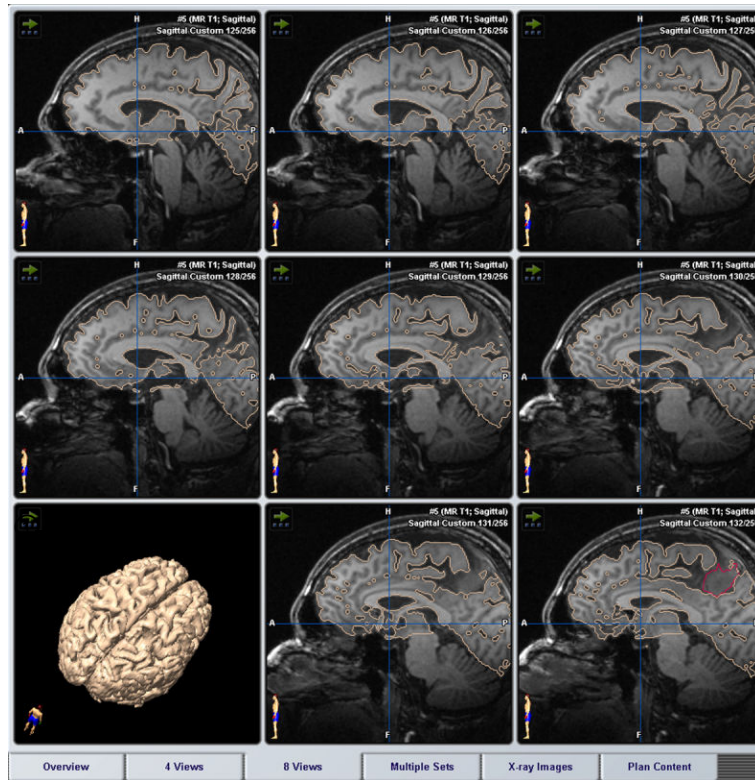

Figure 40

The **8 Views** and **9 Views** tabs are available in some planning tasks. Here, you can view objects you have created in eight or nine consecutive image slices. In the **8 Views** tab, you can also display a 3D view of the object by clicking directly in the lower left view. The shape can be rotated freely around every axis (see page 82).

## 5.2.2 X-ray Images Tab

### Screen Layout

If the patient data you have loaded includes X-ray image data, this is displayed in a separate **X-ray Images** tab.



Figure 41

No.	Explanation
①	The first line indicates the image type and the number identifying the image (e.g., #1).
②	The second line indicates the number of the current image in the image set

*NOTE: Standard X-ray and DSA X-ray images are supported.*

### 5.2.3 Multiple Sets Tab

#### General Information

The **Multiple Sets** tab displays multiple image sets that have been fused, allowing you to view planned content in different image sets simultaneously.

*NOTE: In the **View and Adjustment** planning task, you can also view multiple image sets, even if they have not been fused. In other planning tasks, e.g., **Object Creation**, the image sets must first be fused before you can view multiple sets.*

#### Screen Layout

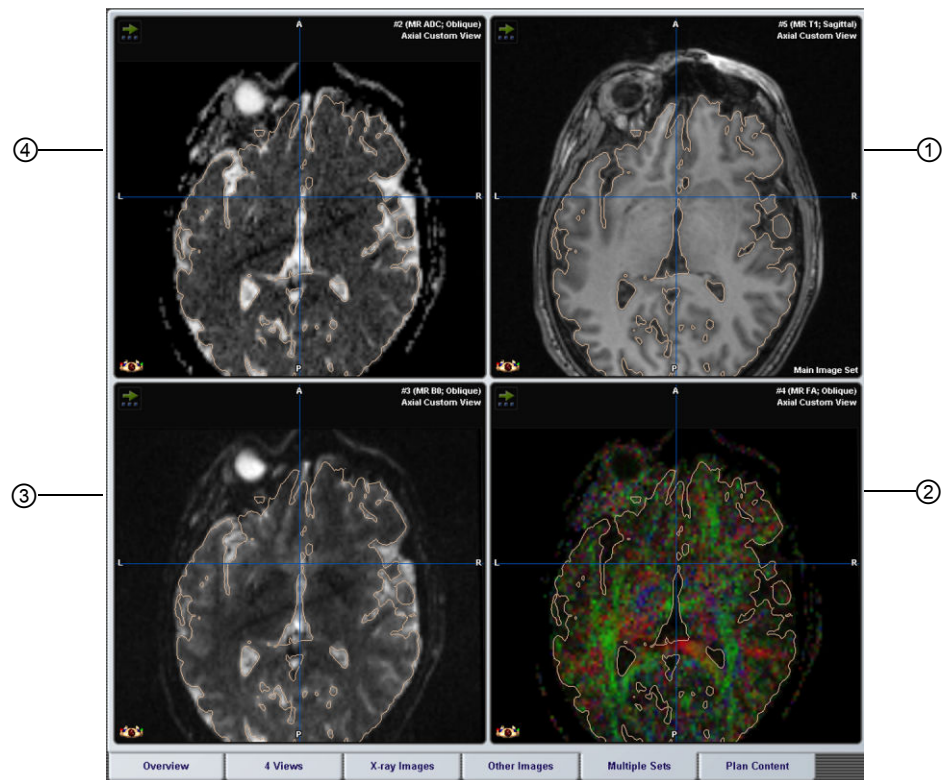

Figure 42

No.	Explanation
①	Displays the slice from the current image set This is the reference image slice for the slices displayed in the other image views. The other views display slices from image sets fused to the first set
②	Displays overlays of the reference image set ① or of other available image sets that can be selected using <b>Slice and Image Set Selection</b> (see page 274)
③	If you adjust the position of the image slice in any of the views using e.g., the <b>Pan and Recenter</b> function, the slices in the other views adjust accordingly
④	

## 5.3 Plan Content Tab

### Overview

#### Screen Layout

The **Plan Content** tab displays a data tree showing image sets and planned content (e.g., 3D objects, labeled points, trajectories, etc.) that are included in your treatment plan.

To expand a section of the data tree in order to view the patient data it contains, click the corresponding '+' icon.

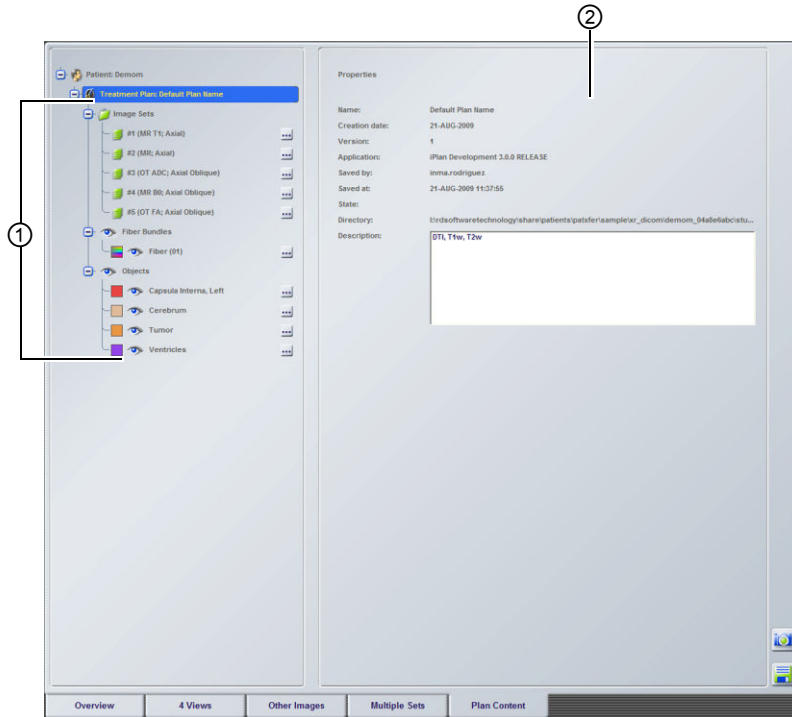

Figure 43

No.	Explanation
①	Displays folders (in a directory structure) that contain all planned content included in the treatment plan (see page 91). Folders (also displayed) that contain all image sets included in the treatment plan (see page 89).
②	The <b>Properties</b> section displays information on the image set or planned content that is selected in ①.



### 5.3.1 Image Sets

#### How to View and Select Image Sets

In the **Plan Content** tab, you can review the properties of image sets and select an image set to be displayed in any planning task.

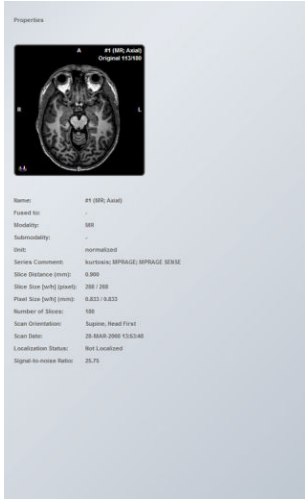
Steps	
1.	 Click the icon next to the <b>Image sets</b> folder to display the available image sets.
2.	<div style="display: flex; align-items: flex-start;"> <div style="flex: 1;">  </div> <div style="flex: 2; padding-left: 20px;"> <p>Click the required image set to select it. The following information is displayed in the <b>Properties</b> section:</p> <ul style="list-style-type: none"> <li>• An image set preview that you can scroll through to view image slices</li> <li>• Information on the selected image set e.g., other images sets that it is fused to, image set modality, submodality, etc.</li> <li>• <b>Signal-to-noise Ratio:</b> A well-known parameter for image quality. You can use the displayed value as criteria for selecting image sets that are suitable, e.g., for object segmentation. The higher the number, the better the image quality.</li> </ul> </div> </div>

#### Image Set Submodality

In the **Plan Content** tab, you can define the submodality of the scan image. The navigation software will configure three-dimensional views according to the image modality.

The following submodalities are available:

- CT: Angio
- MR: Angio, T1, T2, T1 contrast, Functional, FA (DTI Fractional Anisotropy), ADC (DTI Apparent Diffusion Coefficient), BOLD (Blood Oxygen Level Dependent MR)
- Nuclear Medicine: PET, SPECT



**The volume of objects presented at the right side of the Plan Content tab depends on the used algorithm and can differ from the expected value.**

#### How to Define the Submodality



Figure 44

<b>Steps</b>	
1.	 Click the properties icon next to the desired image set to open the <b>Properties</b> dialog.
2.	Select the image set submodality from the drop down list in the <b>Submodality</b> field.
3.	Click <b>OK</b> to apply your settings and close the dialog.

## 5.3.2 Planned Content

### How to View Planned Content Properties

In the **Plan Content** tab, you can review the properties of all planned content contained in the plan (e.g., objects, registration points, etc.).

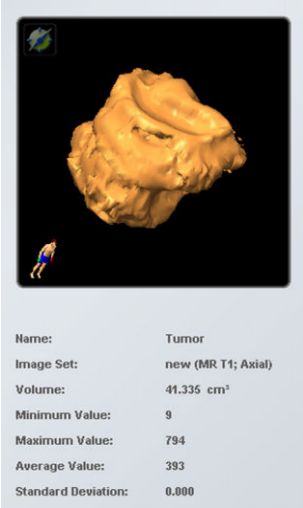

Steps	
1.	 Click the icon next to a planned content folder e.g., <b>Objects</b> .
2.	<div style="display: flex; align-items: center;">  <div> <p>Click the required item in the list to select it. Depending on your selection, various information is displayed in the <b>Properties</b> section, e.g.:</p> <ul style="list-style-type: none"> <li>• A 3D preview of the item</li> <li>• The image set in which the object is created</li> </ul> </div> </div>

### Copy to Clipboard

In some planning tasks, a **Copy to Clipboard** button is shown in the **Plan Content** tab beneath the properties information. This function allows details on an object or ROI volume to be copied to the Windows clipboard, e.g., for transfer to an external file.

### How to Adjust the Visibility of Planned Content

The eye symbol next to each list entry in the data tree indicates whether the planned content is visible in the image views.

Options	
	An open eye icon means the planned content is visible. Click the eye symbol to hide the content
	A closed eye icon means the planned content is hidden. Click the eye symbol to show the planned content
	If the data tree contains activated and deactivated items, a half-closed eye icon is shown at the top of the data tree

### How to Adjust the Color and Properties of Planned Content

You can view and modify the properties of planned content at in the **Plan Content** tab.

Options	
	Clicking a color icon next to a list entry opens the <b>Select color</b> dialog in which you can select a color for the planned content (see page 63).

**Options**



Clicking the properties icon next to a list entry opens the **Properties** dialog in which you can modify the name of the planned content (see page 63).

# 6 ADVANCED 3D FEATURES

## 6.1 Introduction

### Overview

---

#### General Information

The **Advanced 3D** features provide a functional extension to the **Standard 3D** as described on page 77. You can now choose various new 3D view types (e.g., Cerebrum, Maximum Intensity Projection, and Digital Radiography) offered in the 3D view type menu. When changing the threshold, the change can be immediately viewed in 3D.

*NOTE: The availability of the **Advanced 3D** function depends on the license activated. On the **iPlan NET** server, this functionality is only available when running an "Advanced 3D Session." The **Standard 3D** function is available even if **Advanced 3D** function is not licenced or available.*

## 6.2 Advanced 3D Viewing

### View Types

#### General Information

	Select the <b>View Types</b> menu within the <b>3D View</b> . For more viewing options see page 77.
---	---

#### About View Types

**Advanced 3D** viewing offers additional 3D view types depending on the modality of the currently selected data set. The 3D view types can be chosen from a drop down menu within the 3D viewing window. The name for each view type is located next to the icon. You can easily switch between each of these viewing options.

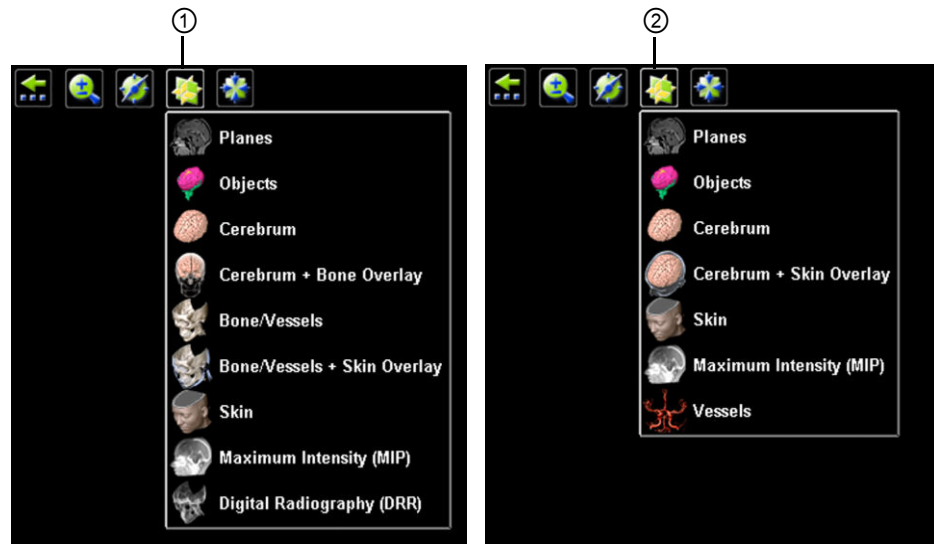





Figure 45







No.	View Type Options
①	CT image sets
②	MR image sets

Advanced 3D View Type Options

Icon	View Type	Explanation
	<p><b>Planes</b></p>	<ul style="list-style-type: none"> <li>• Displays plane reconstructions using the axial, coronal, and sagittal views from an image set.</li> <li>• Planes can be switched on and off in the <b>Viewing Options</b> dialog on (see page 276).</li> <li>• Accessible with CT, MR, PET, and other modality image sets.</li> <li>• <b>Bone</b> and <b>Skin</b> thresholding is available for this view type.</li> <li>• <b>Clipping Range</b> and <b>Cubic Cut</b> are not available with this view type.</li> </ul> <p><i>NOTE: The positioning of the planes change according to any adjustments made in the 2D view (e.g., view center of the axial, coronal, and sagittal views).</i></p>
	<p><b>Object</b></p>	<ul style="list-style-type: none"> <li>• Displays a three-dimensional view of all planned objects.</li> <li>• When <b>Cerebrum</b> was segmented (structure type "Cerebrum") it will be displayed like any other object in this view type. Transparency can be controlled via slider in the <b>Properties</b> dialog.</li> <li>• Accessible with CT, MR, PET, and other modality image sets.</li> <li>• Thresholding is not available with this view type.</li> <li>• <b>Clipping Range</b> and <b>Cubic Cut</b> are not available with this view type.</li> </ul>
	<p><b>Cerebrum</b></p>	<ul style="list-style-type: none"> <li>• Displays an advanced 3D visualization of the cerebrum within the 3D view. This is available when the <b>Cerebrum</b> object has been created (e.g., using the autosegmentation feature when available).</li> <li>• Accessible with CT, MR, PET, and other modality image sets. The selected image set must contain or be fused to a set containing a segmented cerebrum, otherwise the view type will not be offered for the selected image set.</li> <li>• Thresholding is not available with this view type.</li> <li>• <b>Cubic Cut</b> and <b>Clipping Range</b> are available for this view type.</li> <li>• For more information on the creation of the <b>Advanced 3D Cerebrum</b> Object refer to auto-segmentation when available:             <ul style="list-style-type: none"> <li>- Create a <b>New Object</b> by selecting <b>Cerebrum</b> as a <b>Structure Type</b> within the <b>Single Object/Multiple Objects</b> tab.</li> <li>- No color selection options as well as transparency settings are available for the advanced <b>Cerebrum</b>. The selected color of the cerebrum will only be displayed if the view type <b>Objects</b> is used.</li> </ul> </li> <li>• You may want to view the created cerebrum as a standard object using view type <b>Objects</b> (switch the <b>Advanced 3D Cerebrum</b> object off) if the <b>Cerebrum</b> is not detailed or insufficient due to:             <ul style="list-style-type: none"> <li>- Display artifacts (e.g., 3D rendering artifacts such as brown spots)</li> <li>- Data constraints (e.g., low resolution or contrast)</li> <li>- Segmentation inaccuracies.</li> </ul> </li> </ul>

Icon	View Type	Explanation
	<b>Cerebrum + Bone Overlay</b>	<ul style="list-style-type: none"> <li>• Displays the special cerebrum with a silhouette bone structured view surrounding it.</li> <li>• Accessible with a CT image set.</li> <li>• Thresholding is not available with this view type.</li> <li>• <b>Cubic Cut</b> and <b>Clipping Range</b> are available for this view type.</li> </ul> <p><i>NOTE: Silhouetted bone overlay remains intact when <b>Clipping Range</b> and <b>Cubic Cut</b> are applied.</i></p>

## Advanced 3D View Types Options Continued

Icon	View Type	Explanation
	<b>Cerebrum + Skin Overlay</b>	<ul style="list-style-type: none"> <li>• Displays the special cerebrum with a silhouette skin structured view surrounding it.</li> <li>• Accessible with a MR image set.</li> <li>• Thresholding is not available with this view type.</li> <li>• <b>Cubic Cut</b> and <b>Clipping Range</b> are available for this view type.</li> </ul> <p><i>NOTE: Silhouetted Skin overlay remains intact when <b>Clipping Range</b> and <b>Cubic Cut</b> are applied.</i></p>
	<b>Bone/ Vessels</b>	<ul style="list-style-type: none"> <li>• Allows the viewing of vessels and bone structure in 3D.</li> <li>• Accessible with a CT image set.</li> <li>• <b>Bone</b> thresholding as well as <b>Vessels Highlighting</b> are available for this view type.</li> <li>• <b>Cubic Cut</b> and <b>Clipping Range</b> are available for this view type.</li> </ul> <p><i>NOTE: Vessel structures may appear insufficiently when not using CT Angio or CT Contrast data. If so, turn the <b>Vessel Highlighting</b> threshold to 0% so vessels are not highlighted</i></p>
	<b>Bone/ Vessels + Skin Overlay</b>	<ul style="list-style-type: none"> <li>• Provides a silhouette of bone and skin within the 3D view.</li> <li>• Accessible with a CT image set.</li> <li>• <b>Bone</b> and <b>Skin</b> thresholding as well as <b>Vessels Highlighting</b> are available with this view type.</li> <li>• <b>Clipping Range</b> or <b>Cubic Cut</b> are available for this view type.</li> </ul>
	<b>Skin</b>	<ul style="list-style-type: none"> <li>• Displays 3D constructed image of the skin surface.</li> <li>• Accessible with CT, MR, and other modality image sets.</li> <li>• <b>Skin</b> thresholding is available for this view type.</li> <li>• <b>Clipping Range</b> and <b>Cubic Cut</b> are available for this view type.</li> </ul>
	<b>Digital Radiography (DRR)</b>	<ul style="list-style-type: none"> <li>• Allows viewing of digitally reconstructed radiography views arranged in 3D.</li> <li>• Accessible with a CT image set.</li> <li>• Thresholding is not available with this view type.</li> <li>• The <b>Clipping Range</b> is available, but the <b>Cubic Cut</b> function is not available for this view type.</li> </ul>
	<b>Vessels</b>	<ul style="list-style-type: none"> <li>• Displays only the vessels within the 3D view.</li> <li>• Accessible with a MR image set.</li> <li>• <b>Vessels Highlighting</b> is available with this view type.</li> <li>• <b>Clipping Range</b> and <b>Cubic Cut</b> are available for this view type.</li> </ul> <p><i>NOTE: Vessel structures may appear insufficiently if not using MR Angio or MR Contrast data. If so, other types (e.g., planes) should be preferred.</i></p>



Icon	View Type	Explanation
	<p><b>Maximum Intensity Projection (MIP)</b></p>	<ul style="list-style-type: none"> <li>• Allows volume visualization for 3D data which projects the voxels with the maximum intensity along the viewing direction in the visualization plane.</li> <li>• Available with CT, MR, PET, and other modality image sets.</li> <li>• Thresholding is not available with this view type.</li> <li>• <b>Clipping Range</b> is available, but the <b>Cubic Cut</b> function is not available for this view type.</li> </ul> <p><i>NOTE: The bone must be cut away to view the vessels in CT images. This can be done within <b>Options &gt; 3D Clipping</b> and selecting the <b>Clipping</b> option and then adjusting the bounding box located within the view.</i></p>

---

**Additional Warning for Advanced 3D View Types**



Depending on image resolution, contrast and individual patient anatomy, critical anatomical conditions may not appear or appear masked in the 3D renderings. 3D rendered structures must always be verified in 2D reconstructions or original slices, see page 98 for further information.

## 6.2.1 Parallel 2D/3D Viewing

### General Information

The **2D View Center Position** is displayed as a 2D blue/yellow cross hair ② in 2D reconstructions or slices while in parallel displays a small blue 3D cross ① (with three axes) within the 3D view (e.g., when the icon button **Pan/Recenter** is activated or while pressing **Ctrl** key to activate similar functions). For more view centering options (see page 284).

### How to Access Center of 2D Views

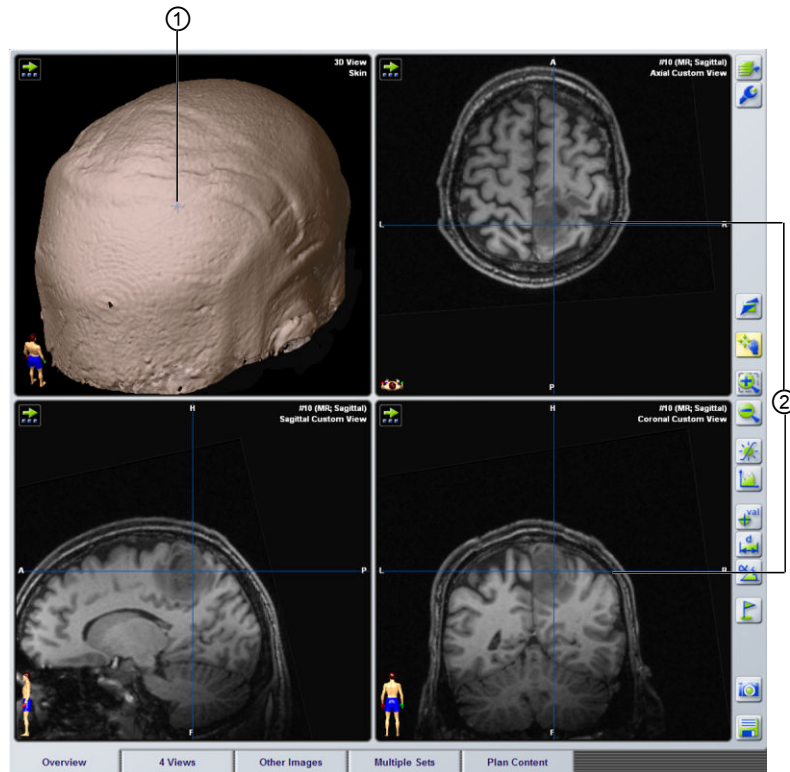

Figure 46

The small blue 3D cross hair ① can be accessed in the following ways:

Options
Select the <b>Pan/Recenter</b> icon.
Press and hold down the <b>Ctrl</b> key on the keyboard.

*NOTE: The small blue 3D cross hair ① only remains visible while the **Ctrl** button is pressed.*

## 6.3 Advanced 3D Thresholding

### Overview

#### General Information

In **Advanced 3D Thresholding** the threshold is defined interactively by using adjustable sliders located within the 3D rendered view. For more information on **3D Thresholding** (see page 99).

#### How to Use 3D Thresholding

Within this view, thresholding for **Bone** and **Skin** can be selected in addition to **Vessels Highlighting**.

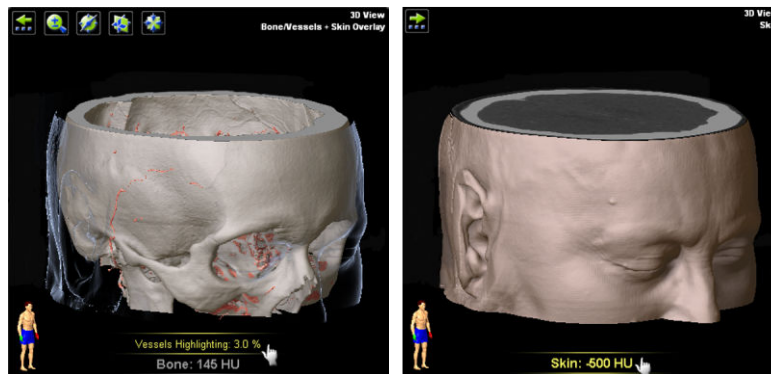



Figure 47

Steps	
1.	 Click <b>Windowing</b> to activate the threshold slider in the 3D viewing window. <i>NOTE: Not all threshold options are available for all view types (see page 94).</i>
2.	Position mouse pointer on the preferred slider within the 3D view: <ul style="list-style-type: none"> <li>• The <b>Skin</b> thresholding changes the displayed surface of the skin (e.g., in the view type <b>Skin</b>).</li> <li>• The <b>Bone</b> thresholding changes the displayed surface of the bone and vessels (e.g., in the view type <b>Bone/Vessels</b>).</li> <li>• <b>Vessels Highlighting</b> increases/decreases percent of red coloring (e.g., in view type <b>Bone/Vessels</b>).</li> </ul>
3.	Hold the left mouse button while moving the slider left to decrease or right to increase the threshold/highlighting. <i>NOTE: To turn off <b>Vessels Highlighting</b> (red coloring), set the threshold to 0%.</i>



The structure based analysis and vessel highlighting may provide incorrect results if there is insufficient or inaccurate vessel highlighting. Vessel highlighting displayed in 3D must be verified in 2D views (axial, coronal, and sagittal reconstructions).

#### Functions of 3D Thresholding

Thresholding Options	
Skin	Adjust <b>Skin</b> threshold to the preferred level skin showing.

Thresholding Options	
Bone	<p>Adjust <b>Bone</b> threshold to the preferred level of bone and vessel surface.</p> <p><i>NOTE: Adjusting the <b>Bone/Vessels</b> also adjusts the amount of vessel surface to be seen.</i></p> <p>Select <b>Vessels Highlighting</b> and adjust highlighting of the vessels in red with the slider.</p>
Vessels Highlighting	<p>Adjust <b>Vessels Highlighting</b> to the preferred level of vessel is showing.</p>

*NOTE: There is no threshold adjustment for the cerebrum in the **Cerebrum**, **Cerebrum + Bone Overlay**, and **Cerebrum + Skin Overlay** view types.*

## 6.4 Advanced 3D Clipping

### Overview

---

#### General Information

**Standard 3D** allows you to clip bone or skin as shown in the view type 3D, whereas **Advanced 3D** allows you to clip cerebrum as shown in the view type **Cerebrum**, **Cerebrum + Skin Overlay**, and **Cerebrum + Bone Overlay**. For more information (see page 94).

For **Standard 3D** and **Advanced 3D**, cubic cut and clipping range must be defined in the **Viewing Options** dialog (see page 275). Unless you are in view type **Cerebrum**, no other created object is clipped or cut.

*NOTE: For **Cerebrum** view types, the planes resulting from clipping will show reconstructions from the image set in which the cerebrum was originally generated instead of the currently selected image set.*

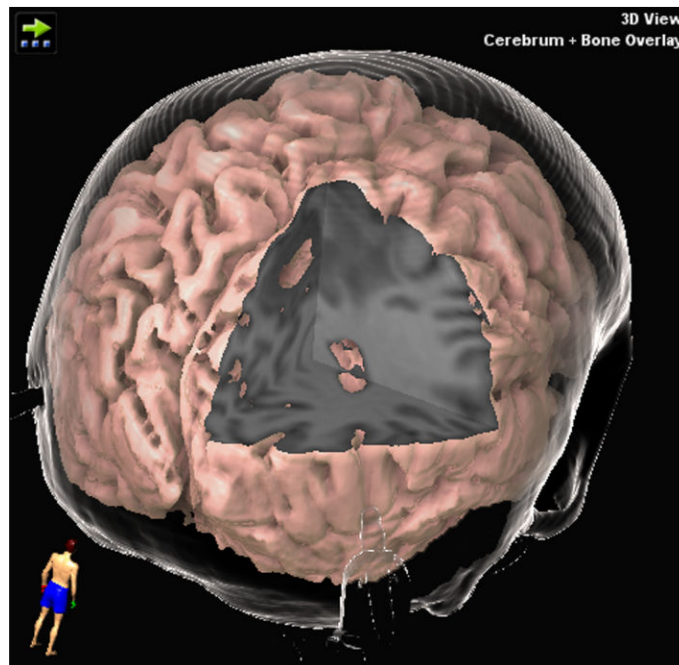

Figure 48



# 7 LOCALIZATION

## 7.1 Introduction

### Overview

---

#### General Information

With the Localization planning task, you can assign the localizer to the selected image set and perform stereotactic localization. Stereotactic localization provides a heading-specific coordinate system in which it is possible to calculate the arc settings for a planned trajectory.



**Stereotactic localization should be performed prior to planning trajectories or objects in the image set as well as prior to performing image fusion. Otherwise all previously performed image fusions are deleted. Other previously planned trajectories and objects will not be deleted, but may be changed. This occurs because the localization changes the volume data set, i.e. the slices are reoriented.**

---

#### Hardware

Carefully check the accuracy of your localization hardware on a regular basis.



**Localization is only possible in combination with fully functional hardware. If the localizer hardware is defective or damaged, or if the rod geometry is incorrect (see page 121), this can either cause localization to fail, or lead to incorrect results.**

---

#### Supported Images

Imaging modalities that cause image distortions (such as MR EPI data sets) or improper rod marker representation (due to poor contrast) cannot be properly localized.

*NOTE: Information on verifying image data is provided on page 56.*

## 7.1.1 Guideline for Performing Localization

### General Workflow

Workflow	
1.	Select an image set (see page 106).
2.	Select a localizer and heading combination and localize the image set using <b>Assign Localizer...</b>
3.	Verify each slice in the main view (by selecting individual slices in the catalog view). Use the color-coding of the slices as a guideline for verification (see page 108). Following verification, proceed to the next planning task.

If slices could not be successfully localized (see page 110):

Workflow	
1.	To ignore slices that are located beyond the localizer rod geometry (and could therefore not be localized), select the relevant slices and click <b>Ignore</b> . This will localize slices based on their relative position to the nearest localized slice.
2.	To repeat the localization process, click Localize.

If there are still unlocalized slices remaining (see page 111):

Workflow	
1.	Use <b>Add New</b> to manually add rod markers in slices where not all rod markers could be detected.
2.	To repeat the localization process, click Localize.
3.	If required, use <b>Position</b> to reposition rod markers that have been detected with low precision or in the incorrect position. The rod marker with the poorest localization result is displayed in yellow.
4.	To repeat the localization process, click Localize.

If slices cannot be localized manually due to e.g., insufficient rod marker definition (see page 110):

Workflow	
1.	Use <b>Ignore</b> to ignore intermediate slices (unless contraindicated, see page 110).
2.	To repeat the localization process, click Localize.

### Failed Localization

If no slices could be localized:

Steps	
1.	Check the assigned localizer.
2.	If the wrong localizer has been selected, assign the correct localizer and repeat localization.
3.	Proceed according to the steps described on page 104.

If the correct localizer was assigned and still no slices can be localized, check the windowing settings and perform a manual localization of two slices.



Steps	
1.	 Click the <b>Advanced Windowing</b> button to open the <b>Windowing</b> dialog (see page 287).
2.	Adjust the left and right threshold values so that all rods are clearly visible, with few artifacts. <i>NOTE: The left and right threshold values should be equal.</i>
3.	Click <b>OK</b> to confirm your settings and close the dialog.
4.	Click <b>Localize</b> .

If the correct localizer was assigned and still no slices can be localized, perform a manual localization of two slices.

Steps	
1.	Click <b>OK</b> to confirm your settings and close the dialog.
2.	Click <b>Localize</b> .
3.	If no slices could be localized, select one slice at the top of the localizer and localize it manually by positioning marker rods. Do the same for another slice at the bottom of the localizer.
4.	Click <b>Localize</b> .

*NOTE: If slices still cannot be localized, contact Brainlab support.*

## 7.2 Localizing the Image Set

### Selecting the Image Set and Assigning a Localizer

#### General Information

The first step in performing localization is localizer assignment. This provides a frame of reference for the slice set. Available localizers are listed on page 113.

#### How to Localize the Image Set

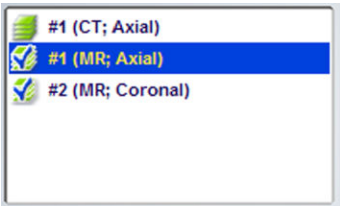
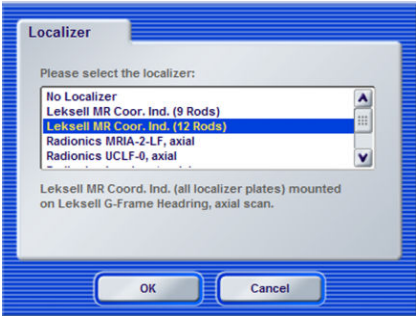
Steps	
1.	 <p>Select the image set from the <b>Image Sets</b> box in the functions area.</p>
2.	Click <b>Assign Localizer...</b>
3.	 <p>Select a localizer and heading combination from the <b>Localizer</b> dialog, making sure to select the same combination that was used during scanning.</p>
4.	Click <b>OK</b> to localize the first image set.



**You must select the correct localizer/heading combination for localization. If an incorrect combination is selected (e.g. correct localizer but incorrect heading), all slices will be successfully localized, however, the subsequent coordinate system will be incorrect.**

#### Third-Party Export

To facilitate subsequent export, the option **No Localizer** should be selected. This removes modifications to the original slice distance and slice orientation that occur as a result of localization.

## 7.2.1 Localization Result

### Localization Status Report

The software localizes the available slices and displays a status report of the localization.

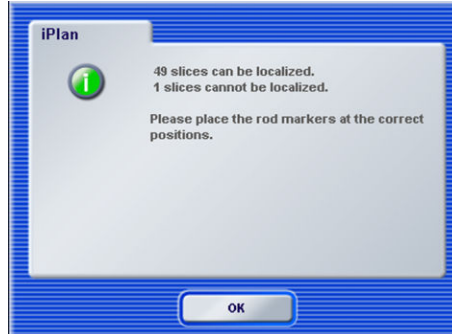

Figure 49

<b>Step</b>
Click OK to open the main screen.

### Main Screen After Localization

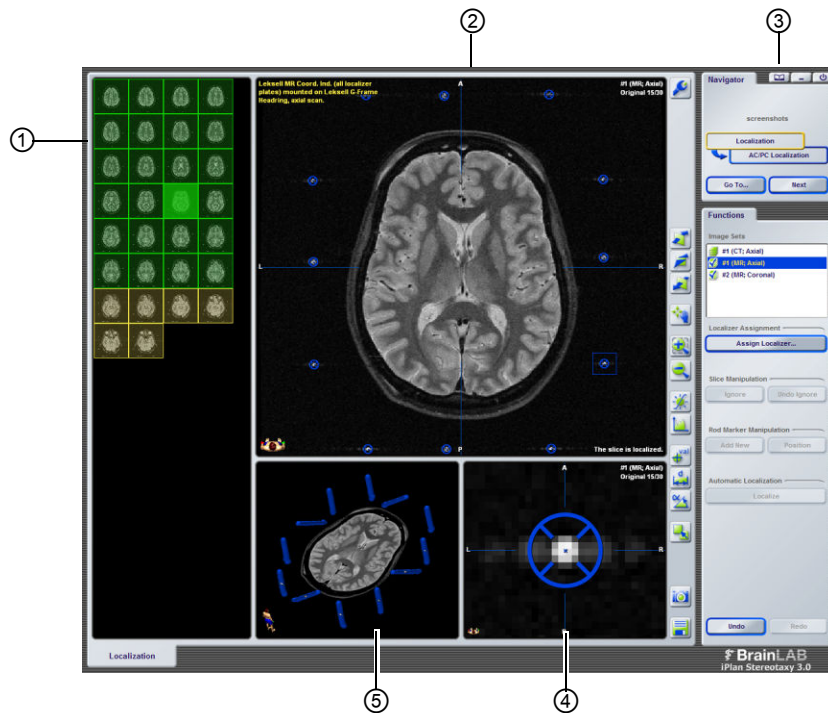



Figure 50

### Screen Explanation

No.	View	Explanation
①	Catalog	Depending on the localization result, the color of the slices varies: <ul style="list-style-type: none"> <li>• Green: Slice successfully localized</li> <li>• Yellow: Slice has been localized, but precision is low due to one or more misplaced rod markers, poor image quality or an inaccurate localizer geometry</li> <li>• Red: Slice could not be localized. Several reasons are possible, e.g., detection of too few rods.</li> </ul>
②	Main	Shows the slice currently selected in the catalog view. The assigned localizer and heading are indicated (upper right corner) and whether the image slice could be localized (lower left corner). Rod marker colors: <ul style="list-style-type: none"> <li>• Green: Localized rod markers</li> <li>• Yellow: Rod markers with poorest localization result</li> <li>• Blue: Indicates that some, but not all rod markers could be localized</li> </ul>
③	Functions area	Use the functions to modify the localization as needed.
④	Magnified	 <p>Shows a magnified view of the area indicated by the blue contoured rectangle in the main view. Use this view to better examine the position of a particular rod marker.</p> <p>To magnify another area, click the Move Magnifier button and drag the rectangle to the required location.</p> <p><i>NOTE: The magnified view is moved automatically when adding or positioning rod markers.</i></p>
⑤	3D	3D view of all detected rod markers in slice Use this view to verify the localizer rod geometry and identify slices with misplaced rod markers. Rod markers should reconstruct in a straight line.

### Verifying Localization

Carefully visually verify the contents of each view, in order to ensure that localization has been successful.



**Verify that every slice has been localized correctly, e.g., using the 3D view. Even if the software indicates that a slice has been localized successfully (displayed in green in the catalog view) the slice must be checked. For example, the arrangement of the rods may be correct, but due to artefacts, the rod geometry as a whole may be displaced.**

### Rod Marker Positions

If a gantry tilt is used for CT scans, or if a scan is oblique (MR), the image slices must still intersect the rods of the localizer at a perpendicular angle. Refer to the scanning instructions for acceptable gantry tilt or oblique angles.

### How to Modify the Orientation

The 3D orientation of the displayed localizer geometry is indicated by the patient icon at the bottom left of the views. If necessary, you can modify the orientation.

<b>Steps</b>	
1.	Position the mouse pointer on the patient icon.
2.	Hold down the left mouse button and move the mouse pointer until the required orientation has been achieved.

*NOTE: The correct placement of rod markers depends on the selected stereotactic localizer.*

**Next Steps**

<b>Options</b>
If the image set was successfully localized, continue to subsequent planning steps by clicking <b>Go to...</b> or <b>Next</b> in the <b>Navigator</b> area.
If not all slices were successfully localized, use the localization functions (see page 110) to manually correct the localization. <i>NOTE: You can also proceed according to the localization workflow provided on page 104.</i>

## 7.3 Localization Functions

### Ignoring Slices

#### When to Ignore Slices

The **Ignore** function allows you to localize slices with insufficient rod marker definition. This includes slices for which it is not even possible to manually position rod markers (see page 111). When you ignore such slices, the slices are localized based on their relative position to the nearest localized slice.

The **Ignore** function does not delete slices from the localization.

*NOTE: The **Ignore** function is contraindicated if you are using scans during which the patient moved around, resulting in the patient anatomy being scanned at irregular slice positions. The software is not able to recognize such irregularities.*



**Ignored slices of a data set may lead to an inaccurate localization as a result of not using all available rod marker information for localization. The user must make sure to localize as many slices as possible so that the localization precision of each slice is as high as possible. Only ignore slices that cannot be localized manually.**

#### How to Ignore Single Slices

Steps	
1.	Select the slice in the catalog overview.
	Click <b>Ignore</b> .
2.	The localization result is updated and the slice color in the catalog overview changes from red/yellow to gray.

#### How to Ignore Multiple Consecutive (Intermediate) Slices

Steps	
1.	Press SHIFT on the keyboard and select the first slice to be ignored. Keeping SHIFT pressed, select another slice to be ignored.
	Click <b>Ignore</b> . The selected slices and all those in between are ignored from the localization.
2.	The localization result is updated and the slice color in the catalog overview changes from red/yellow to gray.

#### Localizer Hardware



**Localization is only possible in combination with reliable hardware. If the localizer hardware is defective due to, for example, bubbles in the rods, localization will not be possible.**

## 7.3.1 Adding and Positioning Rod Markers

---

### When to Add or Position Rod Markers

You can manually add rod markers to the slice if the software is not able to localize a slice because an insufficient number of rod markers have been detected, due to e.g., bubbles in the rods, unfavorable scan parameters, or T1/T2 weighting.

You can reposition rod markers in the selected image slice if a slice cannot be localized due to marker rods that were incorrectly or inaccurately positioned.

---

### How to Add Markers

Steps
1. Select the desired slice in the catalog overview and click <b>Add New</b> .
2. Click on the slice to insert the rod marker.
3. Click in the magnified view to finely adjust the marker position as needed.
4. Continue in this way until the required amount of rod markers have been added.

*NOTE: The **Add New** function is deactivated when a sufficient number of markers has been added.*

---

### How to Position Rod Markers

Steps
1. Click <b>Position</b> .
2. Hold down the left mouse button and drag the selected rod marker to the required position.

---

### How to Repeat Image Slice Localization

Step
After you have manually modified rod markers, click <b>Localize</b> .

*NOTE: The software displays a message at the bottom of the functions area informing you whether localization is necessary.*





# 8 STEREOTACTIC LOCALIZERS

## 8.1 Rod Marker Geometries

### Overview

---

#### General Information

Depending on the type of stereotactic localizer that you select (see page 106) and the scan modality and orientation, the number of rod markers and their geometry may vary.

The tables in this section provide information on the rod marker geometry for your localizer.

### 8.1.1 Brainlab Localizer

#### Brainlab CT/X-Ray Localizer

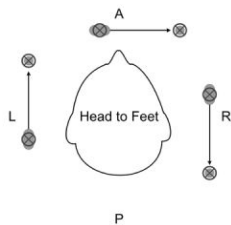
Scan Modality/Orientation	Rod Marker Geometry
CT/axial	

8.1.2 Leksell Localizers

Leksell MR/CT Coordinate Indicators

Scan Modality/Orientation	Rod Marker Geometry
MR/coronal	
MR/sagittal	
MR/axial (including backplate)	
MR/axial (without backplate)	
CT/axial	

### 8.1.3 Radionics Localizers

#### Radionics BRW-LR

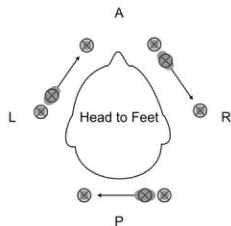
Scan Modality/Orientation	Rod Marker Geometry
CT/axial	

#### Radionics UCLF/Luminant

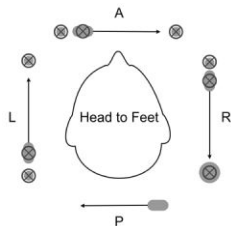
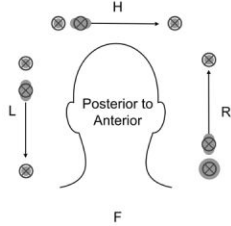
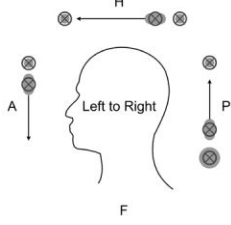
Scan Modality/Orientation	Rod Marker Geometry
CT and MR/axial	
MR/coronal	
MR/sagittal	

Radionics MRIA-2-LF

Scan Modality/Orientation	Rod Marker Geometry
MR/axial	
MR/coronal	
MR/sagittal	

### 8.1.4 Fischer Localizers

#### Fischer Rev. A

Scan Modality/Orientation	Rod Marker Geometry
CT/axial (upmount)	
CT/axial (downmount)	

#### Fischer Rev. O

Scan Modality/Orientation	Rod Marker Geometry
CT/axial (downmount)	

#### Fischer Rev. U

Scan Modality/Orientation	Rod Marker Geometry
CT and MR/axial (including frontplate)	

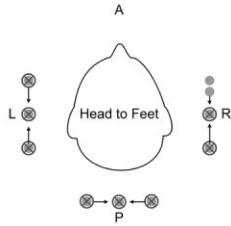
Scan Modality/Orientation	Rod Marker Geometry
<p>CT and MR/axial (without frontplate)</p>	 <p>The diagram illustrates the rod marker geometry for CT and MR/axial scans. It features a central head outline labeled "Head to Feet". Above the head is the letter "A", and below it is "P". To the left of the head is "L", and to the right is "R". On the "L" side, there are three rod markers (represented by circles with an "X") arranged vertically. On the "R" side, there are three rod markers arranged vertically. On the "P" side, there are three rod markers arranged horizontally.</p>





# 9 SUPPORTED ARC SYSTEMS

## 9.1 Brainlab Stereotactic System

### Arc System Settings

---

#### General Information

The range of scales S1, S2, S3, S5, and S6 supported by iPlan is limited according to the mechanical restrictions of the arc system.

The surgeon must ensure the mechanical stability of the fixation mechanisms.

We recommend using the scales only in the ranges indicated in the table. Should you need a larger range, contact Brainlab support.



---

#### Recommended Ranges

Scale	Location	Range
S1	Millimetrical ruler, mounted to headring	65P...90A [mm] for lat. left mount 90P...65A [mm] for lat. right mount 90R...65L [mm] for frontal mount
S2	Millimetrical tube	5R...90L [mm] for lat. left mount 90L...5R [mm] for lat. right mount 5P...90A [mm] for frontal mount
S3	Vertical Z-bar	0...85 mm
S5	Arc angle	22°...120°
S6	Ring angle	0°...360°

*NOTE: The usable range of scales may be limited either by the patient's head or by other arc system components, such as carbon fiber posts.*

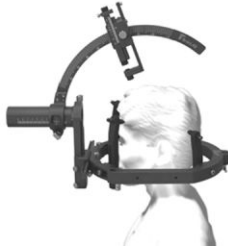
**Mounting Options**

Option	Illustration
Lateral left	
Frontal	
Lateral right	

*NOTE: Further information on adjusting the **Brainlab Stereotactic Arc** is provided in the **Stereotactic Arc Clinical User Guide**.*



Since the Brainlab localizer is a multi-purpose tool that is also used in combination with other applications, e.g., for radiosurgery, the arc range and localizer range differ. Therefore, targets planned in a localizable area might not be accessible with the Brainlab Stereotactic Arc. Please verify that the target is located within the arc range. The localizer must be mounted so that the target is accessible, i.e. approximately 0...80 mm above the localizer baseplate.

## 9.2 Elekta Leksell Micro-Stereotactic Systems

### Overview

---

#### General Information

iPlan supports:

- The Leksell Standard Stereotactic Arc
- The Leksell Multi Purpose Stereotactic Arc, mounted on the Leksell G-Frame Headring.

*NOTE: The Leksell Multi Purpose Stereotactic Arc is activated by default. If you prefer to use the Leksell Standard Stereotactic Arc, please contact Brainlab support.*

---

#### Leksell G-Frame Headring

The G-Frame Headring must be oriented on the patient's head with the removable front piece (anterior part of the frame) pointing towards the anterior portion of the patient's head.

Other orientations are not supported by iPlan.

## 9.2.1 Leksell Standard Stereotactic Arc

### General Information

The Standard Stereotactic Arc must always be mounted with the arc's engraved X-scale pointing towards the right side of the frame, thus to the right side of the patient's head. This mounting position is illustrated in the table.

The only mounting position of the Standard Stereotactic Arc supported by **iPlan** is the lateral right position. Other mounting options are not supported.

Although reverse mounting of the arc (engraved X-scale pointing to the left side of the frame so that the arc's X-scale matches with the frame's X-scale) is mechanically possible and advantageous in certain cases, iPlan does not support this option.

Please consult the arc manufacturer's manual for further information.

### Leksell Standard Mounting

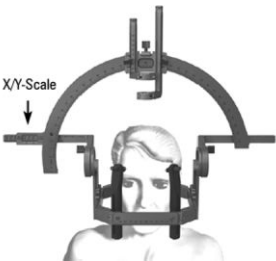
Option	Illustration
Lateral right (X/Y-scale see arrow)	

## 9.2.2 Leksell Multi Purpose Stereotactic Arc

### Recommended Ranges

Scale	Range
X	40...160 mm
Y	25...175 mm
Z	65...160 mm
Arc angle	0° ...167°
Ring angle	0° ...360°

### About the Mounting Positions

The mounting position of the Leksell Multi Purpose Stereotactic Arc is the side of the arc where the X- and Y-scale can be read.

In the lateral right position for example (see table), the scales point to the right side of the frame and the patient's head respectively.

Position	Comment
Sagittal anterior	The arc's Y-scale matches with the frame's Y-scale. Therefore, the Y-value must be read for sagittal anterior and sagittal posterior mountings.
Sagittal posterior	
Lateral left	The arc's X-scale matches with the frame's X-scale. Therefore, the X-value must be read for lateral left and lateral right mountings.
Lateral right	

### Leksell Multi-Purpose Mounting Options

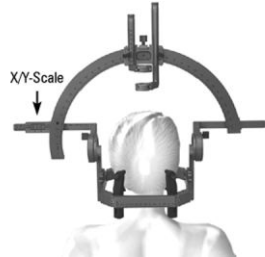
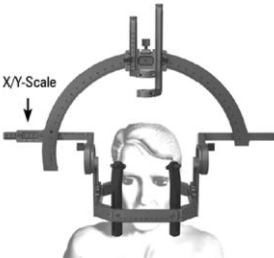
Option	Illustration
Lateral left (X/Y-scale, see arrow)	
Lateral right (X/Y-scale, see arrow)	

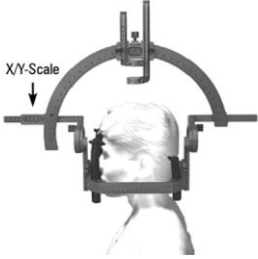
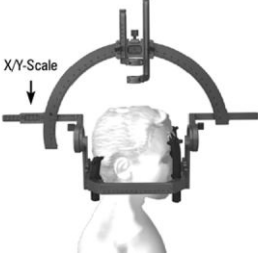
Option	Illustration
Sagittal anterior (X/Y-scale, see arrow)	
Sagittal posterior (X/Y-scale, see arrow)	

Radionics CRW ASL Arc System  
Arc System Settings

### Recommended Arc Ranges

Scale	Range
A-P	-100...100 mm
Lateral	-100...100 mm
Vertical	-67...65 mm
Arc angle	60°...0°...60°
Ring angle	-30°...90°...-30°

### Mounting Options

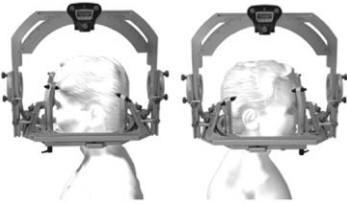
Option	Illustration
Probe carrier anterior or posterior (trunion rings are in the left-to-right position)	

Option	Illustration
<p>Probe carrier lateral left or lateral right (trunion rings are in the front-to-back position)</p>	

## 9.3 Fischer Leibinger Arc System

### Arc System Ranges

---

#### General Information

iPlan allows for mechanical restrictions and ensures the overall stability of the Fischer Leibinger ZD Arc System by limiting the adjustable range of scales.

The supported range of settings is therefore restricted compared to the arc system. iPlan supports the ranges indicated in the table.

Should you need a wider range, contact Brainlab.

---

#### Recommended Ranges

Scale	Location	Range
A1	Right-angled drum axle	0 mm...65 mm
A2	Right-angled drum axle	20 mm...0 mm
B1	Fixation rail	0 mm...75 mm
B2	Fixation rail	75 mm...0 mm
C	Right-angled drum	0 mm... 105 mm
D1	Drum axle	0°... 360°
E	Arc	20°... 110°



### 9.3.1 Arc System Settings: Upmount Orientation



#### Arc Setting Module Scale

The following table shows the relation between the stereotactic coordinate axes and the arc setting modules (scales) for the upmount orientation:

Position of the ZD Arc on the Headring	Stereotactic Coordinate Axes	Corresponding Scale of the ZD Setting Module
0°, anterior	+X (-X) +Y (-Y)	B2 (B1) A1 (A2)
90°, lateral right	+X (-X) +Y (-Y)	A1 (A2) B1 (B2)
180°, posterior	+X (-X) +Y (-Y)	B1 (B2) A2 (A1)
270°, lateral left	+X (-X) +Y (-Y)	A2 (A1) B2 (B1)

#### Mounting Options

The following table shows the options for the upmount orientation:

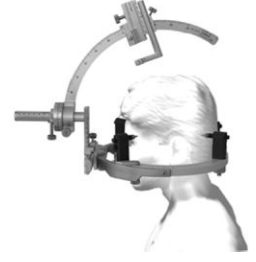
Option	Illustration
270°, lateral left	
90°, lateral right	
0°, anterior	

Option	Illustration
180°, posterior	

### 9.3.2 Arc System Settings: Downmount Orientation



#### Arc Setting Module Scale

The following table shows the relation between the stereotactic coordinate axes and the arc setting modules (scales) for the downmount orientation:

Position of the ZD Arc on the Headring	Stereotactic Coordinate Axes	Corresponding Scale of the ZD Setting Module
0°, anterior	+X (-X) +Y (-Y)	B1 (B2) A1 (A2)
90°, lateral right	+X (-X) +Y (-Y)	A1 (A2) B2 (B1)
180°, posterior	+X (-X) +Y (-Y)	B2 (B1) A2 (A1)
270°, lateral left	+X (-X) +Y (-Y)	A2 (A1) B1 (B2)

#### Mounting Options

The following table shows the options for the downmount orientation:

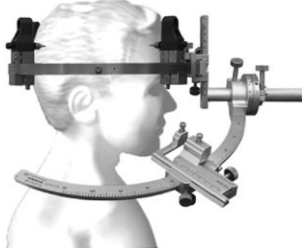
Option	Illustration
270°, lateral left	
90°, lateral right	
0°, anterior	

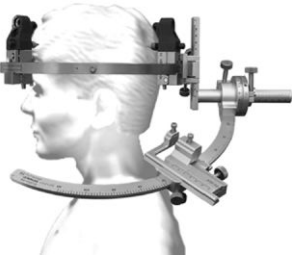
Option	Illustration
180°, posterior	 A grayscale illustration of a human head in profile, facing left. A complex metal stereotaxic arc system is mounted on the back of the skull. The system includes a horizontal bar across the top of the head, a vertical post, and a large curved arc that wraps around the back and sides of the head. Various adjustment knobs and screws are visible on the apparatus.

# 10 AC/PC LOCALIZATION

## 10.1 Introduction

### Overview

---

#### General Information

In **AC/PC Localization**, you can define the AC/PC system, which is determined by:

- The mid-sagittal plane
  - The positions at which the anterior commissure (AC) and the posterior commissure (PC) intersect the mid-sagittal plane
- 

#### When is AC/PC Localization Required?

**AC/PC localization** is required for:

- Patient orientation, which will be used for the alignment of the reconstructed views (e.g., axial, coronal and sagittal) in all upcoming planning tasks
- Trajectory planning based on definable AC/PC coordinates
- Matching of Schaltenbrand-Wahren atlas images to patient images

## 10.1.1 AC/PC Localization Functions

### Main Screen

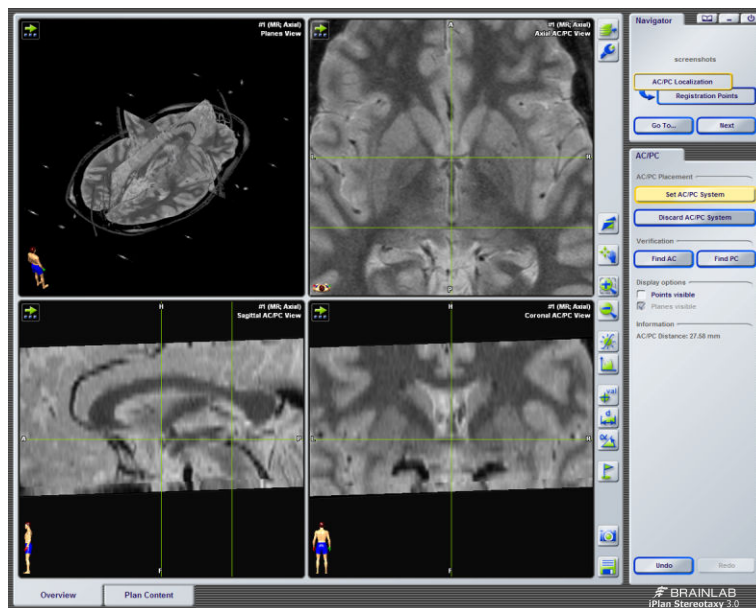

Figure 51

### Available Functions

Function	Explanation	See
Set AC/PC System	Define and adjust the AC/PC reference system in an image set	Page 135
Discard AC/PC System	Remove an AC/PC reference system that you defined	Page 136
Find AC	Find the AC point by centering it in the view	Page 136
Find PC	Find the PC point by centering it in the view	
Points visible	Show/hide AC and PC points in the image views	
Planes visible	Show/hide the AC/PC system planes in the image views	

## 10.2 Performing AC/PC Localization

### Defining the AC/PC System

#### How to Define the AC/PC System

Steps	
1.	<p>Click the <b>Slice and Image Set Selection</b> button and select the image set in which to place the AC/PC system.</p> <p><i>NOTE: An AC/PC system can only be defined in one image set. If you have already performed AC/PC localization, and then select another unfused image set in which to perform localization, the software asks if you would like to discard the previous AC/PC localization.</i></p>
2.	<p>Click <b>Set AC/PC system</b> in the functions area.</p> <p>The default AC/PC system is now displayed in the image views (see page 135) and can be modified as needed (page 136).</p> <p><i>NOTE: If you previously modified the AC/PC system, the modified system is shown, rather than the default.</i></p>

#### Displayed AC/PC System

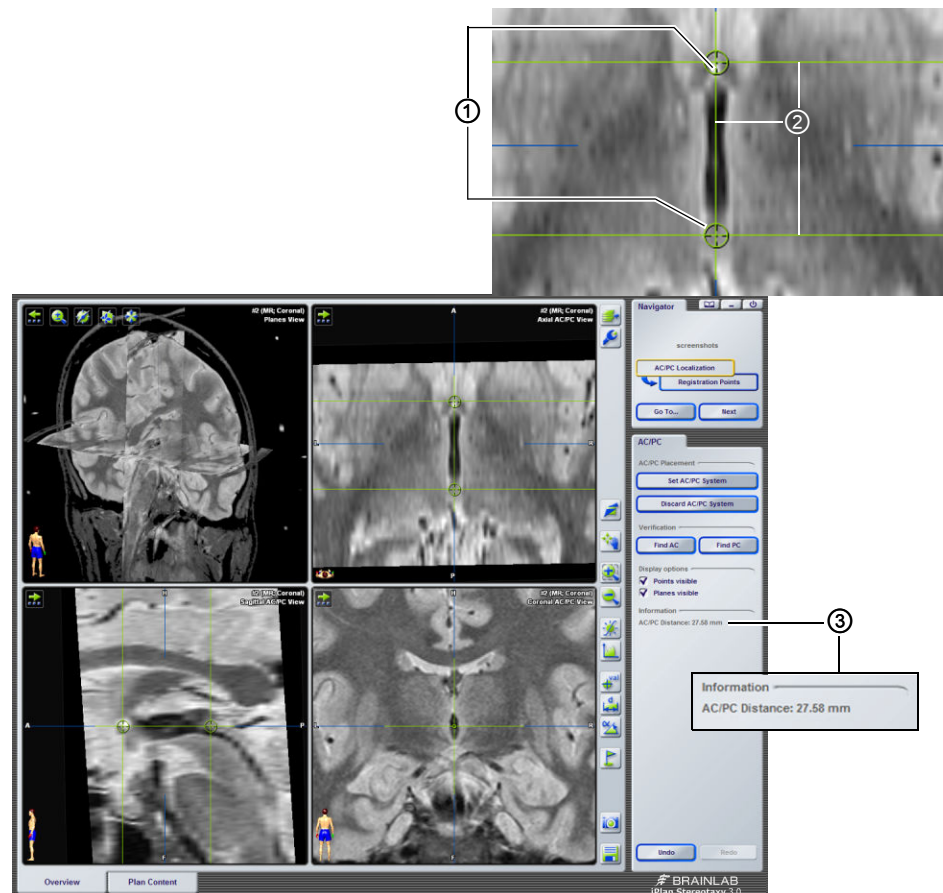

Figure 52

No.	Explanation
①	AC and PC points
②	AC/PC system planes (indicated by green lines)
③	Distance between AC and PC points

### How to Modify the AC/PC System

Once you have defined the AC/PC system, you can adjust the AC/PC points and planes in the image views in order to reposition the AC/PC system as needed.

Steps	
1.	<p>Ensure that the <b>Set AC/PC system</b> button is enabled (shown in yellow).</p> <p><i>NOTE: If you disable the <b>Set AC/PC system</b> button, the AC/PC system is still shown in the image views, however, you cannot reposition it.</i></p>
2.	<p>Place the mouse pointer onto the AC/PC system in any of the image views.</p> <p>Based on the placement of the mouse pointer, the section of the AC/PC system that can be adjusted is shown yellow. The mouse pointer also indicates the adjustment that is available (rotation or translation).</p>
3.	<p>Click the mouse pointer and drag the AC/PC system in order to reposition it.</p> <p>Various adjustments are possible. For example, you can adjust planes either by rotating them (mouse symbol shown as curved arrows), or dragging the plane up, down, left or right (mouse symbol shown as a straight arrow).</p> <p>When you adjust the reference system:</p> <ul style="list-style-type: none"> <li>• The image views reorient according to the adjusted AC/PC system position</li> <li>• The AC/PC distance in the functions area is updated</li> </ul>

### Viewing Options

Options
To recenter the view to the AC point, click <b>Find AC</b> .
To recenter the view to the PC point, click <b>Find PC</b> .
To show/hide the AC and PC points in the image views, enable/disable the <b>Points visible</b> check box.
To show/hide the AC/PC system planes in the image views, enable/disable the <b>Planes visible</b> check box.
<i>NOTE: This option is available only if the <b>Set AC/PC system</b> button is disabled. If the set AC/PC system is activated, the planes are always shown.</i>

### How to Discard the AC/PC System

Step
<p>Click <b>Discard AC/PC</b> system.</p> <p>The image views are reset to the original scan orientation.</p>



# 11 PLANNING REGISTRATION POINTS

## 11.1 Introduction

### Overview

---

#### General Information

In the **Registration Points** planning task, you can plan registration points in order to later perform marker-based image fusion and subsequent patient registration using Brainlab cranial/ENT navigation software.

You can manually add points to selected image sets or perform automatic marker detection in order to detect registration markers already present in the scanned images.

---

#### Registration Points Types

You can plan the following types of registration points:

- Landmarks: Anatomical or artificial (e.g., splints, nasion, implanted screws, etc.)
  - Donut Markers: Donut shaped markers visible in the image set
  - Sphere Markers: Sphere shaped markers visible in the image set
- 

#### Placing Registration Markers

To optimize registration of markers/landmarks during navigation, ensure that markers are placed on the patient according to the guidelines below:

- Do not place markers very close to each other, rather distribute them over the head
- Do not place markers symmetrically (e.g., do not place them in a line, or a symmetrical shape)
- Avoid areas with loose skin (to prevent skin shift)

## 11.1.1 Registration Points Functions

### Main Screen

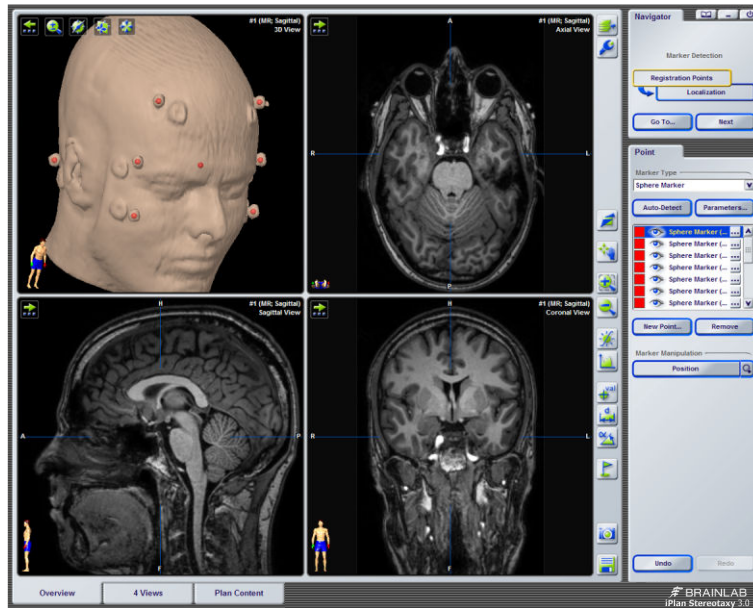

Figure 53

### Functions Overview

Function	Explanation	See
Marker Type	Select the registration point type that you would like to plan:	Page 139
	<ul style="list-style-type: none"> <li>• Landmark: Define manually</li> </ul>	
	<ul style="list-style-type: none"> <li>• Donut Marker: The software uses a semi-automatic detection method to detect donut shaped markers if present in the image set</li> </ul>	Page 140
	<ul style="list-style-type: none"> <li>• Sphere Marker: The software automatically detects sphere shaped markers if present in the image set</li> </ul>	Page 144
Auto-Detect	Automatically detect sphere markers	Page 144
Parameters...	Define the parameters for automatic marker detection (only available for sphere markers)	Page 142
List box	Lists registration points that you have added to the image set. From here you can modify the visibility, color, and properties of the registration points.	Page 148
New Point...	Manually add registration points to the image set	Page 139
Remove	Remove registration points from the image set	Page 146
Position	Adjust position of registration points in the image set	Page 146

# 11.2 Planning Points

## Adding Landmarks Manually

### General Information

This section describes how to manually add new registration points to the current image slice. You can use this function to define artificial or anatomical landmarks on the patient.

### How to Add Landmarks

Steps
1. In the <b>Marker Type</b> drop-down list, select <b>Landmark</b> .
2. Click <b>New Point...</b> to open the <b>Properties</b> dialog (see page 63).
In the <b>Name</b> field, enter a name for the point.
3. <i>NOTE: If you do not name the point, it is added to the list as <b>Landmark</b> and numbered sequentially.</i>
4. Click on the <b>Select Color</b> tab and select a color for the new point.
5. Click <b>OK</b> to confirm your settings and to add the point to the list in the functions area.
6. Position the point by clicking directly in the desired area on the image in 2D or 3D views.



**Make sure to verify planned landmarks in the 2D views.**

### Displayed Landmarks

The landmark selected from the list is shown circled in the image views.

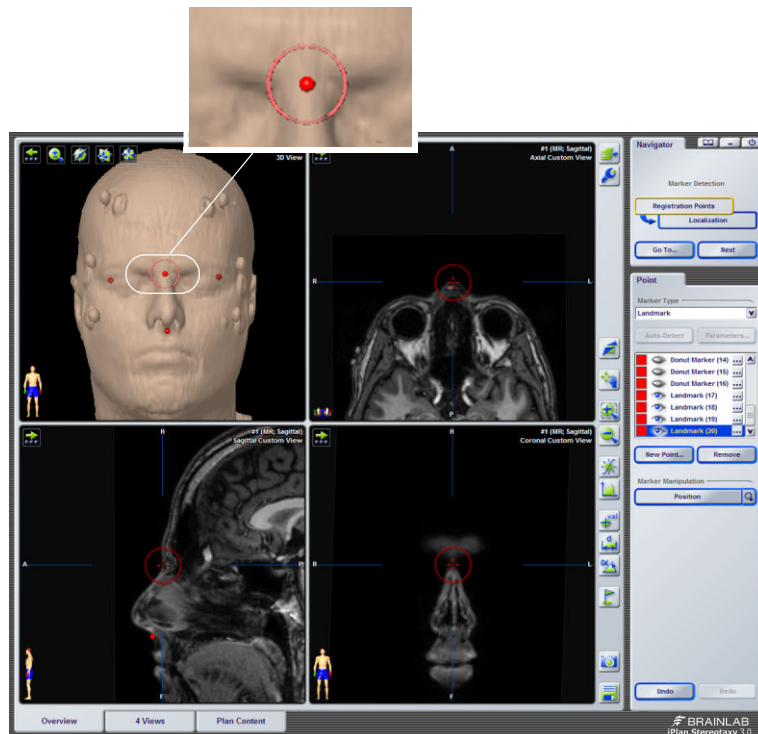

Figure 54

## 11.2.1 Defining Donut Markers

### General Information

This section describes how to detect donut markers that were attached to the patient before scanning and are therefore visible in the image set.

Donut markers are multi-modality fiducial markers for image guided surgery e.g., those manufactured by “IZI Medical Products”, or other markers with the same shape and dimensions.

A semi-automatic detection feature is available so that when you click near the center of the marker, the software places the point directly in the center.

### How to Add Donut Markers

Steps	
1.	In the <b>Marker Type</b> drop-down list, select <b>Donut Marker</b> .
2.	Click <b>New Point...</b> to open the <b>Properties</b> dialog (see page 63).
3.	In the <b>Name</b> field, enter a name for the point. <i>NOTE: If you do not name the point, it is added to the list as <b>Donut Marker</b> and numbered sequentially.</i>
4.	Click on the <b>Select Color</b> tab and select a color for the new point.
5.	Click <b>OK</b> to confirm your settings and to add the point to the list in the functions area.
6.	Click on the donut marker in the 2D or 3D view. The point automatically jumps to the center of the donut marker.



**Make sure to verify planned donut markers in the 2D views.**

### Displayed Donut Markers

The donut marker selected from the list is shown circled in the image views.

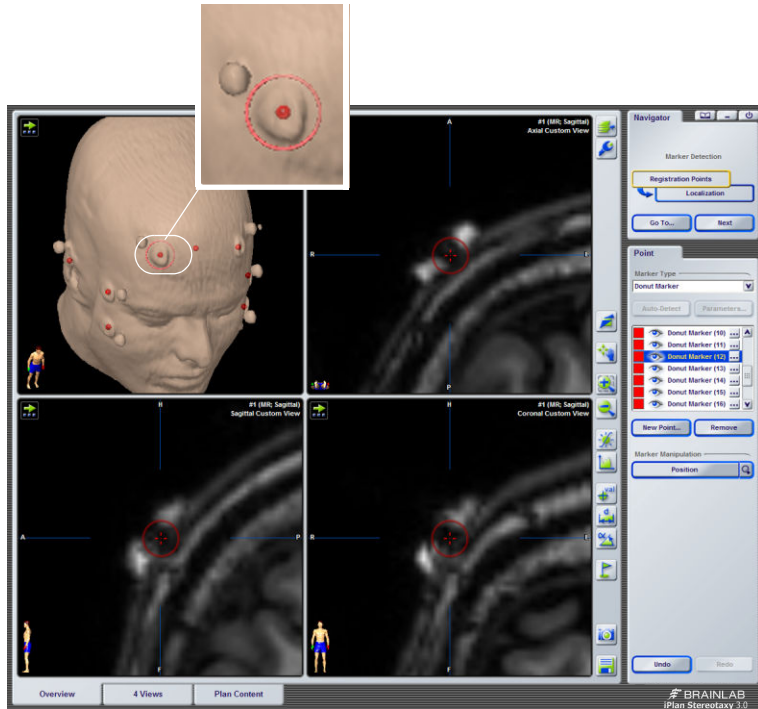

Figure 55

### Centered Donut Markers

Use the axial, coronal and sagittal views to ensure that the point is placed in the center of the donut marker.

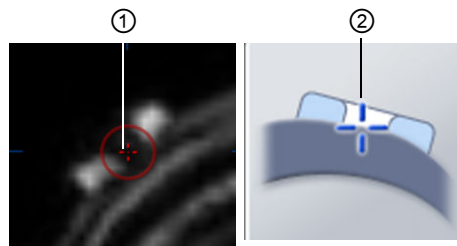

Figure 56

No.	Explanation
①	Example of a point centered in donut marker in a 2D view
②	Illustrated example of a point centered in donut marker

*NOTE: You can manually position donut markers (see page 146) if you would like to fine-tune the position.*

## 11.2.2 Defining Detection Parameters for Sphere Markers

### General Information

If you are going to perform automatic marker detection (see page 144) for sphere markers, the **Parameters** function allows you to customize the threshold and accuracy values required for the detection.

This function is useful, e.g, for preventing bone structures with the same density as the sphere markers from being detected and displayed as registration points in the image set.

*NOTE: The **Parameters** button is enabled only if you have selected **Sphere Marker** from the drop-down list in the functions area.*

### About the Parameters

Parameter	Explanation
<p style="text-align: center;"><b>Threshold</b></p>	<p>Determines how clearly the software can distinguish sphere markers on scan images from normal cell or bone tissue. When a suitable threshold is set, markers are detected as white spheres.</p> <p><b>CT markers</b></p> <ul style="list-style-type: none"> <li>• Density information is expressed in international Hounsfield units</li> <li>• The recommended range is 1200-1800</li> </ul> <p><b>MR markers</b></p> <ul style="list-style-type: none"> <li>• Density information is expressed in gray level values</li> <li>• The recommended range depends on the image set and the scanner manufacturer</li> </ul> <p><i>NOTE: These settings should only be adjusted if no sphere markers can be detected.</i></p>
<p style="text-align: center;"><b>Tolerance</b></p>	<p>Defines how far the shape of a sphere marker can deviate from the default value and still be detected.</p> <ul style="list-style-type: none"> <li>• A lower tolerance detects objects with a spherical shape</li> <li>• A higher tolerance detects objects with increasingly elliptical shapes</li> </ul> <p><i>NOTE: By default, a medium tolerance setting is defined in the software.</i></p>

**How to Define Parameters**

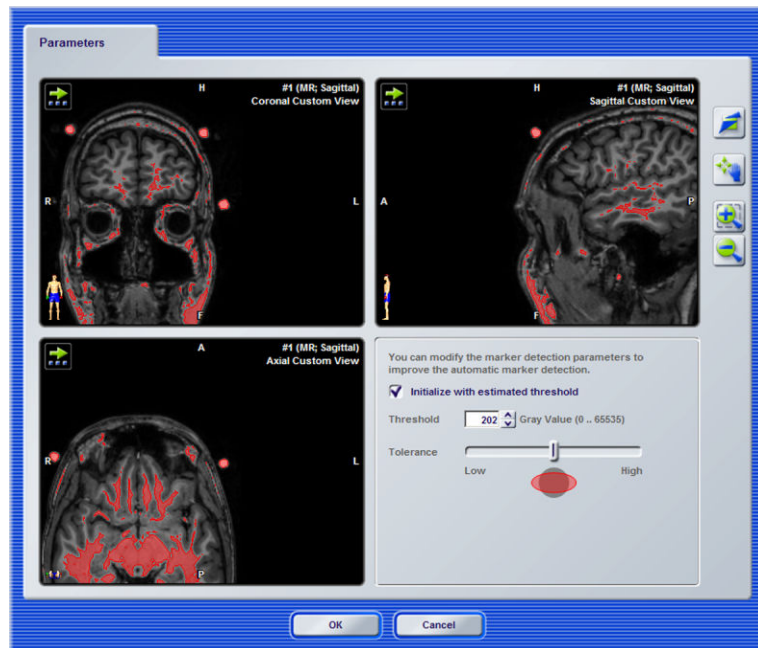

Figure 57

<b>Steps</b>	
1.	Click <b>Parameters...</b> in the functions area to open the <b>Parameters</b> dialog.
	As required, adjust the threshold values and use the <b>Tolerance</b> slider bar to adjust the tolerance.
2.	<i>NOTE: If you define a threshold value, it will be valid only for the current session. If you would like the defined value to be valid for all <b>iPlan</b> sessions, deactivate the <b>Initialize with estimated threshold</b> checkbox. If the <b>Initialize with estimated threshold</b> checkbox remains activated, the software calculates the value automatically the next time you start the software.</i>
3.	Click <b>OK</b> to apply the values to all image sets in the plan.

### 11.2.3 Automatically Detecting Sphere Markers

#### General Information

This section describes how to automatically detect sphere markers that were attached to the patient before scanning, and are therefore already present in the image set.

#### Detecting Markers

Steps	
1.	In the <b>Marker Type</b> drop-down list, select <b>Sphere Marker</b> .
2.	If required, adjust detection parameters (see page 142).
To automatically detect and display sphere markers, click <b>Auto-Detect</b> .	
3.	All detected sphere markers are displayed in the image views and added to the list in the functions area as <b>Sphere Marker</b> .



**Make sure to verify automatically detected markers in the 2D views.**

#### If Sphere Markers are not Detected

If sphere markers are not automatically detected, this may indicate that:

- Sphere markers were not attached to the patient before scanning
- Detection parameters need to be adjusted

*NOTE: Other structures may be detected as sphere markers. Therefore, once automatic detection is complete, review the markers and remove any that were incorrectly detected.*



### Displayed Sphere Markers

The sphere marker selected from the list is shown circled in the image views.

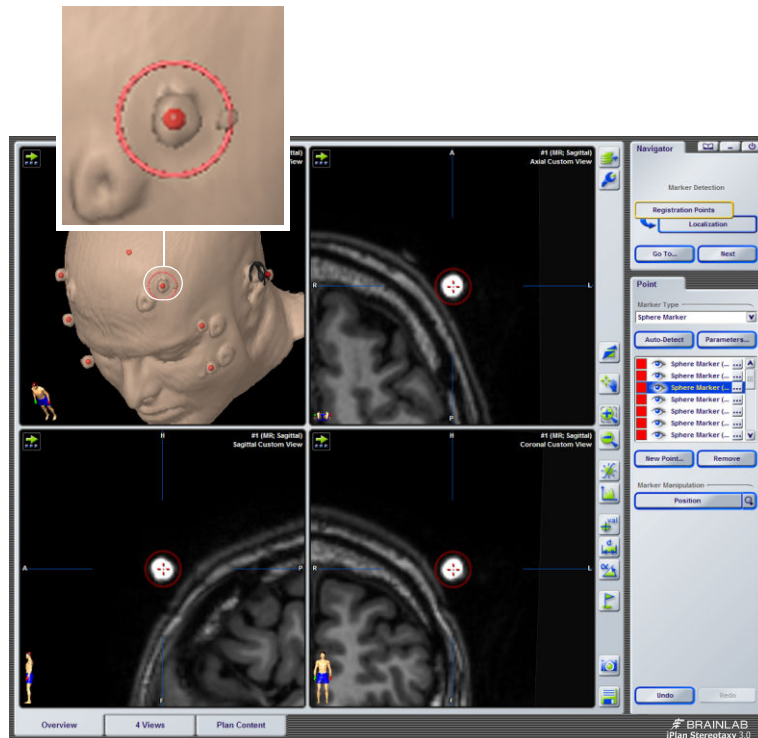

Figure 58

### Centered Sphere Markers

You can use the axial, coronal and sagittal views to visually inspect the detected sphere markers.

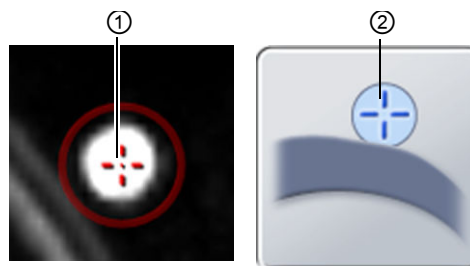

Figure 59

No.	Explanation
①	Example of a point centered in sphere marker in a 2D view
②	Illustrated example of a point centered in sphere marker

*NOTE: You can manually position sphere markers (see page 139) if, for example, they cannot be automatically detected, or are incorrectly positioned.*

## 11.2.4 Additional Functions

### How to Place Registration Points in Other Image Sets

If you would like to perform a marker-based image fusion (see page 160), you must select another image set and place registration points as previously described.

Steps	
1.	 <p>Click the <b>Slice and Image Set Selection</b> button and select the desired image set in the <b>Set Selection</b> dialog.</p> <p><i>NOTE: Make sure to select a slice which exhibits a similar amount of detail to the first set so that you can easily place the second row of registration points onto similar anatomical structures.</i></p>
2.	Click <b>OK</b> to confirm your selection and close the dialog.
3.	Add registration points to the image slice (see page 139 for landmarks, page 140 for donut markers, and page 142 for sphere markers).

### How to Remove Points

Steps	
1.	Select the named point from the list.
2.	Click <b>Remove</b> .

### How to Position Points

Steps	
1.	Click <b>Position</b> .
2.	<ul style="list-style-type: none"> <li>• Select the relevant point in the image with your mouse pointer and drag the point to the required position, or</li> <li>• Click on the required location in the image view.</li> </ul>

### How to Find Points

Step	
	<p>Select the point in the list, and click the magnifying glass icon (to right of the <b>Position</b> button).</p> <p>The point is now shown in the center of the view.</p>

# 12 IMAGE FUSION

## 12.1 Introduction

### Overview

---

#### General Information

**Image Fusion** allows you to fuse together two or more image sets with the same or different modalities (CT, MR, PET, SPECT).

Once two image sets are fused, all planned content (for example, objects and trajectories) defined in one image set is visible in the other image set.

---

#### Types of Image Fusion

Fusion Type	Explanation
Automatic	Fuses images together based on structures common to both image sets using a mutual information algorithm
Frame of Reference	Image sets that have been acquired during the same image acquisition session are automatically fused based on the DICOM tag "Frame of Reference"
Manual	Allows you to manually align two image sets together using the mouse pointer
Registration Point	Fuses images based on registration marker pairs defined in the images
Volumetric Information	Fuses image sets based on identical image set volume parameters

## 12.1.1 Image Fusion Functions

### Main Screen

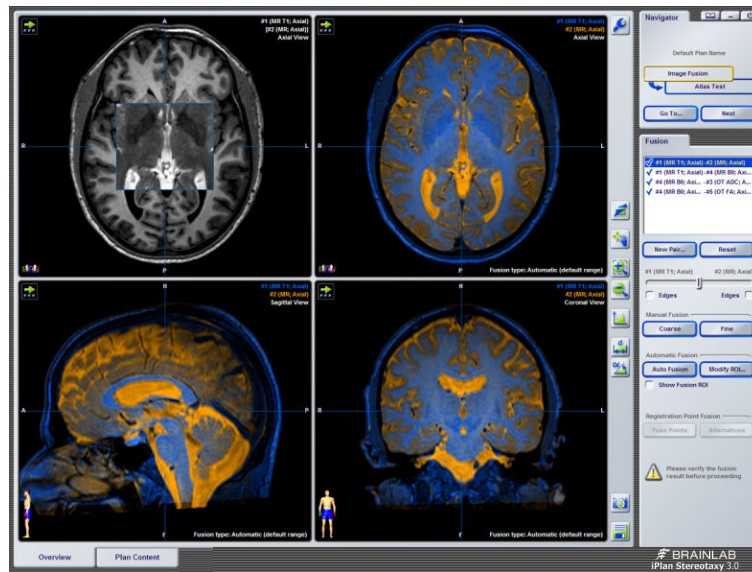

Figure 60

### Functions Overview

Function	Explanation	See
List box	Lists the image pairs available for fusion	Page 149
New Pair...	Define new or modify existing image fusion pairs	Page 149
Reset	Resets an image fusion so that image set positions are reset to initial positions defined by scanner	Page 155
Slider bar	Adjust blue/amber color overlay of the image pair	Page 151
Coarse	Perform manual fusion using large adjustments	Page 158
Fine	Perform manual fusion using small adjustments	Page 159
Auto Fusion	Start automatic fusion	Page 155
Modify ROI...	Select the region of interest to be used by the algorithm in order to achieve the best automatic image fusion result	Page 153
Show Fusion ROI	Display a frame in the image views that shows the defined region of interest	Page 154
Fuse Points	Activate image fusion based on registration points	Page 160
Alternatives	Display alternative results if you performed registration points fusion	Page 160

## 12.2 Selecting Images for Fusion

### Fusion Pairs

#### General Information

When you enter the **Image Fusion** planning task, the image pairs available for fusion are shown in the list view in the functions area.

- If the check box to the left of an image pair is ticked in blue, this indicates that the images are already fused.
- If the check box to the left of an image pair is ticked gray, this indicates that an image fusion has been performed based on “Frame of Reference” or “Volumetric Information” and therefore needs to be:
  - Verified by visual inspection, and
  - Confirmed by clicking on the checkmark

*NOTE: If you would like more information on the technical background of default fusion pairs, contact Brainlab support.*

#### How to Change Fusion Pairs

You can change the fusion pairs that are selected by default.

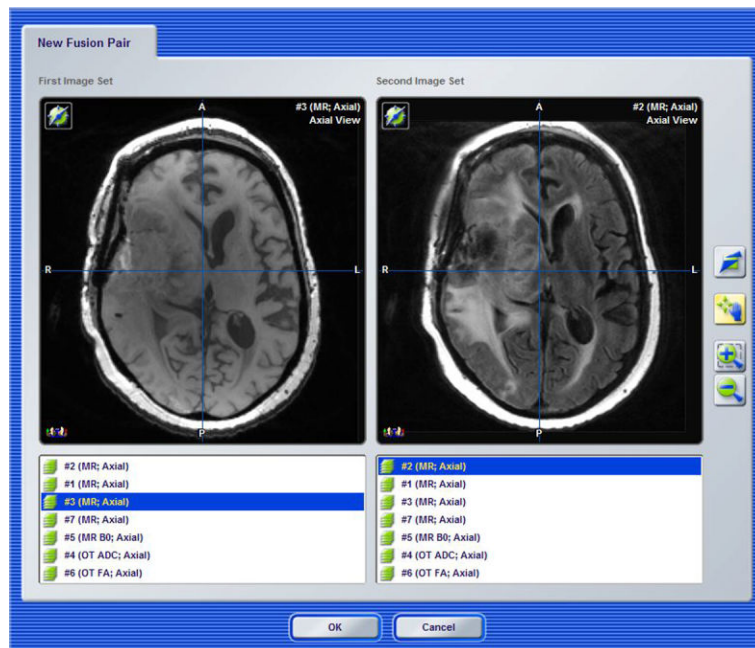

Figure 61

Steps	
1.	Click <b>New Pair...</b> in the functions area to open the <b>New Fusion Pair</b> dialog.
2.	Under <b>First Image Set</b> , select the alignment set to be used as a basis for image fusion.
3.	Under <b>Second Image Set</b> , select the image set to be adjusted to match the alignment set during image fusion.
4.	Click <b>OK</b> to confirm the selected image sets.

### Availability Fusion Pairs

If the combination of image sets is not possible, or if the selected image sets have already been fused, the **OK** button is deactivated.

In this case, you can select another image pair for fusion or use the **Reset** function to reset a fusion for an existing pair.

## 12.3 Optimizing the Image Display

### Adjusting the Image Contrast

#### General Information

To help distinguish between the image sets:

- The first image set is displayed in blue
- The second image is displayed in amber

For better comparison, you can adjust the brightness of the selected image sets using the slider bar in the functions area.

#### Adjusting Brightness



Figure 62

Options	
•	To reduce the brightness for the second image set (amber), drag the slider bar to the left.
•	To reduce the brightness of the first image set (blue), drag the slider bar to the right.
To show only the outline contours of a particular image set, enable the appropriate <b>Edges</b> check box.	

#### Example Fusion View

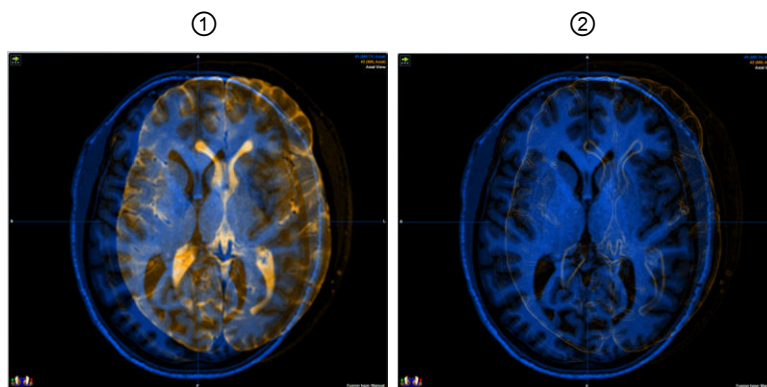

Figure 63

No.	Explanation
①	Standard amber/blue display
②	Display with <b>Edges</b> check box for amber enabled

## 12.3.1 Adjusting Image Windowing

### General Information

You can define advanced windowing settings individually for each image set (amber and blue). Adjusting these settings allow you to distinguish more easily between the image sets.

### How to Adjust Windowing

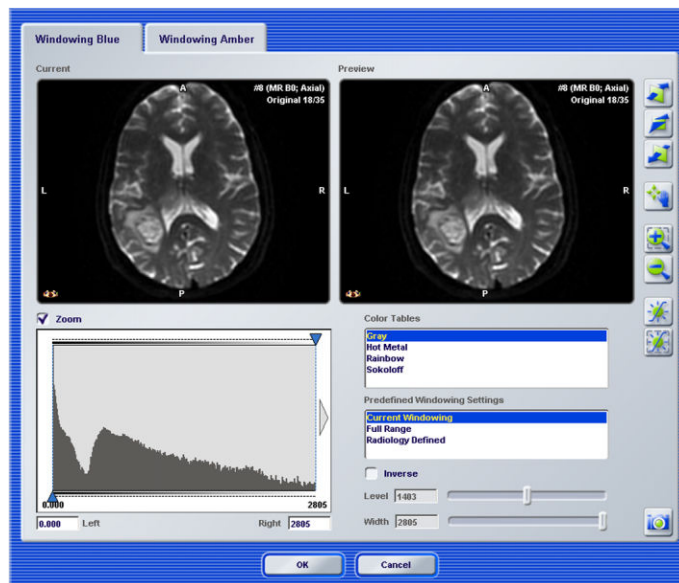



Figure 64

Steps	
1.	 Click the <b>Advanced Windowing</b> function in the toolbar to open the <b>Windowing Blue</b> and <b>Windowing Amber</b> tabs.
2.	Adjust the windowing settings as described on page 287.
3.	Click <b>OK</b> to apply your settings to the selected images.



## 12.4 Performing Image Fusion

### Defining the Fusion Area

#### General Information

When you enter the **Image Fusion** planning task, the fusion region that is set by default may be suitable in many cases.

However, before you perform an automatic fusion (see page 155), you should examine the region of interest in the image which is used for the fusion, and if needed, modify it using the **Modify ROI...** function. You should define a region of interest that is large enough to include all relevant structures for the treatment while leaving structures that are not relevant outside of the frame.

The software then uses the defined area as the reference for the fusion in order to achieve the best accuracy for the target area.



**The fused area inside the frame will be more accurate. However, the area outside the frame will be fused less accurately.**

#### How to Modify the Fusion Region of Interest

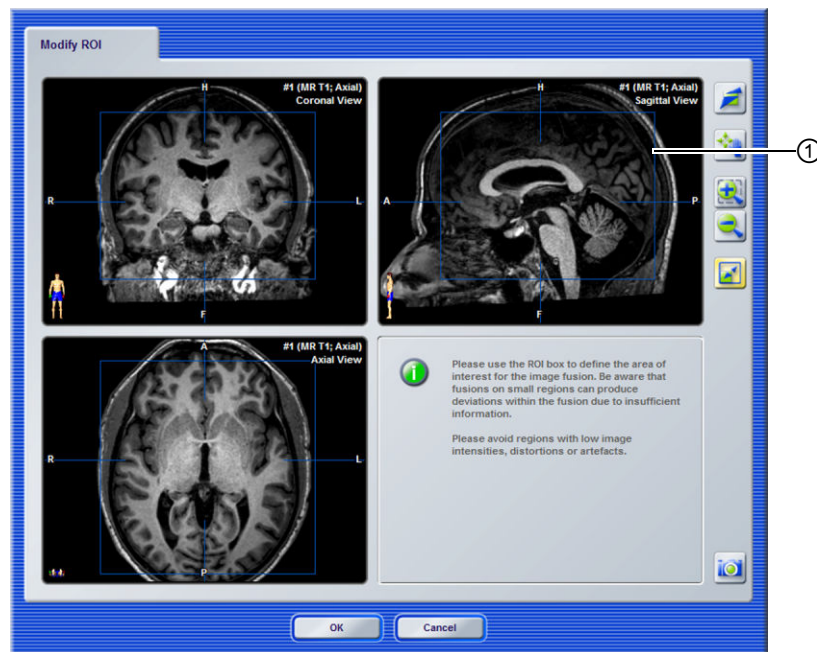



Figure 65

Steps	
1.	Click <b>Modify ROI...</b> in the functions area to open the <b>Modify ROI</b> dialog.
2.	 Click the <b>Adjust Fusion Region</b> button in the toolbar and place your mouse on the frame ① in the image view.
3.	Adjust the frame so that it surrounds the area to be used as the fusion reference.
4.	Click <b>OK</b> to confirm the fusion area.

---

## Displaying the Region of Interest

You can display the defined region of interest in the image views.

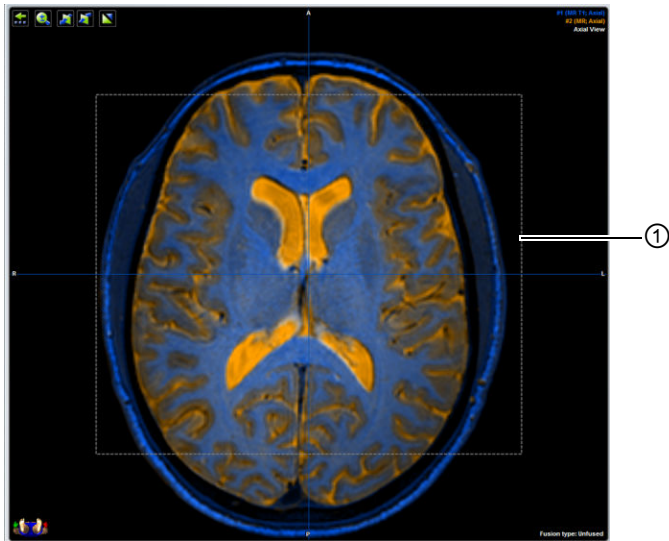

Figure 66

<b>Step</b>
Enable the Show Fusion ROI check box in the functions area. A frame surrounding the defined region of interest ① is displayed in each image view.

*NOTE: The region of interest can only be modified using the **Modify ROI...** function.*

## 12.4.1 Automatic Fusion

---

### General Information

When you activate automatic fusion, the software fuses the selected image sets together based on anatomical structures common to both image sets.

The software shifts and rotates the image set until it best fits to the alignment image set (**First Image Set** that you selected in the **Fusion Creation** dialog). The similarity measure is based on mutual information and is unaffected by brightness variations in the image slices. Automatic image fusion is suitable for most arbitrary image modality combinations.

---

### How to Achieve Optimal Results

The best fusion results are achieved by:

- Fusing together images with different modalities
  - Fusing data sets with different contrast, such as MR T1 and T2 weighted images
- 

### How to Activate the Fusion

Steps	
1.	Before starting an automatic fusion, define the region where you need the highest fusion accuracy using the <b>Modify ROI...</b> function.
2.	Click <b>Auto Fusion</b> to activate automatic image fusion. The software now conducts the image fusion.

---

### How to Reset a Fusion

Step
If you have fused images, and would like to set the images back to the initial scanner coordinate system, click <b>Reset</b> .

---

### Redoing an Automatic Fusion



**If the results of a performed automatic fusion are unsatisfactory, you should return to the **Modify ROI...** function and make sure to adjust the fusion area to include all relevant structures for the treatment.**

*NOTE: Automatic fusion results can also be improved by first manually fusing images using coarse adjustments.*

## 12.4.2 Frame of Reference Fusion

### General Information

If image pairs are acquired during the same session, during data transfer, the software recognizes that these image sets share the same coordinate system generated by the scanner, based on the DICOM tag "Frame of Reference" (FoR).

Once **iPlan** has loaded such data, the image set is temporarily fused.

### Recognizing Frame of Reference Image Pairs

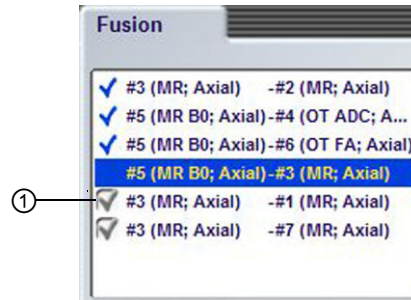

Figure 67

Image pairs that have been fused by frame of reference are shown in the list view of the functions area with the check box ticked in gray ①.

This indicates that the images are aligned but the accuracy has not been confirmed. To use these image sets, you must confirm the fusion.

### How to Confirm a Frame of Reference Fusion

Steps	
1.	Verify the accuracy of the fusion using the spyglass in the upper left image view (see page 161).
2.	If the accuracy is sufficient, click on the gray check mark to verify the fusion. The check mark is displayed in blue indicating that the fusion has been confirmed.



**Before leaving the Image Fusion planning task, make sure to verify the frame of reference fusion. Otherwise the image pairs will not be shown fused in subsequent planning steps.**

### 12.4.3 Fusion by Volumetric Information

---

#### General Information

If image pairs have identical volume parameters (scan date, pixel size, matrix size, slice number, slice position, etc.), the image fusion assumes that these image sets were acquired during the same session and thus share the same coordinate system.

This type of image fusion is necessary for post-processed images where one image set does not contain anatomical landmarks, but has the same size and position as the other image set, and the DICOM "Frame of Reference" tag information is missing.

Once **iPlan** has loaded such data, the image sets are temporarily fused. The fusion must then be confirmed.

---

#### Recognizing Identical Volume Parameters

In order to recognize the image pairs as having identical volume parameters, the following settings are verified by **iPlan** and must be identical in each image set:

- Scan date
- Number of slices
- Matrix size
- Pixel size
- Orientation
- Slice distance

*NOTE: Volumetric image fusion is only relevant if one data set contains no visible anatomical structures and must therefore be fused with other data. In usual cases where both image series have enough anatomical landmarks there are no such restrictions regarding the scan date, number of slices, matrix and pixel size, orientation and slice distance.*

---

#### Recognizing and Confirming Volumetric Fusion Pairs

Handling volumetric fusion pairs is the same as described for frame of reference fusion pairs. For information on recognizing and confirming these fusion pairs, see page 156.



**Before leaving the Image Fusion planning task, make sure to verify the volumetric fusion. Otherwise the image pairs will not be shown fused in subsequent planning steps.**

## 12.4.4 Manual Fusion

### General Information

The manual fusion functions (**Coarse** and **Fine**) allow you to perform an image fusion by aligning one image set to the other using the mouse pointer.

### How to Fuse Images by Coarse Adjustments

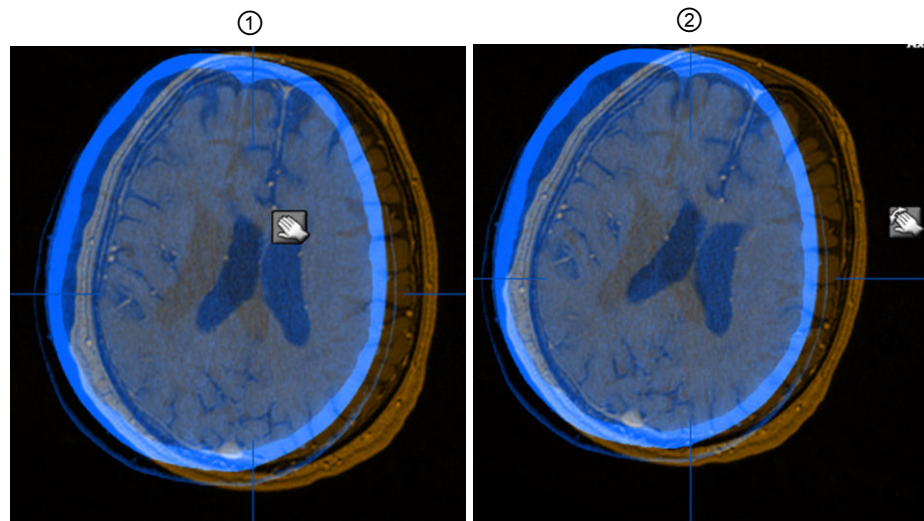

Figure 68

Steps	
1.	In the <b>Manual Fusion</b> section of the functions area, click <b>Coarse</b> .
2.	To match the images, position the amber image over the blue image as follows: <ul style="list-style-type: none"> <li>• To move the image up, down, left or right, place the mouse pointer in the center of the image view and drag with the hand symbol ① until the amber image is appropriately positioned.</li> <li>• To rotate the image, place the mouse pointer at the edge of the image view and drag with the arrow hand symbol ② until the amber image is appropriately positioned.</li> </ul>

**How to Fuse Images by Fine Adjustments**

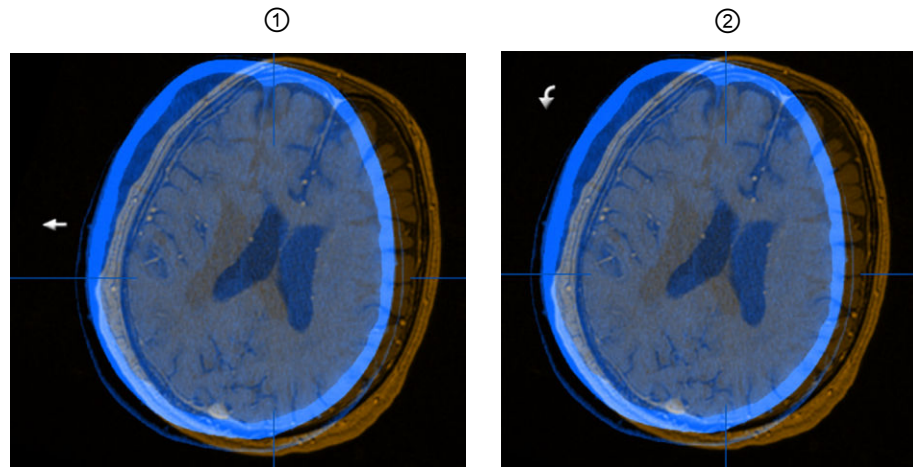

Figure 69

<b>Steps</b>	
1.	In the <b>Manual Fusion</b> section of the <b>Functions</b> area, click <b>Fine</b> .
2.	Place the mouse pointer at the border of the image until the mouse pointer is displayed as an arrow.
3.	<p>To match the images, position the amber image over the blue image as follows:</p> <ul style="list-style-type: none"> <li>• To move the image up, down, left or right, place the mouse pointer at the edge of the image view (top, bottom, left or right) and click with the arrow symbol ① until the amber image is appropriately positioned.</li> <li>• To rotate the image, place the mouse pointer at the corner-edge of the image view and click with the curved arrow symbol ② until the amber image is appropriately positioned.</li> </ul>

## 12.4.5 Registration Points Fusion

---

### General Information

If registration points are defined (see page 137), you can conduct an image fusion based on these registration points. The registration points can be anatomical landmarks or MR or CT fiducials.

---

### Before You Begin

To use this function, you must first set at least four corresponding marker pairs in each image set to be fused (see page 137).

---

### How to Activate Registration Points Fusion

Step
Click <b>Fuse Points</b> . The software conducts an image fusion based on the registration points.

---

### Alternative Registration Point Fusion

During registration points fusion, the software calculates all possible registration point fusions and automatically displays the best result.

You can display the alternative fusion results that were calculated by clicking Alternatives.

---

### Verifying the Fusion



**Before leaving the Image Fusion planning task, make sure to verify the registration points fusion, and correct manually if necessary**



# 12.5 Fusion Accuracy

## Verifying Fusion

### General Information

Once you have fused image sets, you can use the spyglass view to visually verify the accuracy of the image fusion. This allows you to, e.g., view the shape or size of a tumor in two image sets at the same time.



**Once image fusion has been completed, you should verify the results of the fusion to ensure the images have been correctly correlated.**

### Spyglass View

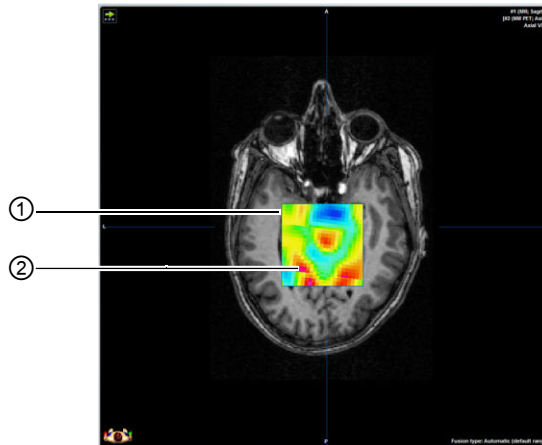

Figure 70

No.	Explanation
①	The spyglass superimposes the second (amber) image set in a frame over the first (blue) image set
②	The alignment set is shown inside the frame

### How to Verify Fusion

Steps	
1.	Place your mouse on the spyglass frame and position it over the area to be verified.
2.	Verify the fusion by dragging the spyglass area over important anatomical landmarks and comparing the two image sets at the edges of the frame.

### Verification Using Composing Options



You can also use the **Composing Options** button in the image views to verify the fusion. See page 79 for details.

### Correcting a Fusion

If the results of an **Automatic Fusion** or **Registration Points Fusion** are unsatisfactory, you can correct the fusion manually by:

1. Adjusting the image set using the **Coarse** and **Fine** functions
2. Adjusting the fusion region (**Modify ROI...**)



**In order to store the fusion region, you must save the plan before exiting Image Fusion. This information is not automatically saved when you switch tasks.**

---

### Changing an Image Fusion

Changes to an existing image fusion may lead to changes in the treatment plan. Make sure to review the treatment plan before accepting a new fusion.

# 13 OBJECT CREATION

## 13.1 Introduction

### Overview

---

#### General Information

In the **Object Creation** planning task, you can outline structures of interest in the image set. This task allows you to clearly mark the position of a tumor, for example, or outline other anatomical structures for better orientation in the image set.

---

#### General Object Creation Workflow

Workflow	
1.	Add an object to the list in the functions area (see page 165).
2.	<p>Select an object from the list, and create the object (outline the structure) in the image set. The following methods are available for creating objects:</p> <ul style="list-style-type: none"> <li>• Manual segmentation using the <b>Brush</b> function (see page 168)</li> <li>• Semi-automatic segmentation using the <b>SmartBrush</b> (see page 171) or <b>SeedBrush</b> (see page 172)</li> <li>• <b>Auto Segmentation</b> based on anatomical structures included in an atlas contained in <b>iPlan</b> (cortex, ventricles, thalamus, etc.) (see page 174)</li> <li>• <b>Auto Segmentation</b> using band thresholding to define structures unique to the patient's anatomy (see page 177)</li> </ul>
3.	If required, prepare the created objects for export (see page 196).

## 13.1.1 Object Creation Functions

### Main Screen

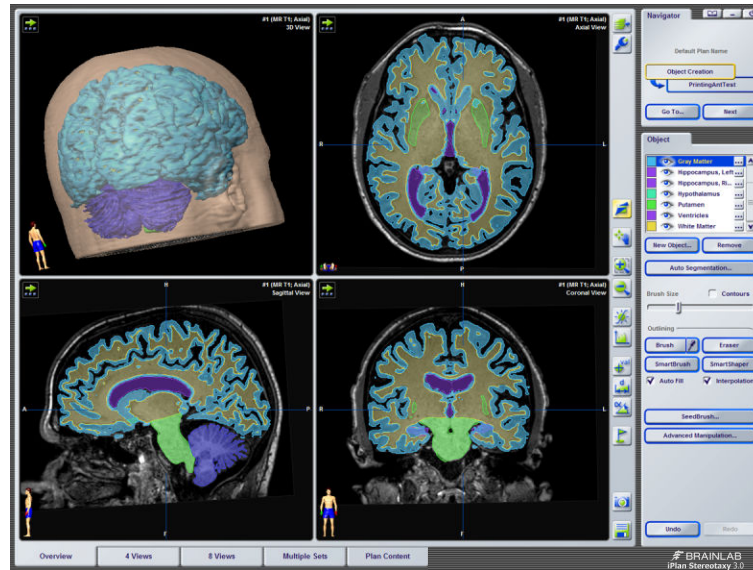

Figure 71

### Functions Overview

Function	Explanation	See
List box	Lists objects that you have added. From here you can modify the visibility, color and properties of the objects.	Page 192
New Object...	Create an object in the image set	Page 165
Remove	Delete an object from the image set	Page 195
Auto Segmentation...	Depending on the selected data set and the object to be segmented, this function allows you to either: <ul style="list-style-type: none"> <li>Segment objects within a defined region using threshold settings or,</li> <li>Activate an automatic segmentation based on the anatomical atlas</li> </ul>	Page 174
Brush Size	Adjust the brush size for the <b>Brush</b> function	Page 168
Contours	Show object as contour only	Page 194
Brush	Manually create objects with a brush	Page 168
Eraser	Delete areas of outlined objects	Page 195
SmartBrush	Create objects based on regions of similar gray value	Page 171
SmartShaper	Manually morph a selected object	Page 184
Auto Fill	The object is automatically filled in with color	Page 194
Interpolation	The object shape will be interpolated between outlined slices	Page 168
Seedbrush...	Create objects based on regions of similar gray value by including and excluding particular areas in the image	Page 172
Advanced Manipulation...	Create new objects which are morphed from objects that you have already created	Page 185

## 13.2 Adding Objects

### Adding Single Objects

#### General Information

Before you can create an object, you must add an object to the list in the functions area. When adding a single object, you can select a structure that is included in an atlas data set contained in **iPlan** (see page 174), or select a standard anatomical structure.

#### Single Object Tab

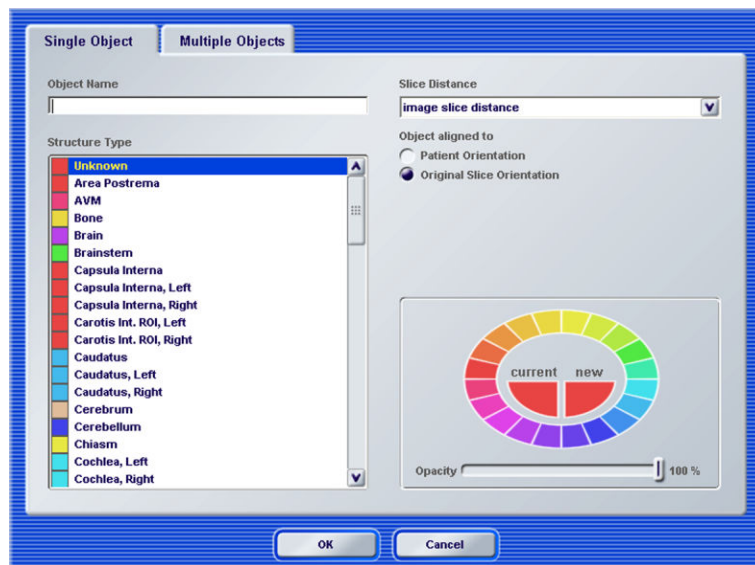

Figure 72

#### How to Add Single Objects

Steps	
1.	<p>Click <b>New Object...</b> in the functions area.</p> <ul style="list-style-type: none"> <li>• In the <b>Single Object</b> tab, enter a name for the object in the <b>Name</b> field, or</li> <li>• Select an object from the <b>Structure</b> list. If the object you select from the list is included in the atlas data set contained within the software, you will be able to perform an automatic atlas-based segmentation.</li> </ul> <p><i>NOTE: By entering the first few letters of a structure name, the structure list sorts with the best matching entries at top. Use the down arrow on your keyboard to select the structure.</i></p>
3.	<p>From the <b>Slice Distance</b> drop-down list, select the desired distance between image slices. You can use this to set the object resolution, e.g., so that the object will have a higher resolution than the original image set.</p> <p>The slice distance that you select here will correspond to the image set in which you first start to outline the object.</p> <p><i>NOTE: Generally the default setting of <b>image slice distance</b> is sufficient (see page 180).</i></p>

<b>Steps</b>	
4.	Select the object alignment: <b>Patient Orientation</b> or <b>Original Slice Orientation</b> . The object alignment that you select here will correspond to the image set in which you first start to outline the object. <i>NOTE: Generally the default setting of <b>Original Slice Orientation</b> is sufficient unless you would like to outline the object in a custom defined orientation.</i>
5.	Select a color for the object. Use the slider bar to adjust opacity of the object in the image views.
6.	Click <b>OK</b> to confirm your settings and to add the new object to the list in the functions area. You can now create the object in the image views (see page 168).

## 13.2.1 Adding Multiple Objects

### General Information

In the **Multiple Objects** tab, you can select multiple objects, which are contained within a treatment template. You can select, e.g., a cranial treatment template containing the most relevant cranial structures.

If you subsequently perform automatic segmentation, **iPlan** segments the structures in the patient data set based on the same structures contained in an atlas data set (see page 174).

### How to Add Multiple Objects

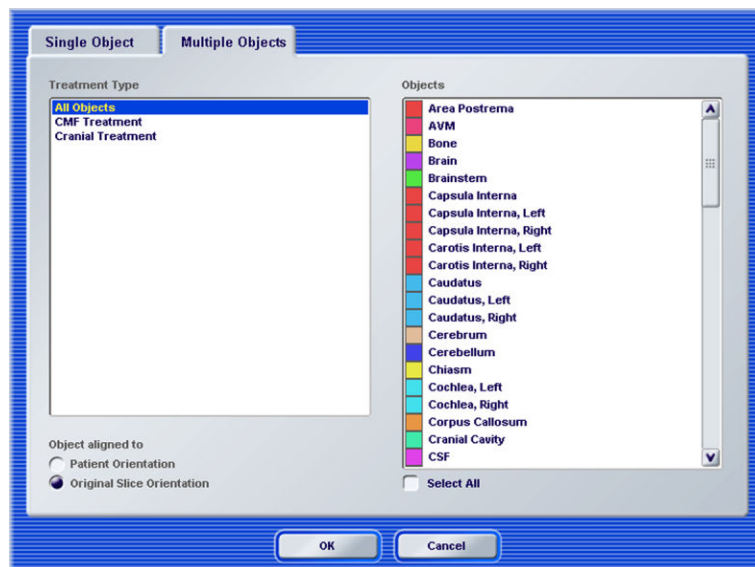

Figure 73

Steps	
1.	Click <b>New Object...</b> in the functions area.
2.	Select the treatment template from the <b>Treatment Type</b> list.
3.	In the <b>Multiple Objects</b> tab, select the objects from the <b>Objects</b> list, or click <b>Select All</b> to include all objects.
	Select the object alignment: <b>Patient Orientation</b> or <b>Original Slice Orientation</b> .
4.	<i>NOTE: Generally the default setting of <b>Original Slice Orientation</b> is sufficient unless you would like to outline the object in a custom defined orientation.</i>
5.	Click <b>OK</b> to confirm your settings and to add the new objects to the list in the functions area. You can now create the objects in the image views (see from page 168).

*NOTE: In the **Multiple Objects** tab, the slice distance is set in most cases to a default of the image slice distance. Only fine structures, such as nerves, are assigned a smaller slice distance. You can view the default slice distance value for individual structures in the **Single Object** tab (see page 193).*

## 13.3 Creating Objects

### Creating Objects Using the Brush

#### Understanding Object Interpolation

If the **Interpolation** check box in the functions area is activated, voxel information added to two non-adjacent and visible slices using the **Brush** function is interpolated between the two slices.

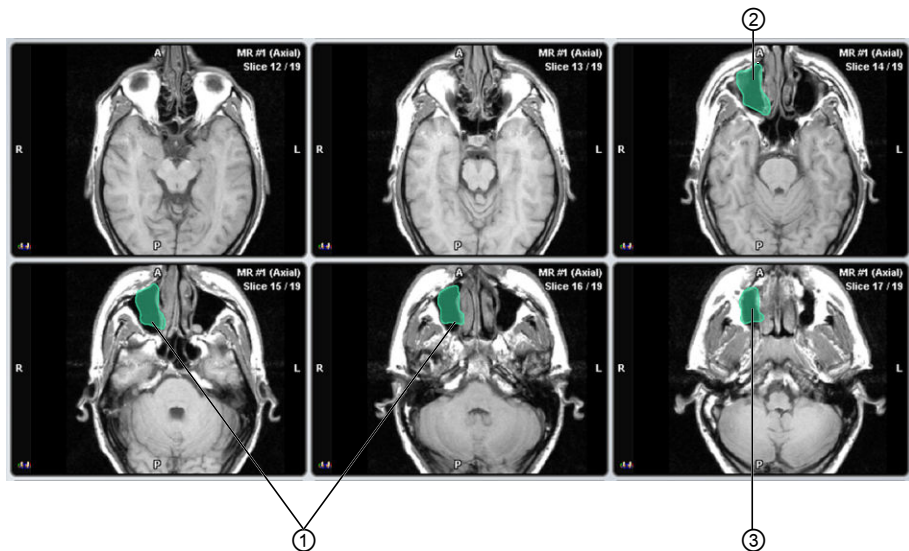

Figure 74

No.	Component
①	Interpolated information
②	Start slice
③	End slice

Interpolation will occur only in the view in which you started to outline the object. If you switch e.g., from an axial to a sagittal view, interpolation will be deactivated.

*NOTE: Creating objects in reconstructed views (containing images that have been reconstructed from original image slices) differs from creating objects in original slices. In reconstructed views, interpolated images are used, which may not show all details as expected (e.g., borders may be blurred).*

*NOTE: Interpolation works best when overlap exists between the outlined slices (see page 168).*

#### How to Create Objects

Steps	
1.	Select an object from the list in the functions area.
2.	Click <b>Brush</b> .
3.	Use the <b>Brush Size</b> slider bar to define the size of the brush. <i>NOTE: To see the approximate brush size, move the mouse into the planning area.</i>
4.	Use the mouse pointer to outline the object in the image slice.



Steps	
	Click in another image slice, and outline the object in the second slice.
5.	The software uses interpolation to show the objects in the other image slices in the view tab, and to create a 3D object in 3D views. Small and/or thin objects should be created with fine slice resolution (see page 180).

**Object in the Image Views**

The image below displays an object ① created using the **Brush** function.



Figure 75



Verify in the Overview tab that the object generated by the Brush function is correct.

**How to Use the Pipette**

The pipette function allows you to create or fine-tune an object using a defined interval of gray values.

Steps	
1.	Use the <b>Brush Size</b> slider bar to define the size of the brush.
2.	<div style="display: flex; align-items: center;">  <div style="margin-left: 10px;"> <p>Click the pipette icon ① to activate it, and then click directly in the view.</p> <p>The pixel values within the initial brush circle (as defined by the brush size) are used to define an interval of valid pixel values used during outlining.</p> </div> </div>
3.	Use the <b>Brush</b> to create the object. As you drag the <b>Brush</b> , only those pixels with values within the defined interval will be outlined.

### Tips for Creating Thin Objects

It is recommended to create thin and/or small objects in the **4 Views** or **8 Views** tab, in which you can outline the object in numerous consecutive slices, and review the 3D object in the **Overview** tab.

You can then correct the object as needed in the **Overview** or **4 Views** tabs.

*NOTE: Generally, thin and/or small objects in the 3D view may not be accurately displayed.*

### 13.3.1 Creating Objects Using the SmartBrush

#### General Information

**SmartBrush** is an image segmentation tool that offers advanced outlining functions to help you e.g., distinguish healthy tissue from tumors. When you select an area to outline, the software automatically fills in regions of gray value similar to the selected area.

*NOTE: As with the **Brush** function, **SmartBrush** uses automatic interpolation when creating objects (see page 168).*

#### How to Create Objects

Steps	
1.	Select an object from the list in the functions area.
2.	Click <b>SmartBrush</b> .
3.	Zoom to the region of interest in order to reduce the image information used for the algorithm.
4.	Use the <b>Brush Size</b> slider bar to define the size of the brush. To see the approximate size of the brush, move the mouse into the planning area. <i>NOTE: <b>SmartBrush</b> will run more efficiently with a smaller brush size.</i>
5.	Click in the region to be outlined. The shape of the object is determined by the brush size that you defined in the previous step.
6.	Hold down the left mouse button and drag the mouse over the areas to be segmented. The region that is outlined is driven by thresholding in the image. The threshold interval increases with the dragging distance.
7.	If needed, correct the edges of the outline using the Brush (see page 168) and Eraser (see page 195).
8.	Click in another image slice, and use <b>SmartBrush</b> to segment the object in the second slice. The software uses interpolation to show the objects in the other image slices in the view tab, and to create a 3D object in 3D views. <i>NOTE: Small and/or thin objects should be created with fine slice resolution (see page 180).</i>



Verify in the Overview tab that the object generated by the SmartBrush function is correct.

### 13.3.2 Creating Objects Using the SeedBrush

#### General Information

**SeedBrush** is an image segmentation tool, which like the **SmartBrush**, segments areas of similar gray value in a selected region. Once you have segmented a region using the **SeedBrush**, you can then apply the segmentation to additional image slices.

*NOTE: The segmentation area within the data set is limited to the area displayed in the individual views (depending on the zoom factor) and the number of displayed image views (for example, in the **4 Views** or **8 Views** tabs).*

#### Before You Begin

Before segmenting using **SeedBrush**, it may be helpful to optimize the windowing if the gray level of the area to be segmented is the same as that of the rest of the scan image, or if poor quality scan images are used.

Steps	
1.	 Open the <b>SeedBrush</b> dialog (see below) and click the <b>Windowing</b> button in the dialog.
2.	Adjust image brightness and contrast so that the areas you wish to outline are clearly discernible (see page 172).

#### How to Activate Seedbrush





Figure 76

Steps	
1.	Select an object from the list in the functions area.
2.	Click <b>SeedBrush...</b> to open the <b>SeedBrush</b> dialog.

---



## How to Create Objects

Steps	
1.	 Click <b>Zoom</b> and zoom in on the area to be segmented.
2.	 Click <b>Pan and Recenter</b> to center the image.
3.	Use the <b>Brush Size</b> slider bar to define the size of the brush. To see the approximate size of the brush, move the mouse into the planning area.
4.	To mark areas to be included in the segmentation, click Include and: <ul style="list-style-type: none"> <li>• Hold the left mouse button down and move the mouse pointer across the section of the image you would like to include, or</li> <li>• Click the image at the point.</li> </ul>
5.	To mark sections which should not be outlined, click Exclude and: <ul style="list-style-type: none"> <li>• Hold the left mouse button down and move the mouse pointer across the section of the image you would like to exclude, or</li> <li>• Click the image at the point.</li> </ul>
6.	Click Apply. Regions of similar gray value to the selected area are automatically filled in and the segmented object is displayed in the image views.
7.	If needed, correct the edges of the outline using the Brush (see page 168) and Eraser (see page 195).

*NOTE: The **SeedBrush** results can be improved by successively setting more “seeds” using the above steps.*

---

## How to Outline the Same Object in Adjacent Slices

Steps	
1.	  Use the <b>Browse Slices</b> buttons in the toolbar to select the next four slices.
2.	Click Apply to copy the outline to the displayed slices.
3.	To outline other regions of interest, repeat the Include, Exclude and Apply procedure described above as often as necessary until the desired result is achieved.

---

## Verifying the Object



Verify in the Overview tab that the object generated by the SeedBrush function is correct.

## 13.4 Creating Objects Using Automatic Segmentation

### Automatic Segmentation Using the Atlas

---

#### General Information

**Auto Segmentation** uses a knowledge-based segmentation approach that identifies organs and other structures in the human body by comparing the patient's data set with an atlas data set (contained in **iPlan**), in which the structures are already outlined.

Using the atlas, the software finds the point-to-point correspondence of the patient's data set and the atlas data and transfers all outlined structures of the atlas into the patient data.

The link between the patient's data set and the atlas data is not a rigid transformation that recognizes the differences in shape and size of the anatomical structures. Rather, the atlas set is transformed elastically in such a way that the similarity of the data sets increases.

---

#### Requirements

**Auto Segmentation** using the atlas can be applied if:

- You are working with MR and/or CT anatomical images. The following submodalities are supported: MR T1 with and without contrast agent, and MR T2 weighted.
- You select an object or multiple objects for segmentation which are included in the atlas contained in the software.

*NOTE: In **iPlan Stereotaxy**, the cerebrum, gray matter and white matter are available for atlas-based **Auto Segmentation**.*

*NOTE: Best results are obtained using high quality images (those that are high resolution, have high tissue contrast, and large volumes).*

---

#### MR Image Sets: Submodality

For atlas-based **Auto Segmentation** of MR image sets, different atlases are used depending on the image set submodality. By default, the software automatically defines the submodality during segmentation. If segmentation results are not satisfactory, you can review the submodality, and if necessary, manually select a different submodality in the **Plan Content** tab (see page 88), and repeat **Auto Segmentation**.

---

#### CT Image Sets



The atlas-based **Auto Segmentation** of CT image sets uses the calibrated Hounsfield scale. Therefore, it may deliver poor results for uncalibrated CT image sets or modalities such as DVT/Cone Beam/XA.

---

#### Outlining Tumors

If the brain contains a tumor, it is recommended to outline this region first, i.e., create a tumor object before applying **Auto Segmentation**. By first outlining the tumor object, any later automatically segmented structures will subtract the tumor region. Tissue mis-classification of the resulting segmented structure will be reduced.

If you do not outline the tumor before applying **Auto Segmentation**, the tumor will be automatically ignored during the segmentation. Keep this in mind if you intend to perform a volumetric analysis.

*NOTE: Any errors that occur while outlining a tumor will be propagated accordingly into the auto-segmented objects.*

---

**Atlas Structures**

The following structures are included in the atlas contained in the software. Availability of structures depends on the selected treatment template (see page 167).

Structures in the MR atlas	Structures in the CT atlas
Brain:	Carotis int. ROI, left
Cerebrum	Carotis int. ROI, right
Gray matter	Ethmoid bone
White matter	Frontal bone
Cerebellum	Mandible
Brainstem	Mandible Body, Left
• Medulla oblongata	Mandible Body, Right
Hypothalamus	Ramus Mandible, Left
• Pineal gland	Ramus Mandible, Right
• Pituitary gland	Maxilla
Ventricles	Maxilla, Left
CSF	Maxilla, Right
Cranial cavity	Le Fort I Template
Hippocampus, left; Hippocampus, right	Le Fort I Template, Left
Thalamus, left; Thalamus, right	Le Fort I Template, Right
Caudatus, left; Caudatus, right	Le Fort III Template
Putamen, left; Putamen, right	Le Fort III-I Template
Capsula interna, left; Capsula interna, right	Nasal bone
Eye, left; Eye, right	Occipital bone
Optic apparatus:	Orbit, left
• Optic nerve, left; Optic nerve, right	Orbit, right
• Chiasm	Orbital Cavity, Left
• Optic tract, left; Optic tract, right	Orbital Cavity, Right
Lens, left; Lens, right	Parietal bone, left
Cochlea, left; Cochlea, right	Parietal bone, right
Inner ear, left; Inner ear, right	Sphenoid bone
	Temporal bone, left
	Temporal bone, right
	Zygomatic bone, left
	Zygomatic bone, right

## How to Apply and Verify Segmentation

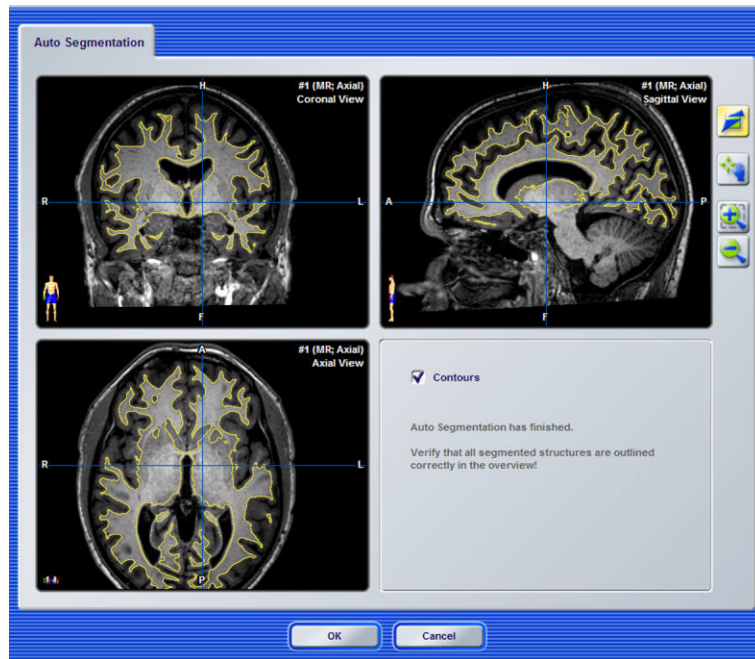

Figure 77

Steps	
1.	Select an atlas object from the list in the functions area.
2.	Click <b>Auto Segmentation...</b> to open the <b>Auto Segmentation</b> dialog (shown above). The software activates the automatic segmentation and tracks the progress.
3.	Once the procedure is complete, verify that all objects are correctly segmented in the image views.
4.	Click <b>OK</b> to confirm the segmentation and close the <b>Auto Segmentation</b> dialog. The segmented objects are now displayed in all image views in the planning area.



**Segmentation using atlas-based segmentation may not find the correct shape of a particular structure. For this reason, all objects that have been automatically segmented must be verified by the user.**



### 13.4.1 Automatic Segmentation with Band Thresholding (Using a Region of Interest)

#### General Information

The **Auto Segmentation** function also allows you to define structures that are unique to the patient's anatomy and can be easily distinguished in the selected image set. This segmentation procedure can be performed for objects that are not included in the atlas.

#### Band Thresholding Dialog

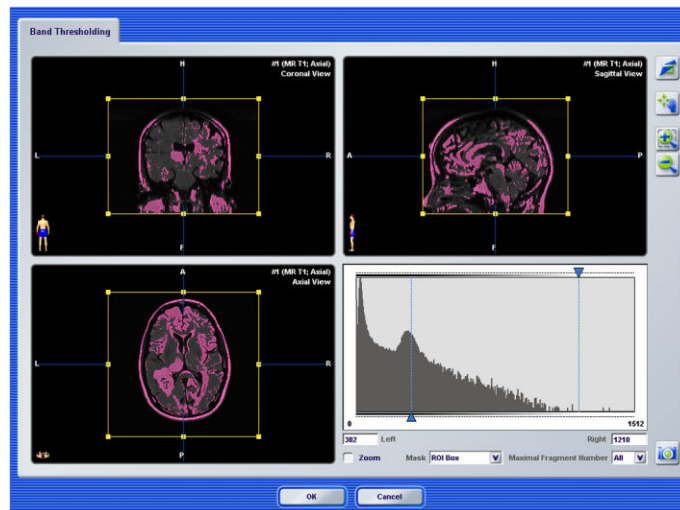

Figure 78

#### How to Apply Band Thresholding

Steps	
1.	Select a non-atlas object from the list in the functions area.
2.	Click <b>Auto Segmentation...</b> to open the <b>Band Thresholding</b> dialog.
3.	You can now define a three-dimensional region of interest (ROI) in the image view in order to adjust the image contrast within this area. To define the ROI shape, select <b>ROI Box</b> or <b>ROI Ellipsoid</b> from the <b>Mask</b> drop-down list.
4.	Use the mouse pointer to position the frame in the axial, coronal or sagittal view to surround the region that is to be segmented.
5.	From the <b>Maximal Fragment Number</b> drop-down list, select the number of fragments to be detected and segmented. For example, if you select one fragment, then the largest connected area will be segmented. The preview does not take into account the selected fragment number. Once you confirm the settings with <b>OK</b> , the fragment number is considered in the calculation. <i>NOTE: The <b>Maximal Fragment Number</b> can be used to eliminate small artifacts in thresholded objects and reduce the amount of memory.</i>
6.	Define the gray values in the mapping function (bottom right) view by: <ul style="list-style-type: none"> <li>• Entering the <b>Right</b> and <b>Left</b> values directly in the fields provided, or</li> <li>• Using the mouse pointer to adjust the left value and/or right value sliders until the required values are shown in the corresponding fields.</li> </ul>
7.	To more accurately define the windowing, enable the <b>Zoom</b> check box to zoom in on the area between the left and right threshold.

Steps	
8.	Click <b>OK</b> to confirm your settings and activate the segmentation. The segmented objects are now displayed in all image views in the planning area.

**Example: How to Perform Vessel Segmentation**

Certain objects are assigned default thresholds for segmentation, as is the case for vessel segmentation. For MR images, a minimum value of 1433, and a maximum value of 2252 is applied.

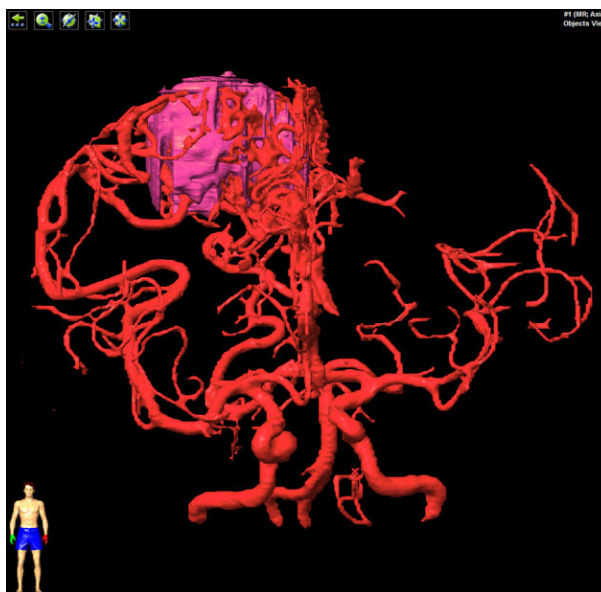

Figure 79

Steps	
1.	From the <b>Mask</b> drop-down list, select <b>Ellipsoid ROI</b> . Make sure that the ROI contains the vessels that you intend to segment.
2.	Verify that the default threshold values highlight the vessels. Otherwise manually adjust the values.
3.	Select the appropriate <b>Maximal Fragment Number</b> , depending on length and width of the vessels you intend to segment.
4.	Click <b>OK</b> .



**All vessels that have been automatically segmented must be verified by the user.**

## 13.4.2 Automatic Segmentation with Band Thresholding (Using a Mask Object)

### General Information

In the **Band Thresholding** dialog, you can also perform a segmentation within an area defined by a mask object (another segmented object).

You must first create a mask object that defines the area for the segmentation. You can then segment a new object within this defined region.

### How to Add the Objects

Steps	
1.	Use the <b>New Object...</b> function to add an object (using the <b>Single Object</b> tab) to the list in the functions area. This is the mask object.
2.	To broadly define the area to be segmented, select the object from the list in the functions area and perform segmentation using the <b>Brush</b> (see page 168) or <b>SmartShaper</b> (see page 184) functions.
3.	Use the <b>New Object...</b> function to add another empty object to the list in the functions area.

### How to Activate Band Thresholding

Steps	
1.	Select the empty object you have just added in the functions area and click <b>Auto Segmentation...</b> to open the <b>Band Thresholding</b> dialog.
2.	From the <b>Mask</b> drop-down list, select the mask object you created.
3.	Define the gray values in the mapping function (bottom right) view by: <ul style="list-style-type: none"> <li>• Entering the <b>Right</b> and <b>Left</b> values directly in the fields provided, or</li> <li>• Using the mouse pointer to adjust the left value and/or right value sliders until the required values are shown in the corresponding fields.</li> </ul>
4.	In order to more accurately define the windowing, enable the <b>Zoom</b> check box to zoom in on the area between the left and right threshold.
5.	Click <b>OK</b> to confirm your settings and activate the segmentation. The segmented objects are now displayed in all image views in the planning area.

### Verifying Segmentation



Segmentation using band thresholding may not find the correct shape of a particular structure. For this reason, all objects that have been automatically segmented must be verified by the user.

# 13.5 Creating High Resolution Objects

## Overview

### General Information

**iPlan** allows you to create objects with a higher resolution than the resolution of the selected image set (i.e., so that the object slice distance is finer than the image slice distance). This facilitates the outlining of small and/or thin objects, particularly in reconstruction views that are perpendicular to the original image slices.

Creating high resolution objects can be useful, for example:

- For accurate stereotactic planning that requires that objects are created in reconstruction views
- For volumetric analysis where accurate comparison of different objects is important (see page 182)
- For radio/neuro-surgery where a precise outline of the clinical target relative to risk organs is required

### How to Create High Resolution Objects

You must first define certain settings in the **Single Object** tab that opens when you click **New Object...** in the functions area. These settings are described on the following pages.

Once you define the settings you can create an object using the previously described functions (**Brush**, **SmartBrush**, **Auto Segmentation**, etc.).

### Screen Layout

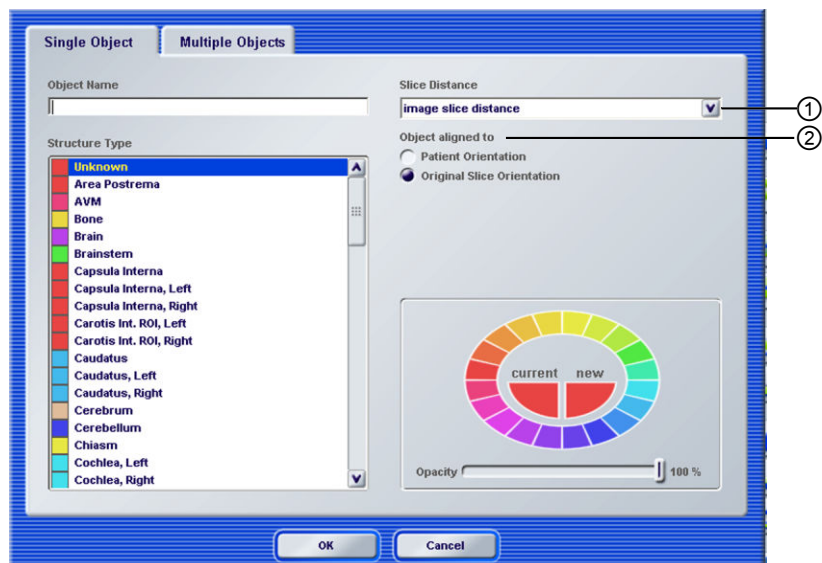

Figure 80

**Defining Settings for High Resolution Objects**

No.	Setting	Explanation
①	Slice Distance	<p>Select the desired distance between object slices (e.g., 1 mm, 2 mm). You can use this to set the object resolution, so that the object will have a higher resolution than the original image set distance.</p> <p><i>NOTE: The selected value is approximate. The software chooses the closest value that divides the original image slice distance into equally spaced sub-slices. The resulting slice distance(s) will not differ more than a factor of 1.7 from the one selected. Additionally, if the image set slice distance varies over the image slices, then the object slice distances will also vary. In this case, the range (minimum and maximum values) of slice distances will be displayed.</i></p> <p><i>NOTE: To see slice distance values for image sets, refer to the <b>Plan Content</b> tab.</i></p>
②	Object aligned to	<p>Select from the following options:</p> <ul style="list-style-type: none"> <li>• <b>Patient Orientation:</b> The object slices will be aligned so that they are parallel to the standard anatomical axes of the patient. This allows outlining to be done in true axial, coronal and sagittal slices. This is true even for image sets scanned with gantry tilt, or image sets in which the coordinate system was predefined by localization or image fusion. Custom orientations are respected accordingly.</li> <li>• <b>Original Slice Orientation:</b> The object slices will be aligned with the image slices, except for additional subslices which are inserted depending on the selected slice distance (see above). Objects with original slice orientation allow you to outline and review structures in the original image slices as provided by the scanner (as long as the corresponding view orientation is used), regardless of the actual slice orientation.</li> </ul> <p><i>NOTE: Patient and slice orientation may be the same or different depending on the situation (see page 181).</i></p>

*NOTE: The slice distance and object alignment that you select in the dialog will correspond to the image set in which you first start to outline the object.*

**Objects and Orientation**

Original image slices are not aligned with patient orientation in the following cases if the image set was:

- Scanned with gantry tilt
- Fused to another image set
- Localized
- Assigned a custom orientation (see page 73)

*NOTE: If the object is not aligned with the patient or original slice orientation, the corresponding alignment is shown in **Align object to** section of the **Properties** dialog. This may be the case for objects created outside of the **Object Creation** task, or if the image set orientation was adjusted after the object was created.*

---

## Comparing Objects

The calculated values of an object, e.g., volume (shown in the **Plan Content** tab below) are based on the object resolution.

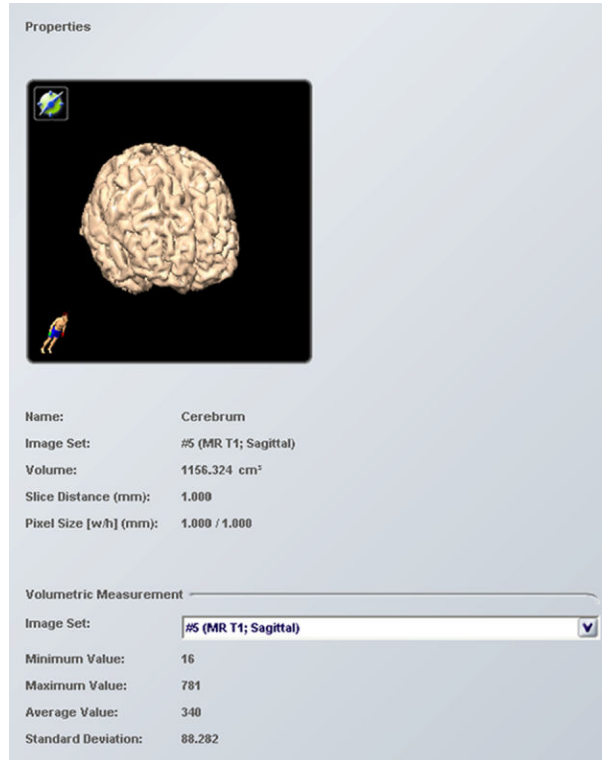

Figure 81

If you would like to compare statistics for similar objects created in two different image sets, the object resolution settings (slice distance and object orientation) should be the same for each object. Otherwise the displayed values may not be suitable for comparison.

---

## Changing the Slice Distance



**If you change the slice distance for an already created object (by opening the Properties dialog, see page 192), the object will be resampled to the new slice distance. This may cause the object shape and/or volume to change. Carefully inspect the object after making any changes.**

## 13.5.1 Verifying High Resolution Objects



### General Information

If you have created a high resolution object, you can review the object in **Fine** image views, which have a slice distance comparable to the slice distance of the selected object. In this way, you can scroll through image slices that are closer together (i.e., with a higher resolution) than in standard views.

**Fine** views are only effective if the object slice distance is smaller than the slice distance of the original image set distance.

*NOTE: Verify the correctness of high resolution objects in the **Overview** tab.*

### How to View Objects in Fine Mode

Steps	
1.	Select the object you would like to review.
2.	 In the <b>4 Views</b> or <b>8 Views</b> tab, click the <b>View Orientation</b> button to display the orientation options.
3.	 Select the orientation, <b>Axial Fine</b> , <b>Coronal Fine</b> , or <b>Sagittal Fine</b> . The view is updated accordingly.
4.	Scroll through the image set to view the object in each slice.

*NOTE: The slice distance in the **Fine** image views corresponds to the slice distance of the selected object. If you select a different object, the **Fine** view is then based on the newly selected object. **Fine** views are labeled as such in the upper right corner of each view.*

*NOTE: Object details that are visible in **Fine** mode may not be visible in standard views. Keep this in mind when reviewing high resolution objects.*

# 13.6 Correcting Objects

## Modifying Objects Using SmartShaper

### General Information

**SmartShaper** allows you to manually morph or reposition an already created object.

### What is SmartShaper?

**SmartShaper** is an advanced tool for deformation of anatomical objects within the patient anatomy in three dimensions. Similar to atlas-based segmentation which adapts an atlas data set to fit the patient data set, **SmartShaper** lays a grid of invisible control points over the object to be adapted. The grid of control points is then automatically adjusted using elastic deformation.

### How to Use SmartShaper

You can interactively push or pull the control points by moving the adjustable brush over the object area. As the grid is deformed, so is the corresponding object, as it is connected to the grid in all three dimensions (axial, coronal, sagittal).

You can also use **SmartShaper** outside the object in a pulling fashion. This works since the brush deforms the space where the object is embedded. A simple comparison could be drawn with an image painted on a balloon. If one pushes or pulls the balloon, the image on the balloon is squeezed or dilated accordingly.

*NOTE: **SmartShaper** is intended only for minor corrections of border areas.*

### How to Use SmartShaper

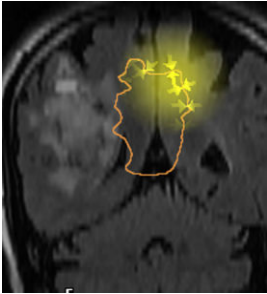
Steps	
1.	Select an object from the list in the functions area and click <b>SmartShaper</b> .
2.	<ul style="list-style-type: none"> <li>• To show the displayed objects as an outline, enable the <b>Contours</b> check box.</li> <li>• Adjust the diameter of the shaper tool using the <b>Brush Size</b> slider bar. A diameter larger than 3 mm is recommended.</li> <li>- If you use a smaller brush size, the number of grid points calculated increases, thus increasing sensitivity.</li> <li>- If you use a larger brush size, the adjustments become coarser.</li> </ul> <p><i>NOTE: <b>SmartShaper</b> may not work as intended for small brush sizes. Small changes are better done by locally applying the <b>Brush</b> and <b>Eraser</b>.</i></p>
3.	<div style="display: flex; align-items: center;">  <div style="margin-left: 20px;"> <p>To adjust the object shape, move the mouse pointer across the object to adjust its outer contour.</p> </div> </div>



Verify in the Overview tab that the object modified by the SmartShaper function is correct.



## 13.7 Advanced Object Manipulation

### Accessing

---

#### How to Access Advanced Features

Steps	
1.	Click <b>Advanced Manipulation...</b> in the functions area.
	Depending on the type of object manipulation you wish to perform, select from the following tabs:
2.	<ul style="list-style-type: none"><li>• <b>Scaling</b> (see page 186)</li><li>• <b>Logical Operations</b> (see page 188)</li><li>• <b>Splitting</b> (see page 190)</li></ul>

*NOTE: Increasing an object's resolution prior to performing an advanced manipulation could reduce the loss of information.*

---

#### Verifying Objects



**All objects that have been adjusted using the Advanced Manipulation... functions must be verified by the user.**

## 13.7.1 Scaling Objects

### General Information

In the **Scaling** dialog, you can:

- Proportionately enlarge or shrink objects that you have already created and generate a new object from the morphed object
- Create a “wall” object which is generated relative to a source object that you have already created

### Scaling Dialog

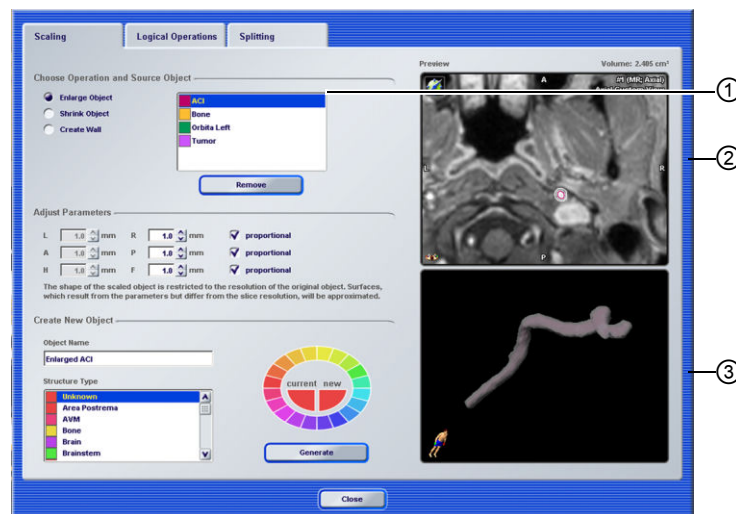

Figure 82

No.	Explanation
①	List of source objects
②	Selected source object from which the scaled object will be created
③	Preview of the scaled object based on the performed object manipulation

*NOTE: The options available in the **Scaling** dialog vary depending on whether you are shrinking or enlarging objects, or creating a wall object.*

### How to Enlarge or Shrink Objects

Steps	
1.	Select <b>Enlarge Object</b> or <b>Shrink Object</b> from the <b>Choose Operation and Source Object</b> section of the <b>Scaling</b> dialog.
2.	Select the object you wish to scale from the list of source objects.

Steps	
3.	<p>In the <b>Adjust Parameters</b> section, define the dimensions in millimeters by which the object should increase or decrease in size.</p> <p>By default, the size of the object will adjust proportionately in the left-right, anterior-posterior and head-foot directions. To deactivate this setting, click the <b>proportional</b> check box for the corresponding orientation.</p> <p><i>NOTE: If you define values in the parameters fields that vary greatly from each other and apply the <b>Shrink</b> function, the resulting object may not appear as expected. However, the object will still be correct.</i></p>
4.	<p>In the <b>Object Name</b> field, define a name for the scaled object. You can also select a predefined structure from the <b>Structure Type</b> list.</p> <p><i>NOTE: By default, the new object is named according to the name of the source object and the selected operation.</i></p>
5.	Click the desired color for the object.
6.	To preview the result of the scaling operation, click on the preview views provided to the right of the tab page.
7.	Click <b>Generate</b> to create the scaled object.
8.	<p>To confirm your settings and close this dialog, click <b>Close</b>.</p> <p>The scaled object is now shown in the list view in the <b>Functions</b> area.</p>

---

### How to Create a Wall Object

Steps	
1.	Select <b>Create Wall</b> from the <b>Choose Operation and Source Object</b> section of the <b>Scaling</b> dialog.
2.	<p>Select from the following options:</p> <ul style="list-style-type: none"> <li>• Click <b>Exterior</b> to display the wall object outside of the source object</li> <li>• Click <b>Centered</b> to display the source object boundary in the center of the new wall object</li> <li>• Click <b>Interior</b> to display the wall object inside the source object</li> </ul>
3.	From the list of source objects, select the object from which you wish to create a wall object.
4.	In the <b>Adjust Parameters</b> section, define the dimensions in millimeters for the wall object.
5.	<p>In the <b>Object Name</b> field, define a name for the wall object. You can also select a predefined structure from the <b>Structure Type</b> list.</p> <p><i>NOTE: By default, the new object is named according to the name of the source object.</i></p>
6.	Click the desired color for the object.
7.	To preview the result of the scaling operation, click on the preview views provided to the right of the tab page.
8.	Click <b>Generate</b> to create the wall object.
9.	<p>To confirm your settings and close this dialog, click <b>Close</b>.</p> <p>The wall object is now shown in the list view in the functions area.</p>

## 13.7.2 Merging Objects

### General Information

In the **Logical Operations** dialog, you can merge two objects and create a new object from the merged objects.

### Logical Operations Dialog

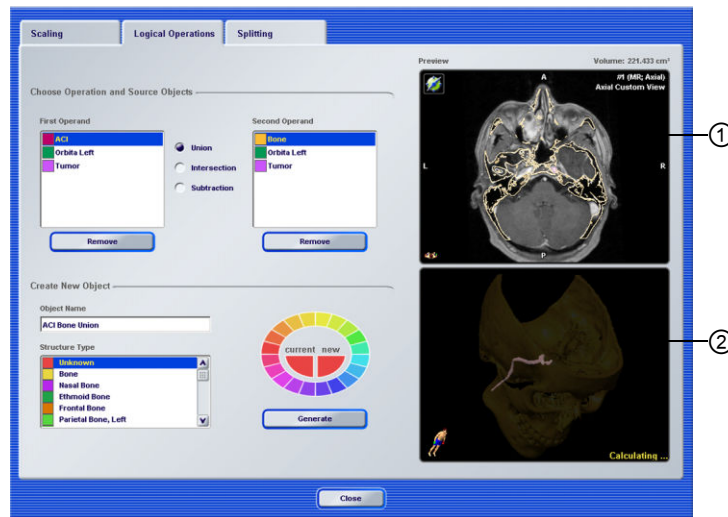

Figure 83

No.	Explanation
①	Selected source objects from which the new object will be created
②	Preview of the new object based on how the two source objects have been merged

### How to Merge Objects

Steps	
1.	From the <b>First Operand</b> and <b>Second Operand</b> fields, select the two objects on which the new object should be based.
2.	Select the desired operation from the following options: <ul style="list-style-type: none"> <li>• Click <b>Union</b> to create a new object from two merged objects</li> <li>• Click <b>Intersection</b> to create a new object from the intersection of two objects</li> <li>• Click <b>Subtraction</b> to create a new object which results from the subtraction of the second object (<b>Second Operand</b>) from the first object (<b>First Operand</b>)</li> </ul>
3.	In the <b>Object Name</b> field, define a name for the new object. You can also select a predefined structure from the <b>Structure Type</b> list. <i>NOTE: By default, the new object is named according to the selected operation.</i>
4.	Click the desired color for the object.
5.	To preview the result of the merge operation, click on the preview views provided to the right of the tab page.
6.	Click <b>Generate</b> to create the new object.
7.	To confirm your settings and close this dialog, click <b>Close</b> . The new object is now shown in the list view in the functions area.

*NOTE: **Union**, **Intersection**, and **Subtraction** results could differ from the object's original shape if they are segmented in different slice sets and/or with different resolutions.*

### 13.7.3 Splitting Objects

#### General Information

In the **Splitting** dialog, you can split an object you have created into two parts.

#### Splitting Dialog

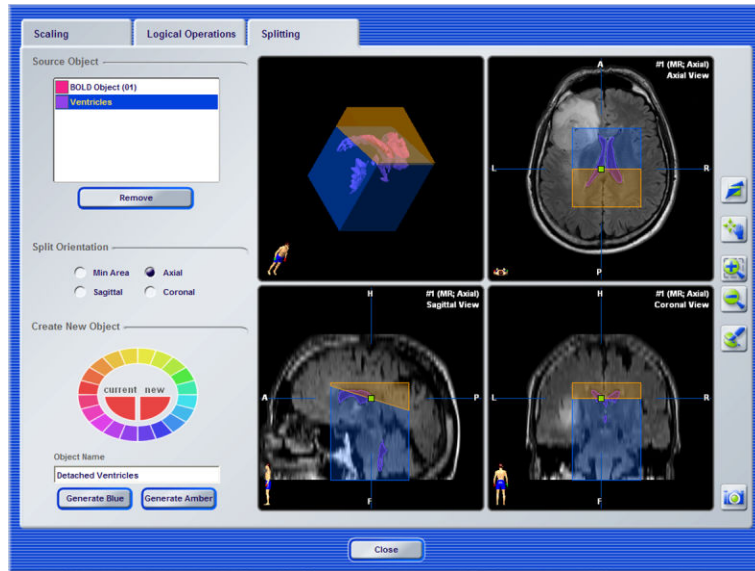

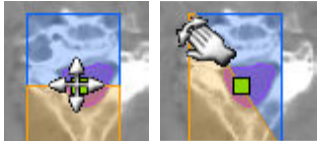

Figure 84

#### How to Split Objects

Steps	
1.	From the <b>Source Object</b> list, select the object to be split.
2.	Select the desired split orientation for the cutting plane: <ul style="list-style-type: none"> <li>• Click <b>Min Area</b> to freely define the split orientation so that the cross-section is kept to a minimum</li> <li>• Click <b>Axial</b>, <b>Coronal</b> or <b>Sagittal</b> to split the object according to the defined orientation</li> </ul>
3.	 Click the <b>Object Splitter</b> button in the toolbar in the <b>Splitting</b> tab.
4.	Click on the preferred view in the tab page.
5.	 <p>Using the mouse pointer, drag on the green square to adjust the cutting plane along the selected orientation. It is also possible to tilt the plane by moving the mouse pointer above or below the green square.</p>
6.	Verify in the views that the object is split correctly.

---

### How to Generate Split Objects

Once you are satisfied that the object has been correctly split, you can generate the two new objects indicated by the blue and amber boxes

Steps	
1.	In the <b>Object Name</b> field, define a name for the first object.
2.	Click the desired color for the object.
3.	Click <b>Generate Blue</b> or <b>Generate Amber</b> , depending on which object you wish to generate. This object is now shown in the <b>Source Object</b> list.
4.	Repeat steps 1-3 for the second object.
5.	To confirm your settings and close this dialog, click <b>Close</b> . The new objects are now shown in the list view in the functions area.

## 13.8 Object Properties

### Overview

#### General Information

Each object consists of various properties that you defined when you created the object, e.g., color, name, structure type, etc. Once you have created an object, you can view and adjust some properties as needed in the relevant **Properties** dialog. Other properties (e.g., object volume) can be viewed in the **Plan Content** tab.

*NOTE: Some objects (e.g. the **Cerebrum**) have special visualization options if you are running **Advanced 3D** (see page 93).*

#### How to Access Object Properties



To open the **Properties** dialog, click the properties icon next to the object from the list in the functions area.

#### Properties Dialog

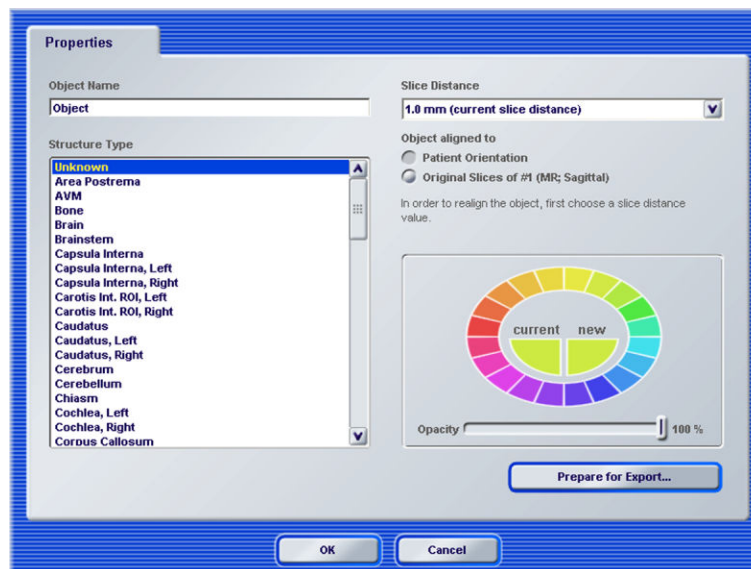

Figure 85

The following information is provided:

- Structure type (e.g., from the atlas)
- Object name
- Object slice distance and alignment: These settings allow you to create high resolution objects when a more accurate outline is required.
- Object color and opacity
- **Prepare for Export...** button to define certain settings for object export (see page 196).

These settings are described in detail from page 165.



## Object Properties in the Plan Content Tab

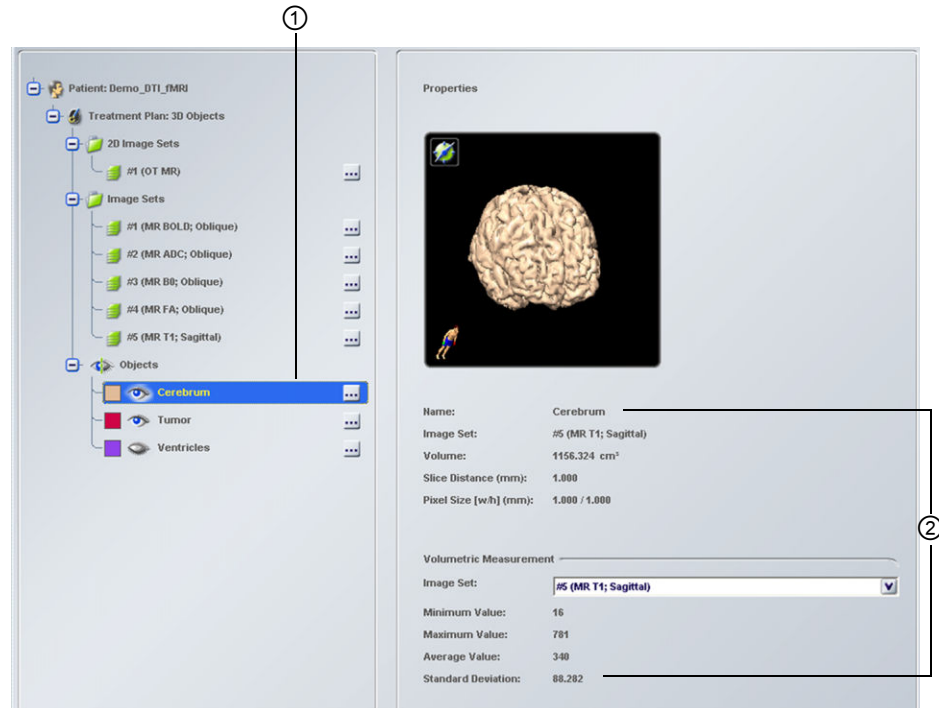

Figure 86

By selecting an object on the left side of the dialog ①, its properties are displayed on the right side of the dialog ②.

The following information is shown:

- Object name
- Image set in which the object was created
- Object volume
- Object slice distance
- Object pixel size
- Volumetric measurement information: Here you can select another image set in order to view volumetric measurement values for the object based on that image set.
- **Copy to Clipboard** button at the bottom of the **Plan Content** tab: Allows you to copy the object data to the Windows clipboard, e.g., for transfer to an external file

## Object Shape and Volume



The Volume value is calculated by iPlan based on image quality, image resolution, slice thickness, etc., and may differ from the actual volume of the outlined object.

# 13.9 Additional Functions

## Additional Object Creation Options

### How to Use the Auto Fill Function

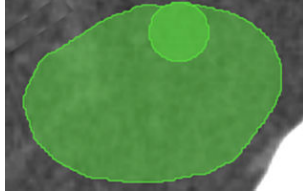
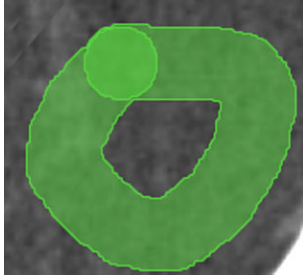
Options	
	To automatically fill in a space you enclose e.g., by creating a circle using the <b>Brush</b> , <b>SmartBrush</b> , or <b>SeedBrush</b> functions, enable the <b>Auto Fill</b> check box.
	To show the enclosed space outlined according to the brush size, disable the <b>Auto Fill</b> check box.

### How to Use the Contours Function

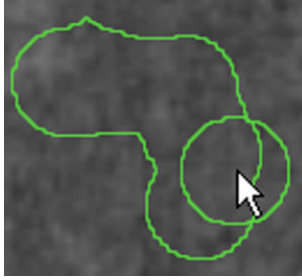
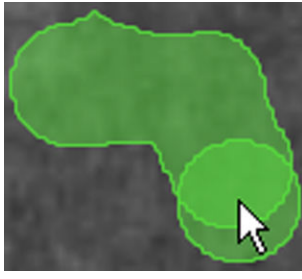
Options	
	To show both the <b>Brush/Eraser</b> tool and any created objects as outlines, enable the <b>Contours</b> check box.
	To show the <b>Brush/Eraser</b> tool and any created objects filled with the selected color, disable the <b>Contours</b> check box.

*NOTE: This function is available when using the **Brush**, **Eraser**, **SmartBrush**, and **SeedBrush**.*

---

### How to Erase Objects

The **Eraser** function allows you to manually remove information from created objects.

Steps	
1.	Click <b>Eraser</b> .
2.	 Click on the image and, holding down the left mouse button, move the mouse pointer until the required area has been deleted ①.

---

### How to Remove Objects

Steps	
1.	Select the object from the list.
2.	Click <b>Remove</b> .

## 13.10 Preparing Objects for Export

### Preparing Objects



#### General Information

Once you have completed object planning, you can prepare all objects for export. This is useful when exporting objects for navigation, or for use with e.g., **iPlan RT Image**.

This step is required if:

- The object does not have the default slice distance and/or the original slice orientation
- You intend to select another image set in which to export the object

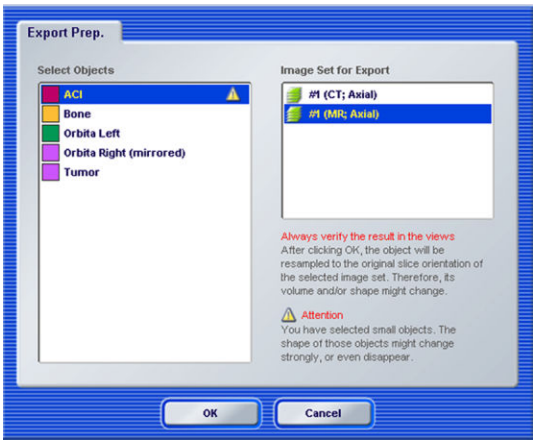
#### How to Prepare Objects for Export

Steps	
1.	 Click the properties icon next to the object from the list in the functions area.
2.	 <p style="text-align: center;">In the <b>Properties</b> dialog, click <b>Prepare for Export...</b> to open the <b>Export Prep.</b> dialog.</p>
3.	 <p>Select the objects that you would like to export to the selected image set.  <i>NOTE: This icon indicates that the corresponding object has a small volume and the object shape may significantly change during export.</i></p>
4.	Select the image set that you would like to export.
5.	Click <b>OK</b> to confirm the selection.

#### Verifying Objects



Once you confirm your selection with **OK**, the object is resampled to the original slice orientation. This may cause the objects volume and/or shape to change. Carefully inspect the object in the image views.

# 14 BOLD MRI MAPPING

## 14.1 Introduction

### Overview

---

#### What is BOLD MRI?

BOLD (blood oxygen level dependent) MRI is a technique that shows the increased blood flow in activated brain areas on MRI scans. When you move your fingers for example, there is first an increased neuronal activity and subsequently an increased blood flow in the motor area of the brain.

This flow increase exceeds the actual demand for oxygen. This results in an increase of oxygenated blood relative to de-oxygenated blood and yields a subtle change in MRI signal strength in comparison to the pre-activity state.

This small change in MRI signal can be detected using ultra-fast Echo Planar Imaging (EPI) techniques, and allows the mapping of active areas of the brain.

---

#### Reconstructing Activation Maps

The functional activity is calculated using the statistical parametric mapping approach, which is based on a General Linear Model (GLM), whereby a design matrix specifies a statistical model consisting of a set of predictors or explanatory variables.

The design matrix is an important tool for making hypotheses about expected changes of the BOLD MRI signal. Using the General Linear Model, the statistical model specified in a design matrix is compared with the measured time course at each voxel. The comparison of the model and the data is expressed as values for each voxel, which indicate how well the overall model fits to the data.

If the value of a voxel passes a statistical threshold, the respective voxel will be highlighted by appropriate color-coding. The implemented methods and algorithms are peer reviewed and published.

---

#### How BOLD MRI is Used

The **BOLD MRI Mapping** planning task is used in **iPlan**:

- To define the design matrix of the BOLD MRI experiment based on the BOLD MRI data loaded to the treatment plan
- To calculate 3D BOLD MRI objects



**Only use the application if you have advanced clinical experience and BOLD MRI background. If required, contact your radiology department for assistance.**



**Due to the inherent uncertainty, along with statistical analyses, and the low quality of the underlying MR EPI images, the result should be seen as parametrical information related to the brain activity. The image processing result for BOLD MRI data depends on patient contribution to the measurement, data accuracy, image processing and user settings. Be aware that the user settings have a high influence on the displayed parametrical results.**

---

## Valid Data Sets

3D BOLD MRI objects can only be created from anatomical data (MR, for example). Therefore, make sure to fuse the BOLD MRI data to an anatomical image set using the **Image Fusion** function.

To provide valid data sets, anatomical and BOLD MRI data must be from the same patient. It is very important to never create inconsistent datasets. If you import functional data to an already existing treatment plan, you are explicitly asked if you would like to create a new patient or if the newly imported data can be merged into the existing plan.

---

## Before You Begin

Steps	
1.	Acquire BOLD MRI data according to the Brainlab scanning instructions available from Brainlab support.
2.	Import the BOLD MRI and anatomical data set (see page 38).
3.	Perform image fusion (see page 147) between the BOLD MRI data and other available image sets in order to combine anatomical and functional information.

*NOTE: MR data with BOLD-similar characteristics (e.g., perfusion time series) can be mistakenly detected as a valid BOLD MRI study.*

## 14.1.1 BOLD MRI Image Processing

---

### BOLD MRI Quality

BOLD MRI data is based on fast EPI MRI sequences, which are susceptible to macroscopic magnetic field inhomogeneities.

These inhomogeneities result from the magnetic susceptibility differences at air-tissue interfaces, for example, near the auditory canals and the cavities at the cranial base.

The resulting images can be affected by signal loss and geometric distortions.

---

### Activation Map Quality

The results of BOLD MRI processing depends on:

- The BOLD MRI quality (see above)
- The reproducibility of the functional task paradigm
- The patient's contribution when performing the tasks
- The preprocessing settings used during the data import (smoothing, motion correction)
- Internal statistical calculation



**Depending on the scanner configuration and protocols, the BOLD MRI images may have distortions. The correctness of the BOLD MRI data must be compared to other anatomical data and confirmed during the image fusion.**



**Depending on the scanner configuration and sequence parameters, the images may have distortions in the frontal brain area. BOLD MRI images can be fused to higher resolution anatomical images sets using a specific region of interest in the Image Fusion planning task (see page 147).**



**The BOLD MRI data is an indirect measurement of neural activity, and is sensitive to influence by non-neural changes in the body. The BOLD MRI measurement shows the blood oxygenation, not only in brain areas, but also in cerebral veins. When comparing the BOLD MRI results with the anatomical data, these areas should be interpreted accordingly.**



**Depending on the brain area, the hemodynamic responses may differ, thus generating variable intensities. Plausible interpretation of the BOLD MRI results can only be achieved by meticulous choice of appropriate analysis and parameters. The BOLD MRI parameters used for processing should be adjusted for each measurement accordingly.**

---

### Motion Correction Parameters

Check motion correction parameters during import, as these parameters convey important information on data quality. If the correction values are too high, the data may be irreversibly damaged, resulting in distorted BOLD MRI analysis results.

---

### Mapping Brain Activity

In neurosurgery, the primary area of interest is the location of the motoric areas relative to the brain tumor. Reproducible brain activity can be achieved using motoric paradigms such as:

- Finger tapping
- Opening and closing the hand
- Foot movement
- Tongue movement



**BOLD MRI is sensitive to movement. Limit functional tasks to those without head movement.**



**Be aware that the image processing result for BOLD MRI data depends on patient contribution to the measurement, measurement accuracy, image processing and user settings. These factors significantly impact the accuracy of the functional areas of interest.**



## 14.1.2 BOLD MRI Mapping Functions

### Main Screen

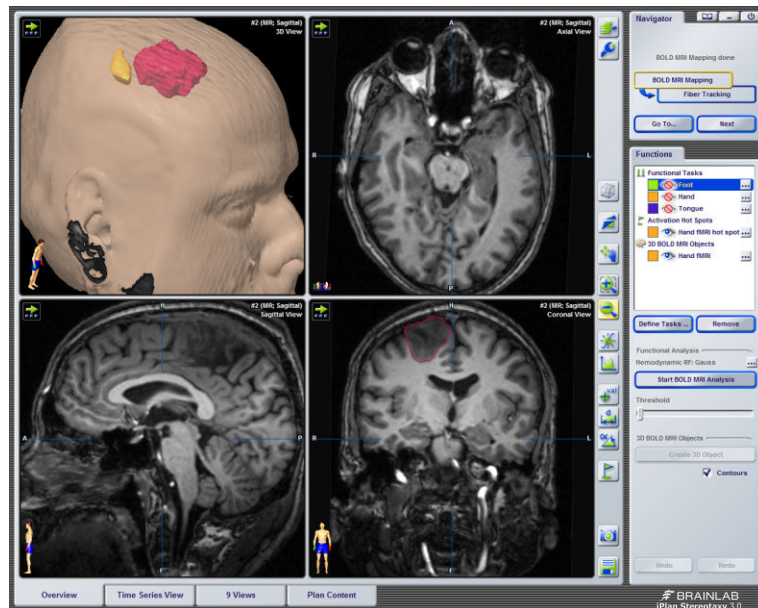



Figure 87

### Functions Overview

Function	Explanation	See
List box	Lists functional tasks, activation hot spots and 3D BOLD MRI objects that you have added. From here you can modify the visibility, color and properties of the items in the list.	Page 63
Define Tasks	Define a design matrix for a particular functional task, based on the parameters recorded during scanning	Page 203
Remove	Delete a functional task, a hot spot or a selected 3D object from the list	Page 214
Functional Analysis	 Click the properties button to define analysis options	Page 203
Start BOLD MRI Analysis	Analyze the BOLD MRI data for the defined tasks	Page 205
Threshold	Adjust threshold for the calculated BOLD MRI activations	Page 205
Create 3D Object	Create a 3D BOLD MRI object from the BOLD MRI data	Page 212
Contours	Show the 3D BOLD MRI object tinted in color or as a contour only	Page 214

## 14.2 BOLD MRI Mapping

### Selecting the BOLD MRI Study

#### How to Select the Study

If more than one BOLD MRI has been imported to your treatment plan, the **Studies** dialog opens when you enter **BOLD MRI Mapping**. Here you can select the BOLD MRI study in which to perform BOLD MRI mapping.

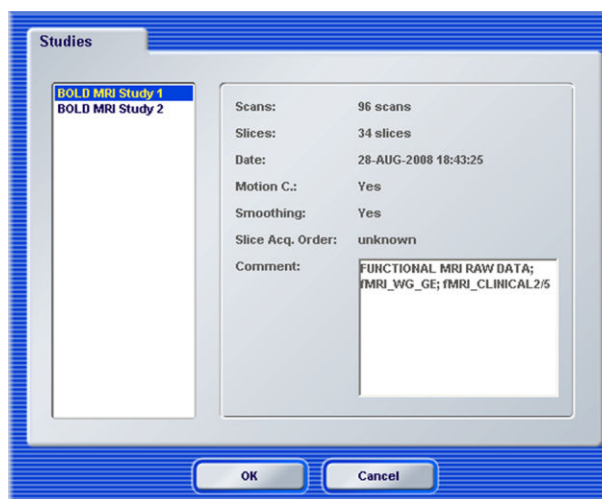

Figure 88

Steps	
1.	Select relevant BOLD MRI study.
2.	Review the information displayed on the right side of the dialog.
3.	To confirm your selection and close the dialog, click <b>OK</b> . You can now define the design matrix (see page 203).

#### Verifying BOLD MRI Data



Depending on the scanner configuration and protocols, BOLD MRI images may be distorted. To ensure that the data is correct, the BOLD MRI images must be compared to anatomical data and verified during image fusion.

#### System Messages

To ensure that valid data sets are used for treatment planning, any BOLD MRI data that you load must be from the same patient as the anatomical data. If you attempt to import new DICOM data from a patient that has a different name or ID, the software displays a warning message.

- If you click **Yes** in the message, the images will be loaded to the current treatment plan. Only use this option if you are sure the patient data is from the same patient you have already loaded.
- If you click **No**, the selected data will not load to the plan.



The BOLD MRI data set and anatomical data (e.g., MR and CT images) must be from the same patient, and be labeled with the same patient name and ID. Merging BOLD MRI data sets with anatomical data sets from different patients will result in invalid results.

## 14.2.1 Defining the Design Matrix

### General Information

The design matrix is based on parameters that are used during scanning. At the scanner, the scanner operator defines the BOLD MRI sequence and the paradigm.

During the scan, the patient must perform the defined functional tasks (e.g., finger tapping). It is possible to use data that contains more than one task in one study, for example a finger tapping task, followed by a foot movement. The software lists all defined functional tasks. One or more of these tasks can then be selected to be used for the analysis.

### Task Paradigm Dialog

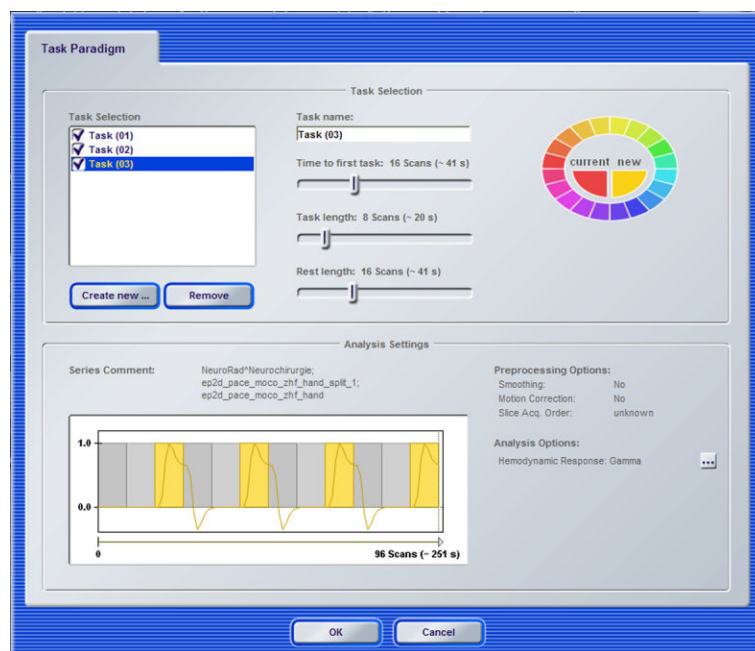

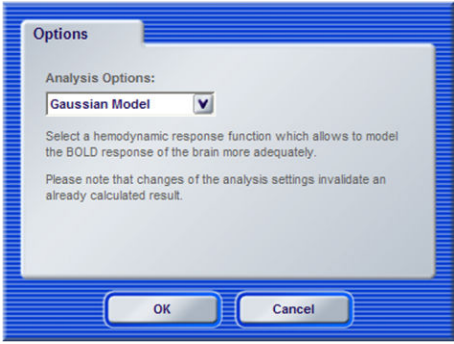

Figure 89

### How to Define a Task

Steps	
	Click <b>Define Tasks</b> in the functions area.
1.	The <b>Task Paradigm</b> dialog opens where you can define the settings for the design matrix.
2.	Click <b>Create new...</b> and enter a name in the <b>Task name</b> field (for example, Hand).
3.	In the <b>Time to first task</b> field, drag the slider to define the time or number of (dummy) scans which were acquired before the first task.
4.	In the <b>Task length</b> field, drag the slider to define the length of the task in seconds or in terms of the number of scans for which the specified task was performed.
5.	In the <b>Rest length</b> field, drag the slider to define the length of time or scans during which the patient was resting.
6.	Select a color for the functional task from the palette.
7.	 To define <b>Analysis Options</b> , click the properties button. The <b>Options</b> dialog opens.

Steps	
	 <p>8. Select from the available options: <b>Gamma Model</b>, <b>Gaussian Model</b>, or <b>None</b>, and click <b>OK</b> to confirm your selection.</p>
9.	<p>In the <b>Task Paradigm</b> dialog, click <b>OK</b> to confirm your settings.</p> <p>The new task is now added to the <b>Functional Tasks</b> list in the functions area and can be used for BOLD MRI analysis.</p>

*NOTE: The parameters required for the design matrix entered here must be provided by the radiology department.*

## Parameter Display

The entered parameters are displayed as a graph in the **Task Paradigm** dialog. On the right, information on the scan protocol used is provided together with preprocessing settings (smoothing, slice time correction and motion correction).

Slice time correction diminishes artefacts due to different slice acquisition times. To use this option, the slice acquisition order must be correctly specified. If the slice acquisition order is not known, slice time correction will not be applied.

If the selected task parameters do not match the loaded BOLD MRI image series, a warning is displayed.

In the example in Figure 89, the “tongue” task was completed with:

- 0 scans offset, without patient activation
- During the scan of 8 scans (20 seconds), the patient performed tongue movement, and
- During the scan of 16 scans (40 seconds) there was no patient activation

If a functional task is no longer required, clicking **Remove** deletes it from the **Task Selection** list.



**For a correct analysis, the entire functional paradigm must be defined as functional tasks. The user must make sure that the chosen settings correspond to the current experimental settings.**

A correlation coefficient between functional paradigm (specified tasks) and measured time series is calculated in accordance with the commonly accepted Pearson method.

*NOTE: BOLD MRI supports only block-oriented functional paradigms. Event-oriented paradigms are currently not supported.*

## 14.2.2 Analyzing BOLD MRI Data

### General Information

Once the functional tasks have been defined (see page 203), data analysis can begin.

### How to Activate Data Analysis

#### Step

To start functional analysis for all defined tasks, click **Start BOLD MRI Analysis**.

The progress bar in the functions area displays the status of the operation.

### Displayed Results

The calculated image processing result is displayed in the image views according to the color assigned for each task.

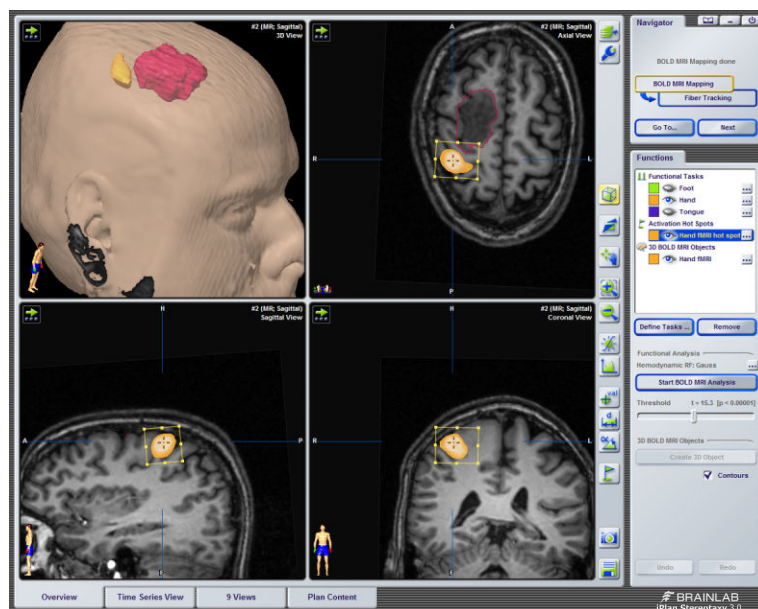

Figure 90

Once analysis is complete, the areas in the image data containing relevant signal information are colored in, according to the level of signal activity detected and the color assigned to the relevant task.

### Adjusting the BOLD MRI Threshold

You can use the **Threshold** slider in the functions area to adjust the range of the colored activation area.

The **Threshold** slider helps distinguish activated pixels (those with a probability of activation higher than the threshold value) from non-activated pixels. The current threshold level and the probability value (p-value) for false positive activations are shown above the slider.

#### Options

Drag the slider to the right to increase the minimum signal intensity required for display. The activation area shown is thus reduced accordingly.

*NOTE: The greater the signal intensity, the paler the color.*

Drag the slider to the left to include areas with a lower BOLD MRI signal intensity.



**The threshold applied in BOLD MRI Mapping following a successful analysis is a default threshold with a statistical significance of  $p=0.001$ . This is only a proposed threshold. Before interpreting and using the data, the user must consider the proposed value and adjust the threshold if necessary. The threshold value has a strong influence on the displayed result.**

# 14.3 Time Series View Tab

## Overview

### General Information

The **Time Series View** tab allows you to inspect the BOLD MRI activation signal data in order to:

- Facilitate the correct threshold adjustment
- Assess the displayed activations
- Cross-check the results with the specific paradigm

Additionally, you can select a specific voxel in the image set to display the corresponding signal over time and to superimpose these with graphs, showing the motion correction parameters (if applied during import), and thus possible coincidences with motion induced artefacts.

### Screen Layout

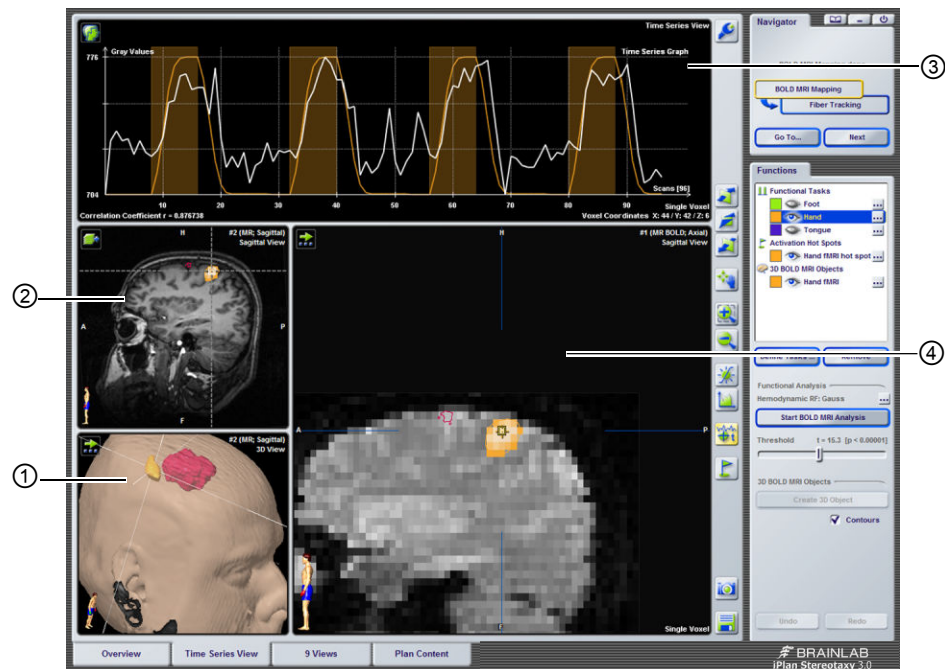

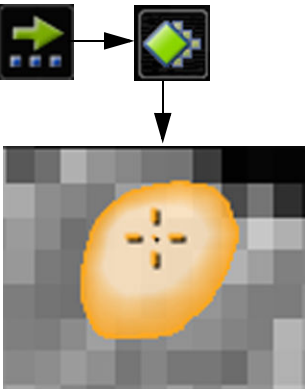

Figure 91

No.	View	Explanation
①	3D configuration view	Configure various view options (see page 82)
②	Set selection view	Select the displayed image set (see page 274)
③	Time series view	The functional task selected in the functions list is shown here, and can be overlaid with information such as signal strength over time, motion correction, etc.
④	Voxel selection view	Here you can select a voxel upon which the time series graph is based

## Interpolation Settings

Options	
	<p>Following initial functional analysis (see page 212), the area of activation in the voxel selection view is displayed in accordance with the actual voxel distribution, shown here.</p>
	<p>To aid visual interpretation of the displayed information, first click the arrow button in the voxel selection view, and then click the interpolation icon.</p>







### 14.3.1 Signal Display

#### General Information

In the **Time Series** view, the functional task selected in the functions list is shown overlaid on a timeline comprised of the number of scans taken. Initially, no other information is provided.

#### How to Activate the Signal Display

To display signal intensity at a particular location over time, you must select the required voxel or set of voxels in the voxel selection view.

Steps	
1.	 <p>First click the arrow button in the voxel selection view, and then click the <b>Time Series Options</b> icon.</p>
2.	 <p>Select the time series option: <b>Single Voxel</b>, <b>3 x 3 Voxel</b>, or <b>5 x 5 Voxel</b>.  <i>NOTE: If 3 x 3 Voxel or 5 x 5 Voxel are selected, an average value is taken for the corresponding signal. This offers more reliable assessment of functional activation.</i></p>
3.	 <p>Ensure that the <b>Select Timeseries</b> icon in the toolbar is activated (yellow).</p>
4.	 <p>In the voxel selection view, click on the colored activation area representing the currently selected functional task.                  A yellow frame indicates the area considered for signal display. You can adjust the frame using the mouse pointer (shown as a cross-hair).  <i>NOTE: Areas of strong signal intensity are pale in color.</i></p>

#### Graph with Signal Display

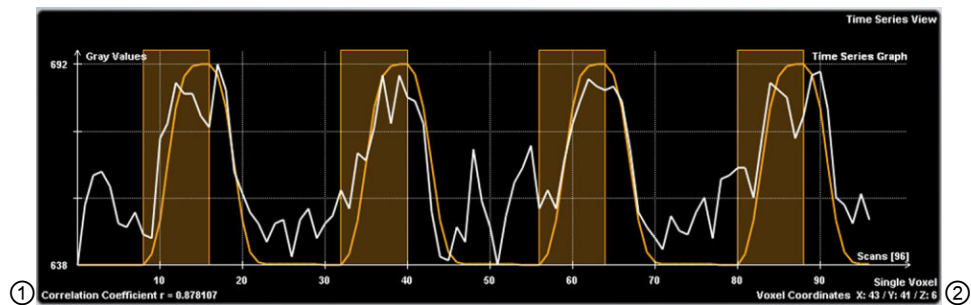

Figure 92

Once you have selected the voxels, the corresponding BOLD MRI signal intensity (y-axis) over time (x-axis) is shown in white on the graph.

The stronger the signal over each of colored bars (i.e., the higher the gray value level), the greater the likelihood is that the signal is not merely a result of random artefacts.

A correlation coefficient for the functional task and the time series for the selected voxel area is calculated ①.

The x, y and z coordinates of the selected voxel area are provided ②.

The mean value (bottom right of the graph) indicates the type of area you have selected (single voxel, 3 x 3 interpolated or 5 x 5 interpolated).





**Due to the inherent uncertainty in combination with the statistical analyses and the largely poor quality of the underlying MRI EPI images, the result should be seen as parametrical information related to the brain activity.**

### 14.3.2 Motion Correction

#### General Information

If motion correction has been applied during import (see page 42), the corresponding translation and rotation parameters can also be displayed in the time series view.

#### How to Activate Motion Correction Information

Steps	
1.	 <p>Click the <b>Motion Correction</b> icon (top left of the screen).</p>
2.	 <p>Select the motion correction option: <b>None, Translation, Rotation.</b></p>

#### How to Interpret the Graph

The graph in the time series view is updated in accordance with the x, y and z direction of the patient coordinate system.

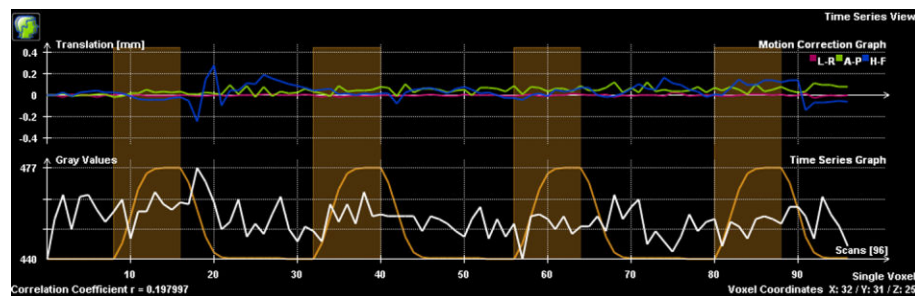

Figure 93

- R-L (right to left) motion is displayed as a red line
- A-P (anterior to posterior) information is displayed as a green line
- H-F (head to foot) information is displayed as a blue line

Translational information is indicated in millimeters. Rotational information is indicated in degrees.

## 14.4 3D BOLD MRI Objects

### Defining the Region of Interest

#### General Information

When BOLD MRI analysis is complete, you can create a three-dimensional model of the BOLD MRI structure to export for use with the Brainlab navigation software.

#### Using the Region of Interest Function

Before generating the 3D object, you can use the **Region of Interest** function in the toolbar to e.g., eliminate false activations from blood vessels. This function can also be used to separate motoric activation areas.

*NOTE: The **Region of Interest** function is automatically activated following a successful BOLD MRI analysis.*

#### How to Define the Region of Interest

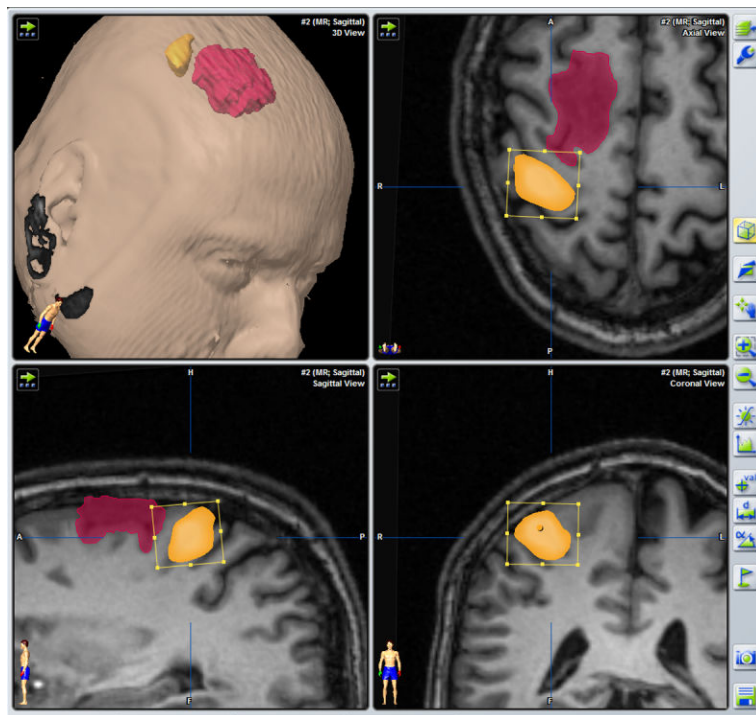



Figure 94

Steps	
1.	 Click the region of interest icon in the toolbar if it is not already activated (yellow).
2.	Use the mouse pointer to adjust the size and position of the yellow dotted frame in the image views so it is placed over the desired region of interest.



**When generating 3D objects from functional areas, make sure that important activations are inside the region of interest. If the region of interest is disabled, all BOLD MRI areas from the current task will be used to generate the 3D object.**

## 14.4.1 Creating 3D BOLD MRI Objects

### Before You Begin

Because anatomical image sets (MR for example) provide higher resolution data, a 3D BOLD MRI object can only be created from anatomical data. Therefore, make sure to fuse the BOLD MRI data to an anatomical image set (see page 147), and to verify the fusion result to ensure the accuracy of the 3D structure.

To create a BOLD MRI 3D object you must first:

- Complete BOLD MRI analysis for the relevant functional task (see page 205)
- Define a region of interest for the 3D object within the functional task activation area (see page 212)

### How to Create 3D BOLD MRI Objects

Steps	
1.	Select the functional task from the list in the functions area.
2.	Click <b>Create 3D Object</b> to open the <b>Properties</b> dialog.
3.	In the <b>Name</b> field, edit the object name if required.
4.	From the <b>Image Set</b> list, select the fused image set to which the 3D BOLD MRI object should be linked.
	To create an activation hot spot (indicating the area of maximum signal intensity) for the 3D object, select <b>Create Activation Hot Spot</b> .
5.	<i>NOTE: A functional hot spot marks the voxel with the highest activation within a certain region of interest for a specific functional task. This supports the user in evaluating the resulting activations, as well as in focusing on the activation hot spots. Hot spots can be created along with the creation of a voxel object, but only when a region of interest is defined.</i>
6.	Click on the <b>Select Color</b> tab and select a color for the 3D BOLD MRI object.
	Click <b>OK</b> to confirm your settings.
7.	The 3D BOLD MRI object is added to the list in the functions area, and displayed in the image views in the planning area.

### Displayed 3D BOLD MRI Objects

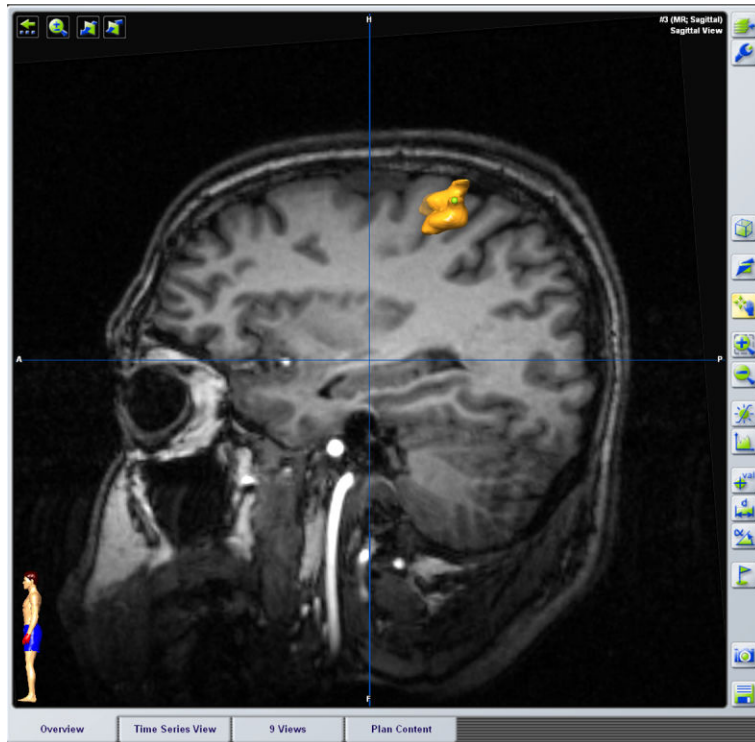

Figure 95



The color of BOLD MRI hot spots and 3D objects may change during the export to navigation.

### Adjusting the 3D Display

Options
To show the 3D object as an outline only, click the <b>Contours</b> check box in the functions area to enable it.
To show the 3D object tinted in the selected color, click the <b>Contours</b> check box.

### Functional Structures and Anatomical Data



The anatomical high resolution MRI scan may have another field of view compared to the BOLD MRI data. Depending on the dimensions of the anatomical data and the location of the found activation areas, generated objects may be only partially created or created not at all within the anatomical volume.



The result of BOLD MRI processing should be verified carefully and only confirmed if you are sure it corresponds to known anatomical regions.

### How to Remove 3D BOLD MRI Objects

Steps
1. Select the 3D BOLD MRI object from the list.

<b>Steps</b>
2. Click <b>Remove</b> .





# 15 FIBER TRACKING

## 15.1 Introduction

### Overview

---

#### General Information

**Fiber Tracking** allows you to track fiber structures in a defined region of interest, based on diffusion-weighted MR images.

**Fiber Tracking** is available once you have loaded a DTI data set to the current treatment plan.

---

#### Basis for Fiber Tracking

**Fiber Tracking** is based on the measurement of diffusion anisotropy in the brain using diffusion-weighted images (DTI data) taken in several directions.

The direction of water diffusion along potential white matter fibers is calculated for the entire data volume. This allows **iPlan** to trace the direction of fibers in a selected region of interest and display the direction according to a color code, where certain colors represent a particular direction.

Using **iPlan**, you can select fiber bundles starting with the region of interest, and then convert the fiber bundle to a 3D object to be used for further planning.

---

#### Before You Begin

3D fiber objects can only be created from anatomical data (MR for example). Therefore, make sure to fuse the DTI data to an anatomical image set using the **Image Fusion** function.

Steps	
1.	Acquire DTI data according to the Brainlab scanning instructions available from Brainlab support.
2.	Import the DTI and anatomical data set (see page 23).
3.	Perform image fusion (see page 147) between the DTI data and other available image sets in order to combine anatomical and functional information.



Depending on the scanner configuration and protocols, the DTI images may be distorted, resulting in incorrect 3D object generation and placement. The correctness of the DTI data must be compared to other anatomical data and confirmed during image fusion.



To facilitate correct 3D object generation at the correct location, fuse the low-resolution B0 slice set with an anatomical slice set and confirm this fusion manually.

## 15.1.1 Fiber Tracking Functions

### Main Screen

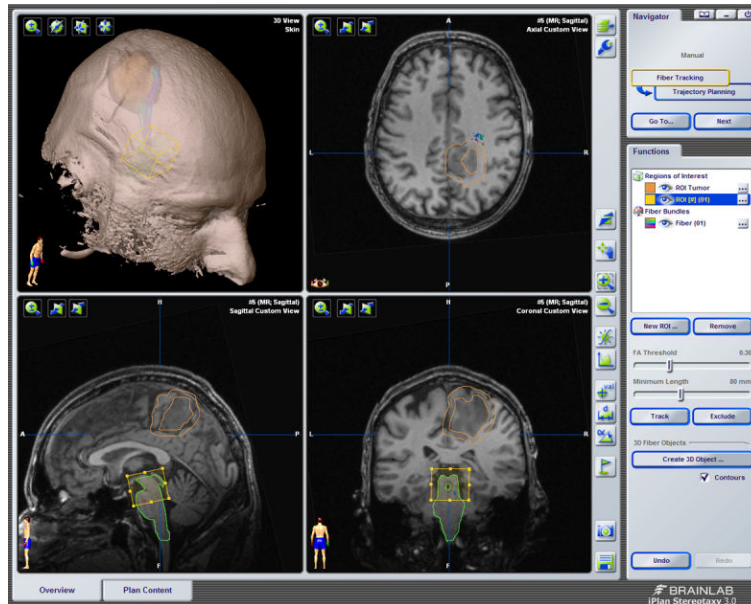

Figure 96

### Functions Overview

Function	Explanation	See
List box	Lists regions of interest, fiber bundles and 3D fiber objects that you have added. From here you can modify the visibility, color and properties of the items in the list.	Page 63
New ROI...	Create a region of interest.	Page 220
Remove	Delete a selected region of interest, a fiber bundle or a 3D fiber object from the list.	Page 227
FA Threshold	Adjust the minimum diffusion value taken into account when tracking fibers.	Page 223
Minimum Length	Adjust the minimum length of fibers to be tracked.	Page 223
Track	Starts tracking fibers according to defined parameters and current region of interest.	Page 224
Exclude	Excludes particular fibers from all visible fibers passing through one or more visible regions of interest (ROI).	Page 163
Create 3D Object...	Create a 3D model of the tracked fibers.	Page 226
Contours	Show the 3D fiber object tinted in color or as a contour only.	Page 227

## 15.2 Using Fiber Tracking

### Selecting the DTI Study

#### How to Select the Study

If more than one DTI study has been imported to your treatment plan (e.g., if you have imported a study with six diffusion directions and another study with twelve directions), the **DTI Study** dialog opens when you enter the **Fiber Tracking** planning task. Here you can select the DTI study in which to track fibers.

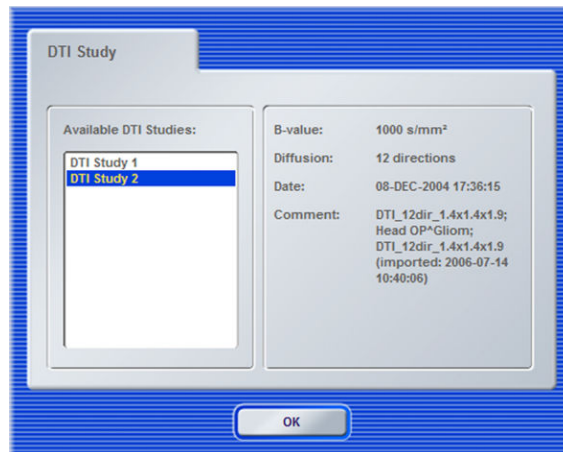

Figure 97

Steps
1. From the <b>Available DTI Studies</b> list, select the DTI study.
2. Review the information displayed on the right side of the dialog.
3. To confirm your selection and close the dialog, click <b>OK</b> .

#### Verifying DTI Data



If you click the **Abort** button beneath the progress bar during DTI import, the software may still calculate a diffusion tensor. This resulting diffusion tensor, however, may be incorrect. In this case you should verify the diffusion data (e.g., number of images) to confirm that all necessary data has been imported.



Depending on the scanner configuration and protocols, DTI images may be distorted. To ensure that the data is correct, the DTI images must be compared to anatomical data and verified during image fusion.

#### System Messages

To ensure that valid data sets are used for treatment planning, any DTI data that you load must be from the same patient as the anatomical data. If you attempt to import new DICOM data from a patient that has a different name or ID, the software displays a warning message.

- If you click **Yes**, the images will be loaded to the current treatment plan. Only use this option if you are sure the DTI patient data is from the same patient you have already loaded.
- If you click **No**, the selected data will not load to the plan.



The DTI data set and anatomical data (e.g., MR and CT images) must be from the same patient, and be labeled with the same patient name and ID. Merging DTI data sets with anatomical data sets from different patients will result in invalid results.

## 15.2.1 Defining the Region of Interest for Tracking

### How are Fibers Tracked?

The software reconstructs fiber bundles by tracking the direction of the local diffusion. By connecting a number of points, the fiber is reconstructed as a line. The software starts from a region of interest (ROI) that you define, and connects diffusion areas with similar FA values.

### Background

In order to create fiber structures in your treatment plan, you must first define the initial region of interest in the selected image set. When you define a region of interest, all fibers which pass through the region are included in the fiber bundle.

You can create and use multiple regions of interest simultaneously. Selecting an ROI in the motoric area and another one in the brainstem, for example, allows the white matter tracts (e.g. pyramidal tract) connecting these areas to be displayed.

*NOTE: Once you define a region of interest, it is only used for fiber tracking if it is set to visible in the list view (see page 62).*

### How to Activate Region of Interest Definition

Steps	
1.	Click <b>New ROI ...</b> in the functions area to open the <b>ROI Properties</b> dialog.
2.	You now have the option of creating three different object types. In the <b>ROI Properties</b> dialog, select one of the following: <ul style="list-style-type: none"> <li>• <b>Manual 3D Object</b> (default setting, see page 220)</li> <li>• <b>Existing 3D Object</b> (see page 221)</li> <li>• <b>Cubic Box</b> (see page 222)</li> </ul>

### How to Define a Manual 3D Object

This option allows you to define the region of interest by manually creating an object in the image set.

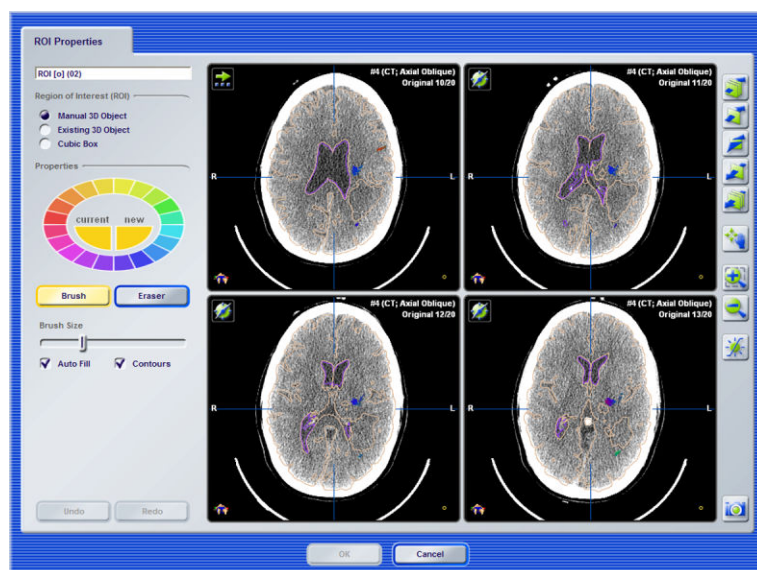

Figure 98

Steps	
1.	Enter a name for the region of interest in the <b>Name</b> field.
2.	Under <b>Region of Interest</b> , select <b>Manual 3D Object</b> .
3.	In the <b>Properties</b> area: <ul style="list-style-type: none"> <li>• Select a color for the object from the palette.</li> <li>• Use the <b>Brush</b> (see page 168) and <b>Eraser</b> (see page 195) functions to draw an object manually onto the image data provided in the image view.</li> <li>• As needed, activate/deactivate the <b>Auto-Fill</b> (see page 194) and <b>Contours</b> (see page 194) check-boxes.</li> </ul>
4.	Click <b>OK</b> to add the region of interest to the list in the functions area.

**How to Select an Existing 3D Object**

This option allows you to define a region of interest based on objects created using the **Object Creation** planning task (see page 163).

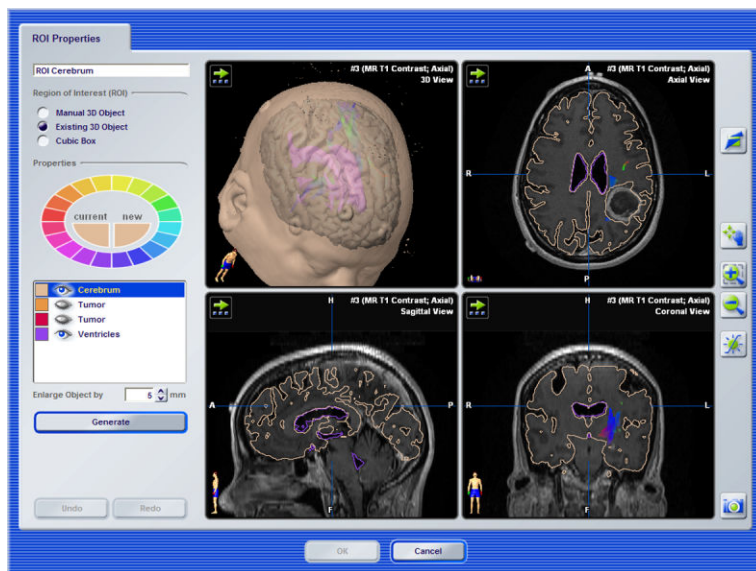

Figure 99

Steps	
1.	Enter a name for the region of interest in the <b>Name</b> field.
2.	Under <b>Region of Interest</b> , select <b>Existing 3D Object</b> .
3.	In the <b>Properties</b> area: <ul style="list-style-type: none"> <li>• Select a color for the object from the palette.</li> <li>• Select the anatomical structure from the list to be used as a basis for the region of interest, e.g., the tumor or <b>BOLD MRI</b> activations.</li> <li>• In the <b>Enlarge Object by</b> field, click the arrow buttons, or enter a value in the field to define a border around the anatomical structure to be used for sizing the object.</li> </ul>
4.	Click <b>Generate</b> to create a preview of the object.
5.	Click <b>OK</b> to add the region of interest to the list in the functions area.

## How to Define a Cubic Region of Interest

This option allows you to define a region of interest by surrounding the required area with a cubic frame.

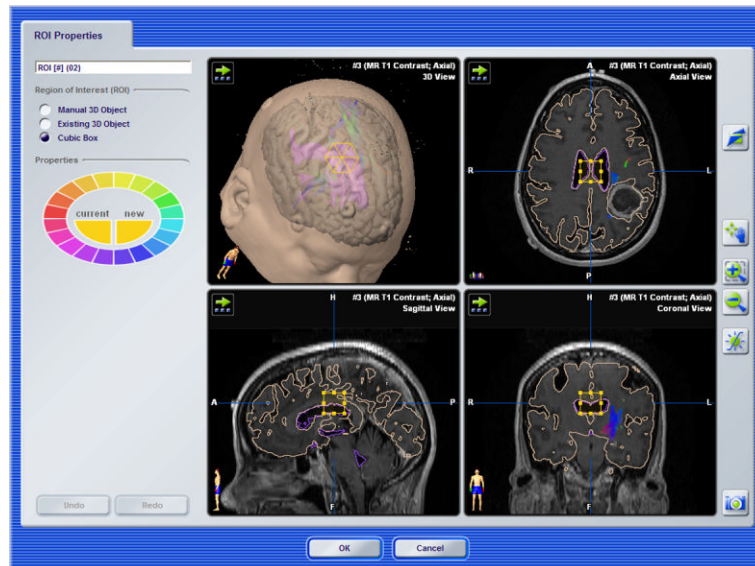

Figure 100

Steps	
1.	Enter a name for the region of interest in the <b>Name</b> field.
2.	Under <b>Region of Interest</b> , select <b>Cubic Box</b> .
3.	In the <b>Properties</b> area, select a color for the object from the palette.
4.	In the image views, use the mouse pointer to position and resize the region of interest (indicated by the frame) until the area to be used for fiber tracking has been enclosed.
5.	Click <b>OK</b> to add the region of interest to the list in the functions area.

## Next Steps

Once you have defined the region of interest, you can:

- Adjust the tracking parameters (if required, see page 223).
- Begin tracking fibers (see page 224).

## 15.2.2 Adjusting the Tracking Parameters

---

### General Information

Before tracking fibers in the defined region of interest, you can review and adjust the fiber tracking parameters (if required) in order to optimally track fibers in the image set.

---

### How to Adjust the FA Threshold

The FA threshold is the minimum value of diffusion that will be considered for tracking fibers. Depending on the DTI data that has been imported to the treatment plan, this setting may need to be adjusted.

- A lower threshold setting enables smaller and less important fibers to be tracked.
- A higher threshold setting reduces noise and displays more prominent fibers.

Step
Drag the <b>FA Threshold</b> slider bar in the functions area to adjust the threshold to the required level. <i>NOTE: The threshold level is displayed above the slider bar. The default setting is 0.3.</i>

---

### How to Adjust the Minimum Length

Step
Drag the <b>Minimum Length</b> slider bar in the functions area to define the minimum length in millimeters of the fibers to be tracked. <i>NOTE: The length is displayed above the slider bar. The default setting is 80 mm.</i>

### 15.2.3 Tracking Fibers

#### General Information

The **Start Tracking** function allows the software to track all fibers that intersect with the active regions of interest and meet the defined criteria (**FA Threshold** and **Minimum Length**). This function is enabled when one or more regions of interest are visible.

#### How to Activate Fiber Tracking

Steps	
1.	Select the region of interest from the list in the functions area.
	To track fibers, click <b>Start Tracking</b> .
2.	Once the process is completed, the software displays the fibers in different colors according to the diffusion direction and the fiber bundle is added to the list in the functions area.

#### Displayed Fibers

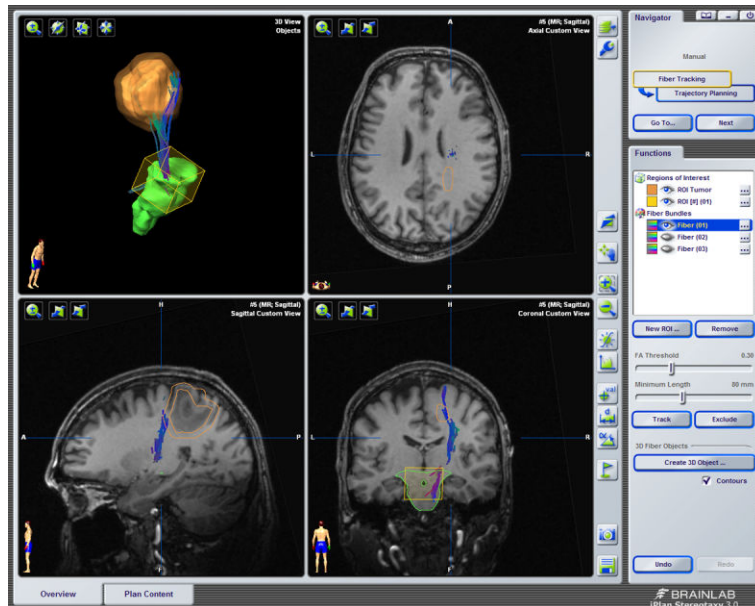



Figure 101

Fiber Color	Diffusion Direction
Red	Left-right
Green	Anterior-posterior
Blue	Head-foot

*NOTE: Depending on the image angulation, the fiber color-coding may differ from above.*

#### Visibility of Fiber Bundles

Options	
	An open eye icon next to the fiber bundle in the list in the functions area means the fiber bundle is visible. Click the eye symbol to hide the fiber bundle.



**Options**

A closed eye icon means the fiber bundle is hidden.  
Click the eye symbol to show the fiber bundle again.

---

**Windowing Settings**

You can adjust windowing settings for the displayed images at any time using the **Windowing** (see page 286) or the **Advanced Windowing** (see page 287) buttons in the toolbar. As windowing is just a visual threshold, changing these settings will not affect the fiber tracking calculations.

---

**Fiber Tracking Results**

The fiber tracking result is based on calculations from diffusion tensor images. iPlan only displays the relative representation of local anisotropy that is related to fiber structures in brain white matter.



The original diffusion information from the scanner may be affected by the tumor type, size and location. If edema is present, anisotropic information may be lost or distorted.



The tracking algorithm tracks fibers that fulfill the current threshold and minimum length settings (see page 223). If these settings are too high or too low, the tracked fibers may differ from the actual anatomical structure. The resulting fibers should never be seen as an absolute representation of anatomical structures, and rather as a representation of the local diffusion passing through the chosen region of interest. Further information is provided in the scanning instructions available from Brainlab support.

## 15.3 3D Fiber Objects

### Creating 3D Fiber Objects

#### General Information

When fiber tracking is complete, you can create a three-dimensional model of the fiber bundle to export for use with the Brainlab navigation software.

#### Before You Begin

Because anatomical image sets (e.g., MR) provide higher resolution data, the 3D fiber object can only be created from anatomical data. Therefore, make sure to fuse the DTI data to an anatomical image set (see page 147) and to verify the fusion result to ensure the accuracy of the 3D object.

#### How to Create a 3D Object

Steps	
1.	Select the fiber bundle from the list in the functions area.
2.	Click <b>Create 3D Object...</b> to open the <b>Properties</b> dialog (see page 63).
3.	In the <b>Name</b> field, enter a name for the 3D fiber object.
4.	From the <b>Image Set</b> list, select the fused image set to which the 3D fiber object should be linked.
5.	Click on the <b>Select color</b> tab and select a color for the 3D fiber object.
6.	Use the <b>Opacity</b> slider bar to define how opaque the 3D fiber object should be displayed in 3D image views.
	Click <b>OK</b> to confirm your settings.
7.	The 3D fiber object is added to the list in the functions area, and displayed in the image views in the planning area.

*NOTE: You can track different fiber bundles and create as many 3D fiber objects as are required for your treatment plan.*

#### Fiber Objects and Anatomical Data



Depending on the dimensions of the anatomical data and the location of the tracked fibers, generated 3D fiber objects may be only partially created, or not created at all within these slice sets. If the tracked fibers are located in areas that are not completely covered by the anatomical slice set, a corresponding warning message is displayed. If no fibers within the anatomical data set can be converted to a 3D object, the software displays a warning and the generation of the 3D object is aborted.

### Example 3D Fiber Object

An example of the pyramidal tract as a 3D fiber object is shown in the image below.

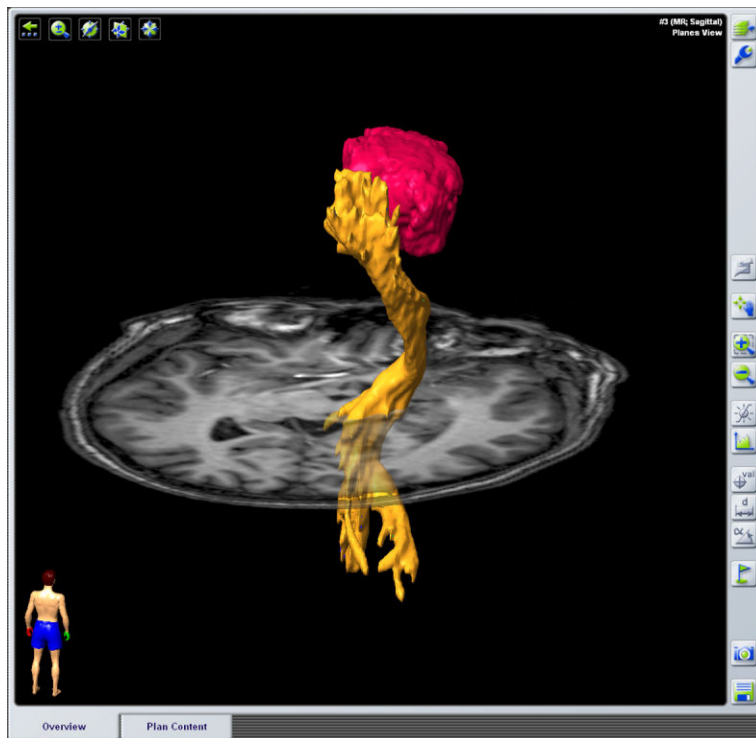

Figure 102

### Adjusting the 3D Display

Options
To show the 3D object as an outline only, click the <b>Contours</b> check box in the functions area to activate it.
To show the 3D object tinted in the selected color, click the <b>Contours</b> check box to deactivate it.

### How to Remove 3D Fiber Objects

Steps
1. Select the 3D fiber object from the list.
2. Click <b>Remove</b> .



# 16 STEREOTACTIC PLANNING

## 16.1 Introduction

### Overview

---

#### General Information

In **Stereotactic Planning**, you can:

- Plan possible pathways for the surgical instruments on the scanned images
- Calculate the stereotactic arc settings for the planned trajectory

## 16.1.1 Stereotactic Planning Functions

### Main Screen

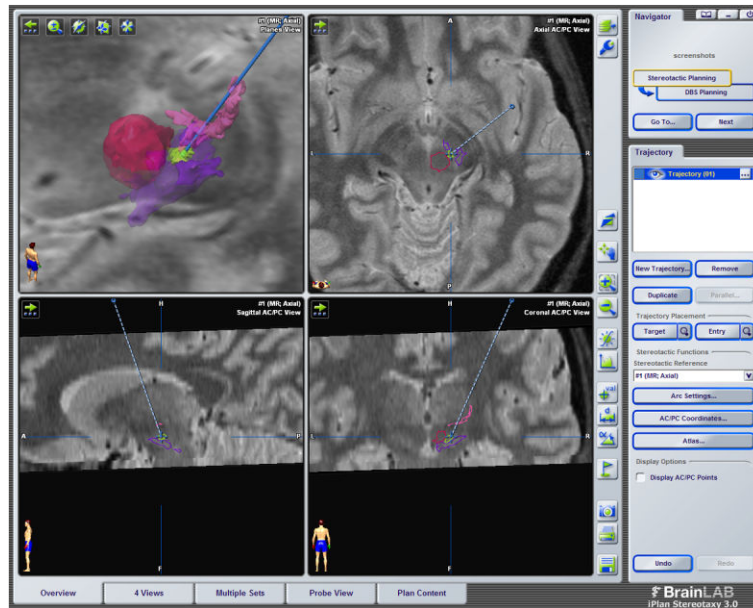

Figure 103

### Functions Overview

Function	Explanation	See
List box	Lists trajectories that you have added to the image set. From here you can modify the visibility, color and properties of the trajectories.	Page 63
New Trajectory...	Add a trajectory to the image set	Page 231
Remove	Remove a trajectory from the image set	Page 244
Duplicate	Duplicate an existing trajectory	Page 232
Parallel...	Create a trajectory that is parallel to an existing trajectory	Page 233
Target	Position or locate the trajectory target point	Page 231
Entry	Position or locate the trajectory entry point	Page 231
Stereotactic Reference	If multiple stereotactic localizations are available in the plan, select the localized image set to be used.	Page 234
Arc Settings...	Check and modify various arc settings	Page 234
AC/PC Coordinates...	Position the target and entry points based on the coordinates of the selected point	Page 236
Atlas...	Verify the planned trajectory in an atlas image and the corresponding patient images	Page 238
Display AC/PC Points	Display the AC and PC points if the selected image set is AC/PC localized, or fused to an AC/PC localized set	Page 244

## 16.2 Creating Trajectories

### Adding and Positioning New Trajectories

#### How to Add Trajectories

Steps	
1.	Click <b>New Trajectory...</b> to open the <b>Properties</b> dialog (see page 63).
2.	In the <b>Name</b> field, enter a name for the trajectory. <i>NOTE: If you do not name a trajectory, it is added to the list as <b>Trajectory</b> and numbered sequentially.</i>
3.	In the <b>Diameter</b> field, define a diameter for the trajectory (in millimeters).
4.	Select a color for the trajectory.
5.	Click <b>OK</b> to confirm your settings and to add the trajectory to the list in the functions area.

#### Naming Trajectories



Assign each trajectory a unique name so that it can be clearly identified.

#### How to Position Trajectories

Steps	
1.	Select the trajectory from the list in the functions area.
2.	Click the <b>Target</b> button, and then click on the image to place the target point. The target point is displayed as a cross-hair in the image.
3.	Click the <b>Entry</b> button, and then click on the image to place the entry point. The entry point is displayed as a circle and the trajectory from the entry point to the target point is displayed in the image. Examples of displayed trajectories are shown on page 245. <i>NOTE: You can also position the points on the surface of 3D structures in 3D views. If you position target and entries points in the 3D view, you should then verify the trajectory in the 2D views.</i>

*NOTE: To reposition points, you can also use the mouse pointer to drag the point to the required position.*

#### Viewing Trajectories

Once you have added a trajectory, you can view the trajectory in the image views and verify it as described on page 245.

## 16.2.1 Duplicating Trajectories

---

### Before You Begin

You must have at least one planned trajectory in the treatment plan.

---

### How to Create Duplicate Trajectories

Steps	
1.	Select a previously defined trajectory from the list in the functions area. Click <b>Duplicate</b> to add the trajectory to the list in the functions area.
2.	<i>NOTE: By default, the trajectory is named according to the existing trajectory, followed by <b>Clone</b>, and numbered sequentially.</i>

---

### Duplicated Trajectory

Duplicate trajectories are overlaid onto the original trajectory. You can reposition the new trajectory using the **Target** and **Entry** buttons (see page 231).



## 16.2.2 Creating Parallel Trajectories

### Before You Begin

You must have at least one planned trajectory in the treatment plan.

### How to Create a Parallel Trajectory

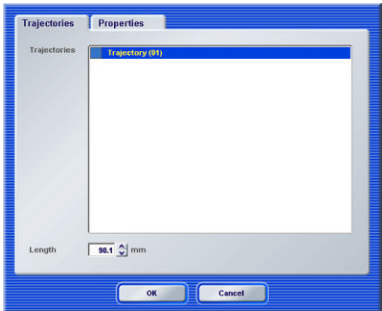
Steps	
1.	Click <b>New Trajectory...</b> to open the <b>Properties</b> dialog (see page 63).
2.	Define the name, diameter and color for the trajectory as described on page 231.
3.	Click <b>OK</b> to confirm your settings and to add the trajectory to the list in the functions area.
4.	Define either a target point or an entry point for the trajectory (see page 231).
5.	Once the target or entry point is positioned, click <b>Parallel...</b> in the functions area.
6.	 <p>In the <b>Trajectories</b> tab, select the existing trajectory to be used as the basis for the parallel trajectory. Define the length for the trajectory.</p> <p>Open the <b>Properties</b> dialog to define the name, diameter and color for the trajectory, and select the image set.</p>
7.	Click <b>OK</b> to confirm your settings and to add the trajectory to the list in the functions area. The new trajectory is displayed in the image, parallel to the original trajectory.

## 16.3 Arc Settings

### Overview

---

#### General Information

The **Arc Settings...** function allows you to:

- Check/modify the arc settings for the trajectory selected in the trajectory list
- Check/modify the mounting orientation of the arc system
- Modify the trajectory via the arc settings parameters in order to e.g., round values

*NOTE: Supported arc systems are described on page 121.*

---

#### Arc Setting Availability

**Arc Settings...** is enabled once:

- Stereotactic localization has been performed (i.e., the stereotactic reference is available), and
- The selected image set is the stereotactic reference or fused to the stereotactic reference, and
- A trajectory is planned in the selected image set or in fused sets

*NOTE: In order to calculate the arc settings for the planned trajectories, a stereotactically localized image set must be available.*



**If there is more than one stereotactically localized (or localizable) image set in the plan, all calculations are based only on one image set which must provide a valid localized coordinate system. You can select an image set from the Stereotactic Reference drop-down list in the functions area.**

---

#### How to Select the Stereotactic Reference

You can select the stereotactic reference if multiple stereotactic localizations are available in the plan.

Step
Select from the drop-down list the localized image set to be used for the calculation and display of the arc settings and heading coordinates, and for parallel track planning.

### 16.3.1 Using Arc Settings

#### How to Access Arc Settings

Step
Click <b>Arc Settings...</b> to open the <b>Arc Settings...</b> dialog.

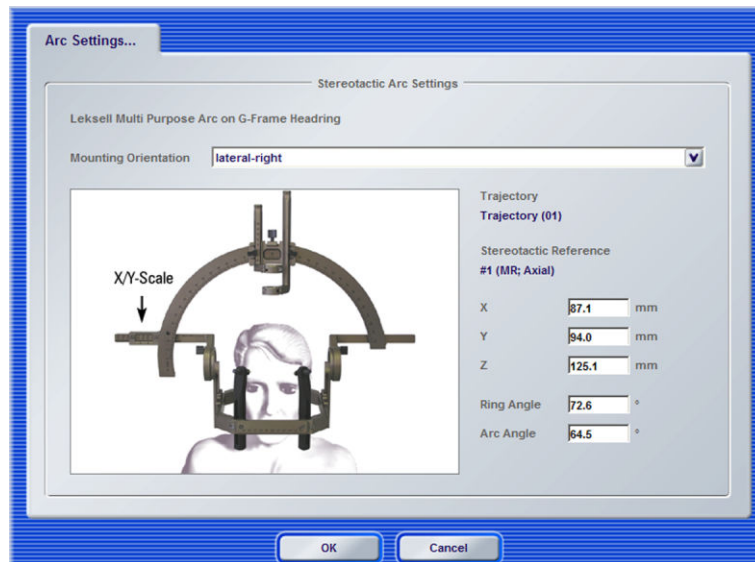

Figure 104

#### How to Adjust Arc Settings

Steps
1. To modify the mounting orientation of the arc system, select an option from the drop-down list ( <b>lateral-left</b> , <b>lateral-right</b> , <b>sagittal-anterior</b> or <b>sagittal posterior</b> ).
2. To adjust values for the target coordinates (in millimeters), enter the values in the fields provided (e.g., <b>X</b> , <b>Y</b> , <b>Z</b> ).
3. To adjust the values (in degrees) for the angle parameter, enter the value in the fields provided (e.g., <b>Ring Angle</b> , <b>Arc Angle</b> ).

*NOTE: Always specify the values in the given format (see also page 121). Otherwise the software may not accept your arc settings.*



The software cannot identify all potential collisions of stereotactic arc/hearing components. Thus, there is the potential that a trajectory cannot be adjusted on the arc system as planned. In such cases, you must plan alternative trajectories.

## 16.4 AC/PC Coordinates

### Overview

---

#### General Information

The **AC/PC Coordinates** function allows you to position the target and entry points for the trajectory based on the coordinates of the selected point.

*NOTE: Target and entry point planning via AC/PC Coordinates is just an auxiliary planning functionality which allows you to position trajectories in an image set.*



**The information provided by the AC/PC Coordinates function may be incorrect, inconsistent or inaccurate due to improper localization of the AC/PC system, or due to inherent insufficiencies of the planning methods based on the AC/PC system. To prevent patient injury, make sure to verify all trajectory positions in the patient image views (e.g., the Probe View and Overview tabs).**

---

#### AC/PC Coordinates Availability

The **AC/PC Coordinates** function is only enabled if:

- AC/PC localization has been performed in the selected image set, or
- The selected image set has been fused to an image set that is AC/PC localized

*NOTE: Modifying the AC/PC localization will not change the trajectories defined with the AC/PC Coordinates function. Trajectories will always retain their position relative to the image data in which they have been created.*

## 16.4.1 Positioning Target and Entry Points

### Before you Begin

Add a trajectory to the list in the functions area as described on page 231.

### How to Position Target and Entry Points

In this step, you position the target and entry points via AC/PC system relative coordinates.

Figure 105

Steps	
1.	Select the named trajectory from the list in the functions area.
2.	Click <b>AC/PC Coordinates...</b> to open the <b>Trajectory</b> dialog.
3.	Set the target coordinates (in millimeters or as a percentage of the AC/PC distance).
4.	For the entry point: <ul style="list-style-type: none"> <li>• Set the lateral angle</li> <li>• Select the angle direction (left or right) from the drop-down list</li> <li>• Set the distance to the target point to a reasonable length (approx. 50-70 mm) and modify the entry point in the Probe View mode afterwards. (This makes it easier to judge the trajectory's course and angle.)</li> </ul>
5.	Select the reference point ( <b>AC Point</b> , <b>MC Point</b> , or <b>PC Point</b> ) for the coordinate system. <i>NOTE: Depending on your settings, a default reference point is set.</i>
6.	Click <b>OK</b> to confirm your settings. The trajectory is now displayed in the image views.

## 16.5 Atlas Planning

### Overview

---

#### General Information

The Atlas... function provides three-dimensional information on the anatomical structure of the human brain as defined and described by the Schaltenbrand-Wahren brain atlas.

You can use this function to:

- Verify the planned trajectory by matching the patient images to the atlas images
  - Position the target and entry points for the set trajectory directly in the atlas images, as well as in a view containing patient images that have been reconstructed in the same plane as that of the atlas image
- 

#### Use of Atlas Planning



**The information provided by the Atlas... function may be incorrect, inconsistent or inaccurate due to improper co-registration of the atlas data to the patient (based on AC/PC localization) or due to inherent insufficiencies of the atlas data itself. To prevent patient injury, make sure to verify all trajectory positions in the patient image views (e.g., the Probe View and Overview tabs).**

---

#### Atlas Planning Availability

The **Atlas** function is available if:

- AC/PC localization has been performed in the selected image set, or
- The selected image set has been fused to an image set that is AC/PC localized, and
- If a trajectory was in planned in the selected image set, or in an image set fused to the selected set

## 16.5.1 Using the Atlas

### Before You Begin

Add a trajectory to the list in the functions area as described on page 231.

### How to Access the Atlas Dialog

Steps	
1.	Select the named trajectory from the list in the functions area.
2.	Click <b>Atlas...</b> to open the <b>Atlas</b> dialog.

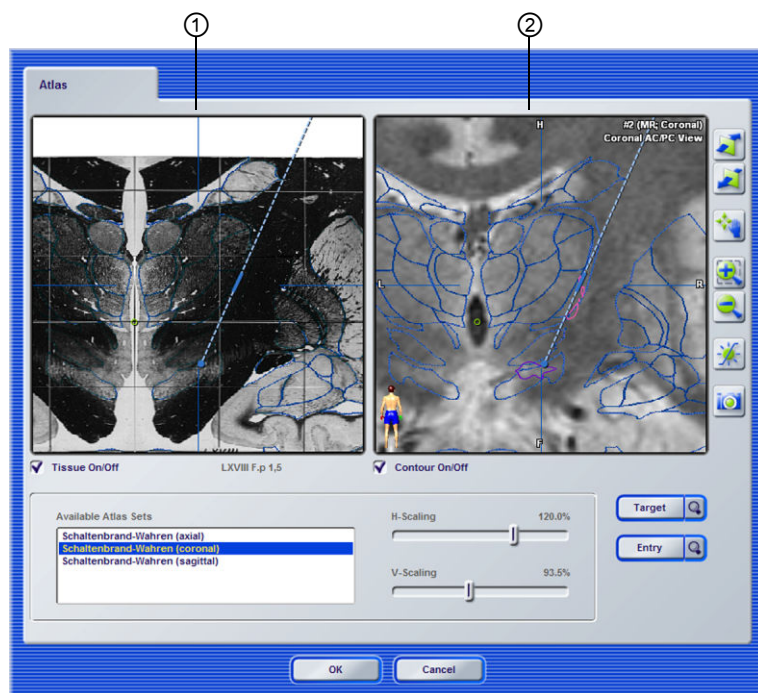

Figure 106

No.	Explanation
①	Atlas image
②	Patient image

*NOTE: Since the Schaltenbrand-Wahren Atlas is based on a combination of different brains, inconsistencies between the axial, coronal and sagittal slices may occur.*

*NOTE: The atlas images shown in the Atlas dialog are not reconstructed and only represent certain planes and positions in the brain.*

### How to Show/Hide Atlas Information

Options
To show/hide atlas tissue in the atlas image (left side of the dialog), enable/disable the <b>Tissue On/Off</b> check box.
To show/hide atlas contours superimposed on reconstructed patient images (right side of the dialog), enable/disable the <b>Contour On/Off</b> check box.

---

## How to Select Atlas Sets

Step
<p>From the <b>Available Atlas Sets</b> list, select the atlas set to be shown in the image on the left side:</p> <ul style="list-style-type: none"> <li>• <b>Schaltenbrand-Wahren (axial)</b></li> <li>• <b>Schaltenbrand-Wahren (coronal)</b></li> <li>• <b>Schaltenbrand-Wahren (sagittal)</b></li> </ul> <p>The corresponding patient image is shown on the right side.</p>

---

## How to Define the V-Scaling/H-Scaling

**V-Scaling** regulates the vertical scope of both the atlas image and the superimposed atlas contours on the patient image.

**H-Scaling** regulates the horizontal scope of both the atlas image and the superimposed atlas contours on the patient image.

You can adjust the scaling using the relevant slider. Use the patient images and superimposed contours to correctly adjust local matching of the contours.

Options
To increase the scope, drag the slider to the right.
To decrease the scope, drag the slider to the left.

---

## How to Position Target and Entry Points

Steps
1. Click the <b>Target</b> button, and click directly in either the atlas or patient image to place the point at the desired location.
2. Click the <b>Entry</b> button, and click directly in either the atlas or patient image to place the point at the desired location. The trajectory position is now shown adjusted in the images.



# 16.6 Additional Functions

## Printing the Treatment Plan

### General Information

Once you have completed stereotactic planning, you can generate a printout (PDF) for intra-operative use with the stereotactic system.

### How to Print

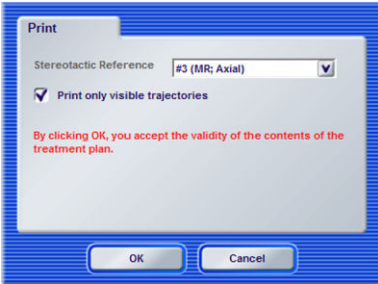
Steps	
1.	 Click the <b>Print</b> button in the toolbar.
2.	 <p>In the <b>Print</b> dialog, select a localized image set from the drop-down list.</p> <p>If you would like to include only visible trajectories in your printout (indicated by an open eye symbol, see page 62), enable the <b>Print only visible trajectories</b> check box.</p>
3.	Click <b>OK</b> to display the generated PDF.

### PDF Dialog

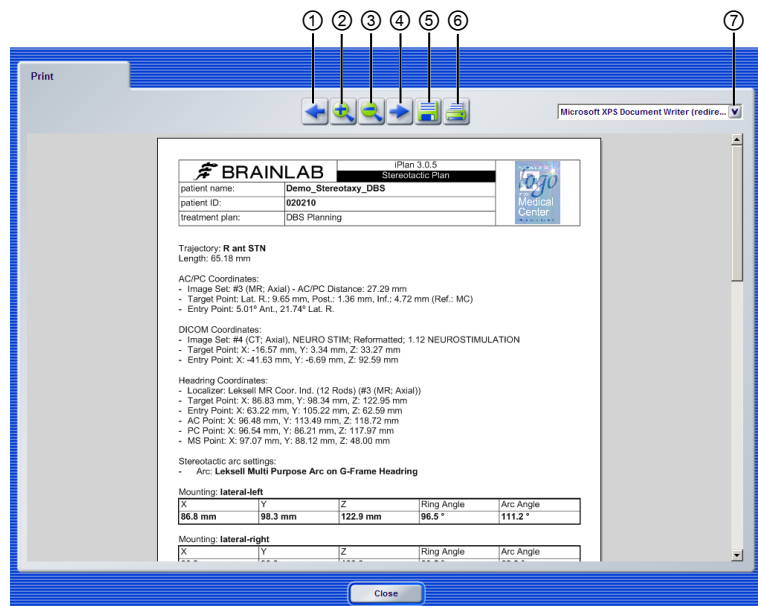

Figure 107

No.	Component
①	Previous page
②	Zoom in
③	Zoom out
④	Next page
⑤	Save
⑥	Print
⑦	Printer selection

### Printed Information

The following information is provided in the PDF:

- The name and length of the trajectory
- Arc settings (if the image sets are localized)
- AC/PC relative coordinates (if the image sets are AC/PC localized)
- Heading coordinates for AC, PC, and MS (mid-sagittal) points (see page 240)

### Safety Notes



**All treatment plan reports must be approved by a qualified person before the information they contain is used for radiotherapy treatment purposes.**



**All printed coordinates are only valid with compatible positioning systems (see page 13).**

### About the MS Point

The MS point is required to define the orientation of the mid-sagittal plane (illustrated below) along the AC/PC axis. The distance from the MS point to the AC/PC is defined as 70 mm.

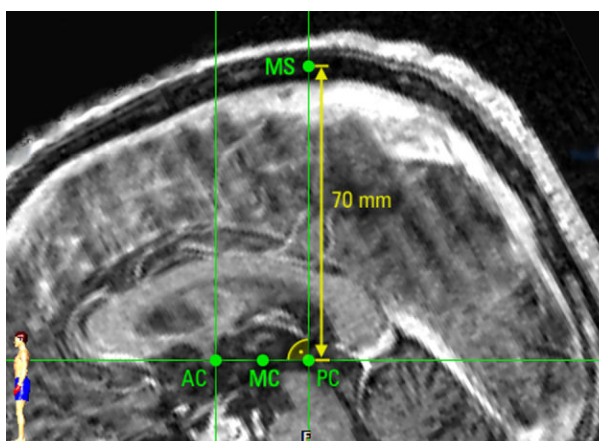

Figure 108

### Stereotactically Localized Image Sets



**If the treatment plan contains multiple fused localized image sets, you can select the preferred localized image to be used as the stereotactic reference. The selected stereotactic reference will be specified on the printout, on the arc settings dialog, and**

**displayed on the measurement coordinate label (see page 235). Before applying arc settings/headring coordinates, verify that the correct stereotactic reference was used (see page 234).**

## 16.6.1 General Functions

### How to Remove Trajectories

Steps	
1.	Select the trajectory from the list.
2.	Click <b>Remove</b> .

### How to Find Target and Entry Points

Steps	
1.	Select the trajectory from the list.
2.	 Click the magnifying glass icon on the <b>Target</b> or <b>Entry</b> button. The relevant point is now shown in the middle of the view.

### How to Display AC/PC Points

If AC/PC localization has been performed in the selected image set, or the selected image set has been fused to an image set that is AC/PC localized, you can display the AC/PC points in the image views.

Step
Enable the <b>Display AC/PC Points</b> check box in the functions area. The points are shown as green spheres in the image views.

### MER/S Data



If you reposition a trajectory, any MER/S data and tracks belonging to that trajectory will not be deleted. The software will display information on changed trajectories and subsequent changes to related tracks in the Plan Content tab where MER/S data is listed.



If you delete a trajectory using the Remove function, any MER/S data entered for the tracks belonging to that trajectory will be lost. Deleted trajectories can be restored using the Undo function.



Once you have entered MER/S data, use extreme caution if you modify or remove trajectories.

*NOTE: For more information on MER/S data, see page 251.*

## 16.7 Trajectory Display and Verification

### Trajectory Display

#### Possible Displays

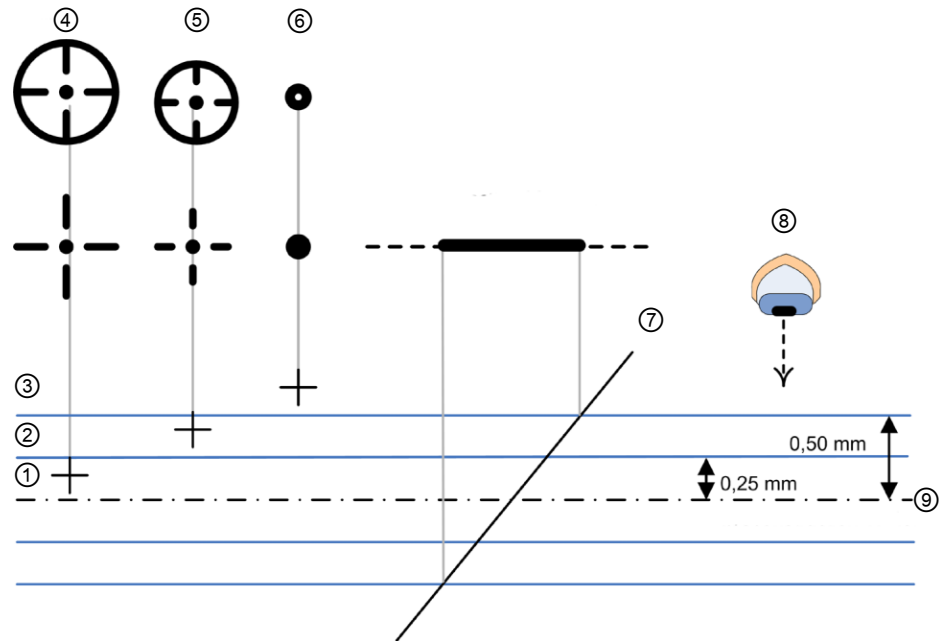

Figure 109

The display of the trajectory target and entry points in the image views are represented by different identifiers, depending on their location relative to the currently displayed slice/ reconstruction.

No.	Point planned
①	In-plane
②	Near-plane
③	Off-plane
④	Full size
⑤	Half size
⑥	Dot
⑦	Trajectory pathway
⑧	View point
⑨	Slice/ reconstruction center

#### Trajectory Indicators



The intersection indicator (emphasized part of the trajectory) is not related to the scan thickness or actual tissue penetration. The actual tissue penetration can be determined using the Probe View.



The diameter displayed for the trajectory represents the intersection of the trajectory cylinder with the current slice/reconstruction.

### Example Displays

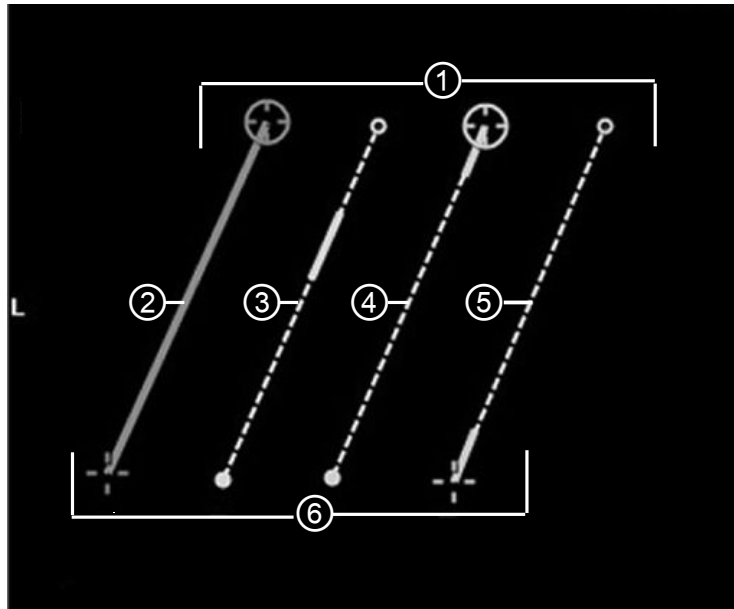

Figure 110

No.	Display	Explanation
①	Entry point	The trajectory entry point
②	Single, thick line	The trajectory target and entry points are located within the displayed slice (i.e., the trajectory lies within the slice plane)
③	Dotted line with thick mid-section	The trajectory passes through the current slice plane, however the target and entry points are located in different slices The thick midsection indicates the point where the trajectory intersects this slice
④	Dotted line with thick tip at entry circle	The trajectory entry point is located in this slice, however the target point is located in a different slice The thick trajectory tip indicates the point where the trajectory intersects this slice
⑤	Dotted line with thick tip at target point	The trajectory target point is located in this slice, however the entry point is located in a different slice The thick trajectory tip indicates the point where the trajectory intersects this slice
⑥	Target point	The trajectory target point

### Trajectories in Image Sets

Each trajectory is linked to the slice set in which the target point is positioned.

You can link a trajectory to a another image set by selecting an image set and relocating the target point to this set.

You can verify to which slice set a trajectory is linked by selecting the trajectory in the **Plan Content** tab and viewing the corresponding properties information displayed on the right side of the tab.



**If you subsequently change the slice set, or alter image fusion after positioning a trajectory, you must verify its accuracy.**

## 16.7.1 Verifying Trajectories

### General Information

The **Probe View** is useful for verifying trajectories. This tab displays image slices from the perspective of the trajectory angle (oblique angle). This allows you to see the entire course of the trajectory and ensure that no critical structures are penetrated.



**All planned trajectories must be verified in the image views, e.g., using the Probe View or Overview tabs.**

### How to Verify Trajectories

Steps	
1.	 Enable the <b>Scrolling</b> button.
2.	Scroll through scan reconstructions along the axis indicated by the patient icon (shown bottom left of the image view). The distance from the view plane to the target point is displayed in the lower right view of the <b>Probe View</b> tab.

*NOTE: You can also verify trajectories using the **Pan and Recenter** button (see page 284).*

### Trajectory Display in the Probe View

The below image provides an example of trajectory verification in the **Probe View** where the trajectory is penetrating a blood vessel.

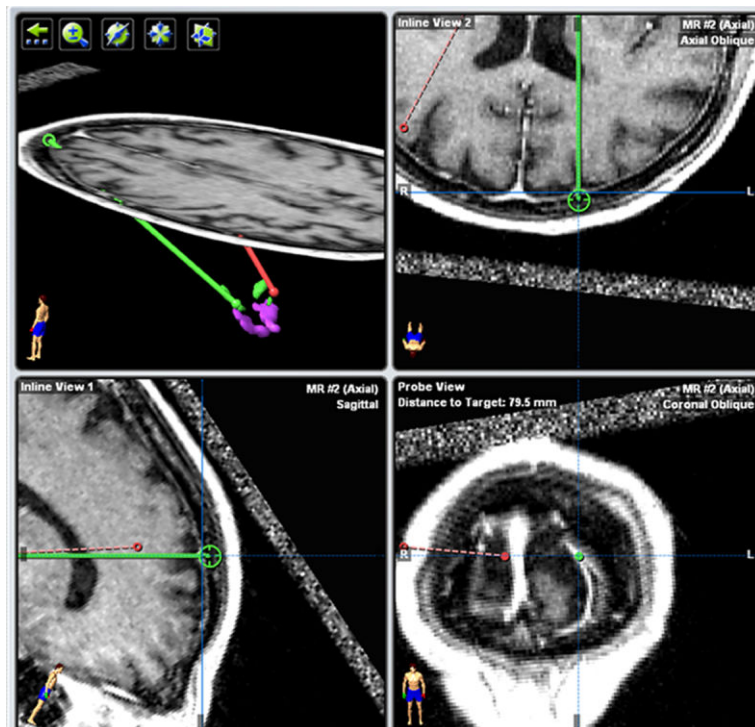

Figure 111



---

**Trajectory Display in a Slice View**

The below image shows the same trajectory as in the previous figure, but planned in the 4 Views tab page. Here it is comparatively hard to detect the trajectory's lateral penetration of the blood vessel.

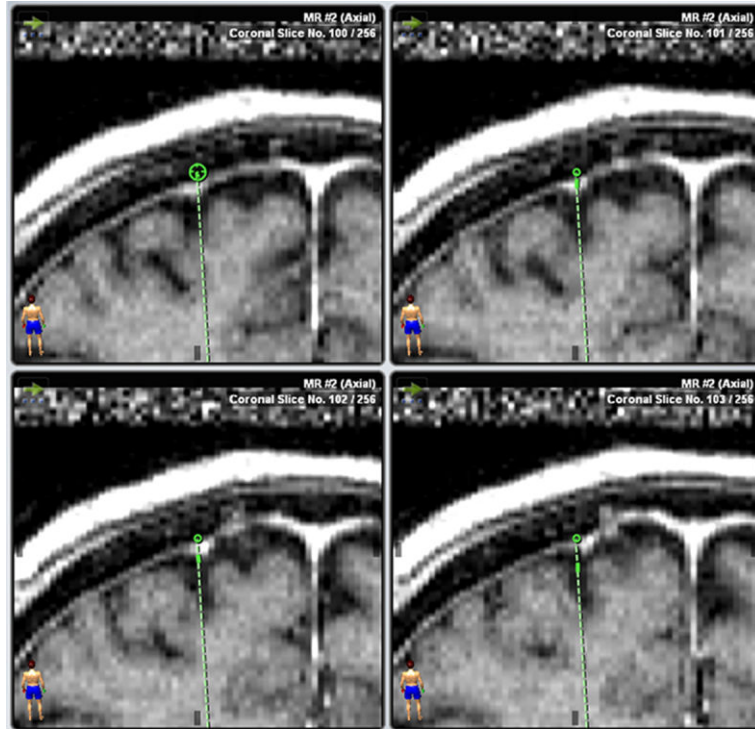

Figure 112



# 17 ELECTRODE RECORDING

## 17.1 Introduction

### Overview

---

#### General Information

The **Electrode Recording** planning task allows you to plan parallel tracks in the image set relative to previously planned trajectories.

Once you have planned one or more parallel tracks, you can view the patient's anatomy (using axial, coronal, sagittal, and probe view reconstructions) relative to given stereotactic positions along the selected track. You can define these stereotactic positions by adjusting the distance values in the software.

You can then enter microelectrode recording and stimulation (MER/S) data measured intraoperatively at a given distance on a specific track.

The entered data is displayed in graphical and anatomical representations on the screen. You can use the displayed information to determine the optimum implant position for electrode placement.

---

#### Before You Begin

Before using **Electrode Recording**, you should have completed all preoperative planning tasks such as stereotactic trajectory planning (see page 229). In particular, a trajectory must be defined, which will be applied to the stereotactic arc.

It is recommended to save a finalized preoperative treatment plan before proceeding with **Electrode Recording**, and then save an intraoperative plan. This allows you to review the procedure in both preoperative and intraoperative states.

## 17.1.1 Electrode Recording Functions

### Main Screen

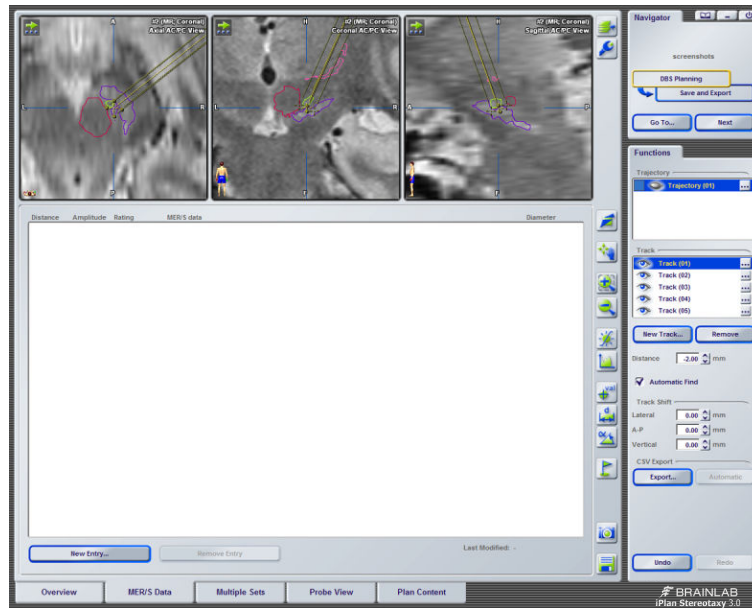

Figure 113

### Available Functions

Function	Explanation	See
Trajectory list box	Lists trajectories that you have added to the image set. From here you can modify the visibility, color and properties of the trajectories.	Page 148
Track list box	Lists tracks that you have added to the image set (parallel to the selected trajectory)	Page 258
New Track...	Add a track	
Remove	Remove a track and any data that has been entered for the track	Page 259
Distance	The current depth position of all tracks	Page 261
Automatic Find	Center the view to the current depth position along the selected track	Page 261
Track Shift	Adjust the track position to compensate for e.g., brain shift	Page 261
CSV Export	Export data to an external folder as CSV file format	Page 271

## 17.2 Planning Parallel Tracks

### Overview

---

#### General Information

Parallel tracks, which represent the actual pathway of the electrode through the tissue during MER/S data acquisition, are required in order to define the exact stereotactic position of the MER/S data that you measure intraoperatively.

You can plan as many parallel tracks as you wish relative to a selected stereotactic trajectory.

Even if you do not wish to use parallel tracks, and intend only use the track represented by the trajectory itself, it is still necessary to define the track represented by the trajectory (the center track).

---

#### Reference for Parallel Tracks

As long as the trajectory you select for track planning is applied to the stereotactic arc system, the arc system which is specifically adjusted for the selected trajectory is considered as the coordinate reference.

The preplanned trajectory is adjusted on the arc system according to the arc settings you defined during stereotactic trajectory planning as described on page 229.

## 17.2.1 Track Planning Relative to the Stereotactic Arc

### Track Coordinates

Parallel tracks can be defined by standard polar (angle and radius) or Cartesian coordinates, which are related to the coordinate reference specified by the software (usually the arc system defined by the stereotactic reference).

### Track Angle Definition

Depending on the arc system you are using, the orientation and zero position engraved on the stereotactic arc varies. When planning parallel tracks, you must consider the same orientation (zero position and angle counting direction) as shown in the figure below.

This position always corresponds to a theoretical left to right mounted stereotactic arc device.

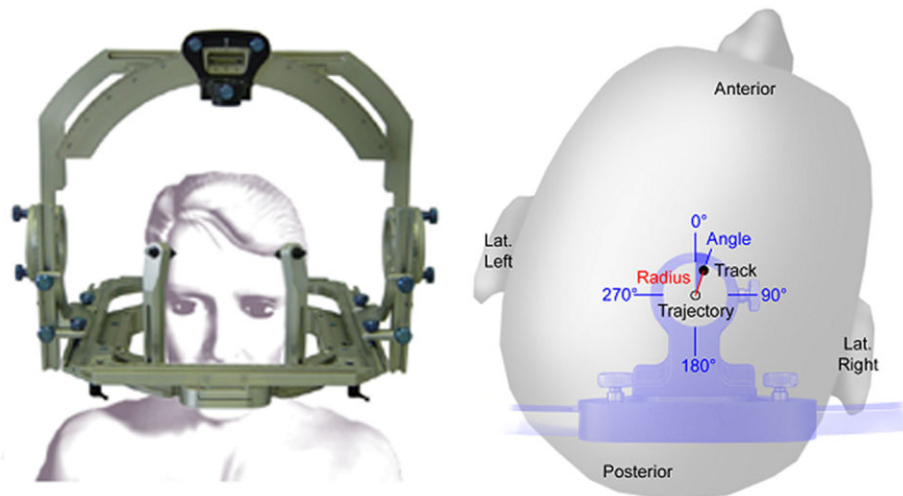

Figure 114



**It may happen that the zero mark and angle counting direction engraved on the stereotactic arc does not fit to the zero mark and angle counting direction shown in the illustration. When using the Electrode Recording planning task, always use the orientation shown in Figure 114.**

### Verifying the Position



**The adjusted stereotactic arc has a major impact on the track definition. Once you have planned a parallel track, use the Probe View and the Overview tabs to verify the defined track relative to the patient's anatomy and the entered track coordinates (see page 260).**



**Verify the angle, radius and reference definition for each track when entering or modifying the parallel track. Otherwise, the track may be displayed incorrectly, or not as expected, relative to the anatomical data in the image views.**



**If you change an image fusion, stereotactic localization or AC/PC localization, always verify the position of the parallel tracks you have planned in the properties dialog (see page 258) before adjusting them to the arc system.**

## 17.2.2 Applying Planned Tracks to the Arc System

### General Information

The preplanned angle definition and radius of the parallel tracks are used to adjust the microdrive mounting in order to optimize the resulting track orientation.

Because the settings displayed in the software during planning are based on standard polar coordinates (in order to support all available microdrives), the individual track adjustment parameters for a specific microdrive must be recalculated by the user (see page 255).

### Orientation of the Microdrive

In order to accurately adjust the planned tracks on the arc system, consider the axial orientation of the microdrive ① mounted on the arc system as in the image below.

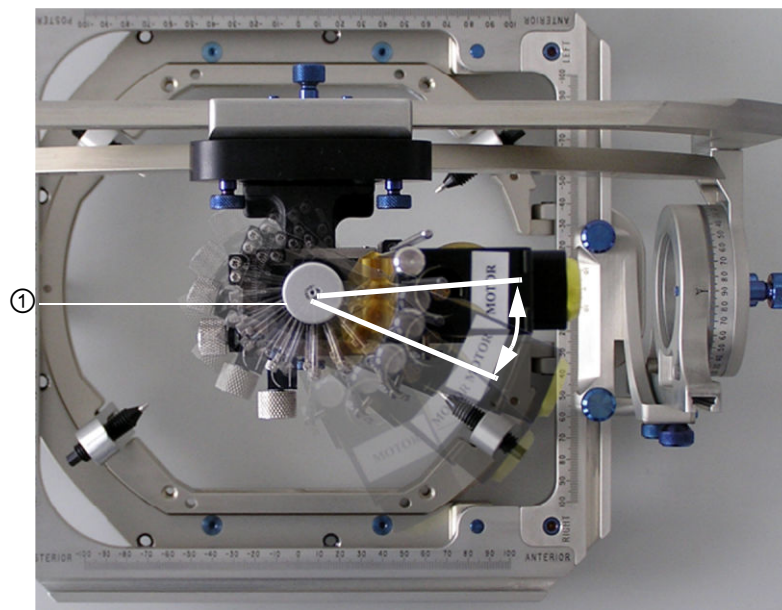

Figure 115

*NOTE: Use the **Probe View** to plan and verify the orientation of the microdrive.*

### Microdrive Adjustment Capabilities

Common microdrives normally have a predefined configuration of parallel tracks. For example:

- A "Ben Gun" multi-track device which can be mounted in the "x" (=45°) or "+" (=0°) orientation
- An x/y table adjustment for parallel tracks
- A combination of both adjustment capabilities

The below image provides an example microdrive with combined adjustment capabilities.

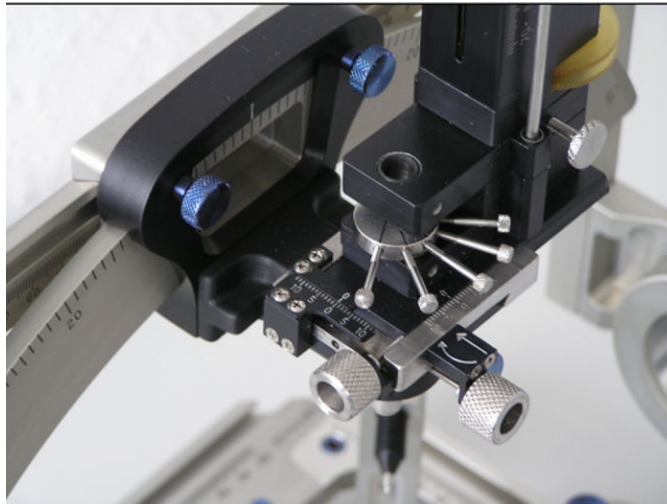

Figure 116



**Verify you have adjusted the tracks considering the correct coordinate reference, zero mark, counting orientation and microdrive mounting orientation relative to the individual arc system. Otherwise, the tracks and all Electrode Recording Planning results will be displayed incorrectly relative to the anatomical position. This may lead to an incorrect treatment decision resulting in severe patient injury.**

**Coordinate References for Parallel Tracks**

Coordinate Reference	Explanation
Stereotactic reference	<p>If the selected trajectory is defined in an image set that is the stereotactic reference (or in an image set that is fused to the stereotactic reference), the stereotactic reference is used as the coordinate reference for track planning.</p> <p>In this case, the surgeon can apply the planned tracks based on the orientations defined by the arc system (as illustrated on the previous page).</p>
Image Set Coordinates	<p>If the selected trajectory is defined in an image set that is not the stereotactic reference (and not in an image set fused to the stereotactic reference), the image set coordinate system is used as the coordinate reference for track planning.</p> <p>In this case, the surgeon must manually define the position and orientation of the frameless positioner relative to the patient in order to apply the planned tracks to the patient.</p>



**Make sure to verify the coordinate reference in order to avoid applying the track coordinates based on an incorrect coordinate reference.**

**Example Track Coordinates (Based on Arc System)**

Bilateral approach with five parallel tracks per trajectory (“Ben Gun” approach, “+ mount”):

Example Trajectory Name	Track Name	Polar Coordinates	Cartesian Coordinates
STN Right	Center	Radius: 0.00 mm Angle: 0.00°	x: 0 mm y: 0 mm



Example Trajectory Name	Track Name	Polar Coordinates	Cartesian Coordinates
	Anterior	Radius: 2.00 mm Angle: 0.00°	x: 0 mm y: 2
	Posterior	Radius: 2.00 mm Angle: 180.00°	x: 0 mm y: -2 mm
	Medial	Radius: 2.00 mm Angle: 270.00°	x: -2 mm y: 0 mm
	Lateral	Radius: 2.00 mm Angle: 90.00°	x: 2 mm y: 0 mm

*NOTE: The reference in this example is the arc system.*

---

### Invalid Track Positions

For trajectories that are colinear to the lateral vector of the coordinate reference, the 0° direction used for track definition is undefined. For such trajectories, it is not possible to create, modify, or visualize tracks. In this case, you can slightly change the trajectory, or use an alternative trajectory.

### 17.2.3 Planning New Tracks

#### How to Select the Image Set and Trajectory

Steps	
1.	 <p>Click the <b>Slice and Image Set Selection</b> button and select the image set that contains the required trajectories.</p> <p><i>NOTE: If image sets are not fused, make sure to select the image set which contains the desired trajectory. Otherwise, the trajectory will not appear in the list.</i></p>
2.	Select the relevant trajectory from the list in the functions area.
3.	<p>Click <b>New Track...</b></p> <p>The <b>Properties</b> dialog opens in which you can define coordinates for the tracks.</p>



**Make sure to select the correct trajectory for track definition. Only the trajectory applied to the stereotactic arc system (or frameless positioner) can be used as the basis for planning tracks and entering MER/S data. An incorrectly selected trajectory may lead to incorrect anatomical correlation when viewing the MER/S data!**

#### How to Add Tracks

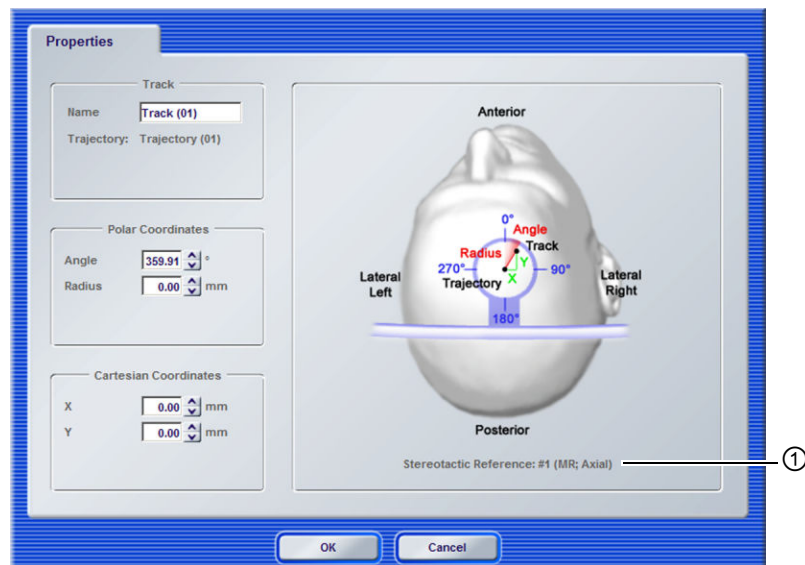

Figure 117

Steps	
1.	In the <b>Properties</b> dialog, enter a name for the track in the <b>Name</b> field. For example: Center (track that represents the pathway of the actual trajectory), anterior, posterior, medial, lateral, etc.
2.	<p>Enter the coordinates in the fields provided. You can define either polar or Cartesian coordinates.</p> <p><i>NOTE: Coordinates for the center track should remain "0" as this track represents the actual trajectory. Example track coordinates are provided on page 256.</i></p>

Steps	
	Verify that the reference for the track shown in the dialog is <b>Stereotactic Arc System</b> . <i>NOTE: If the selected image set is not stereotactically localized or fused to a stereotactically localized image set, the reference is shown as <b>AC/PC Coordinate System</b> (if the image set is AC/PC localized or fused to an image set which is AC/PC localized). If the image set is neither stereotactically nor AC/PC localized, the reference is shown as <b>Image Coordinate System</b> (see page 256).</i>
3.	
4.	Click <b>OK</b> to confirm your settings and add the track to the track list in the functions area.

---

### How to Modify Tracks

Once you have created a track, you can modify it at any time.

Step	
	Click the properties icon next to the track in the list to open the <b>Properties</b> dialog, and change the track coordinates as required.

---

### How to Remove Tracks

Steps	
1.	Select the track from the list.
2.	Click <b>Remove</b> .



If you remove a planned track, all previously entered data for the track may be lost.

## 17.2.4 Verifying Tracks

### General Information

Once you have planned tracks, you should verify the position of the tracks relative to the actual anatomy in the **Probe View** and/or **Overview** tabs.

In these tabs, you can visualize the entire pathway of the tracks to ensure that no critical structures are penetrated.



Verify the anatomical position of all planned parallel tracks in order to avoid vessel injury and inefficient or incorrect pathways through the tissue. Verify all planned tracks before adjusting the planned arcs on the arc system in preparation for patient treatment.



Changes to the treatment plan (AC/PC Localization, stereotactic localization(s) or image fusion(s), trajectory positions) may cause unexpected changes to track information, including MER/S data. Make sure to verify the anatomical position of the track in anatomical views, as well as track coordinates in the Properties dialog (see page 258), before implanting the electrode or making any clinically relevant conclusions based on the provided track information.

### Displayed Tracks

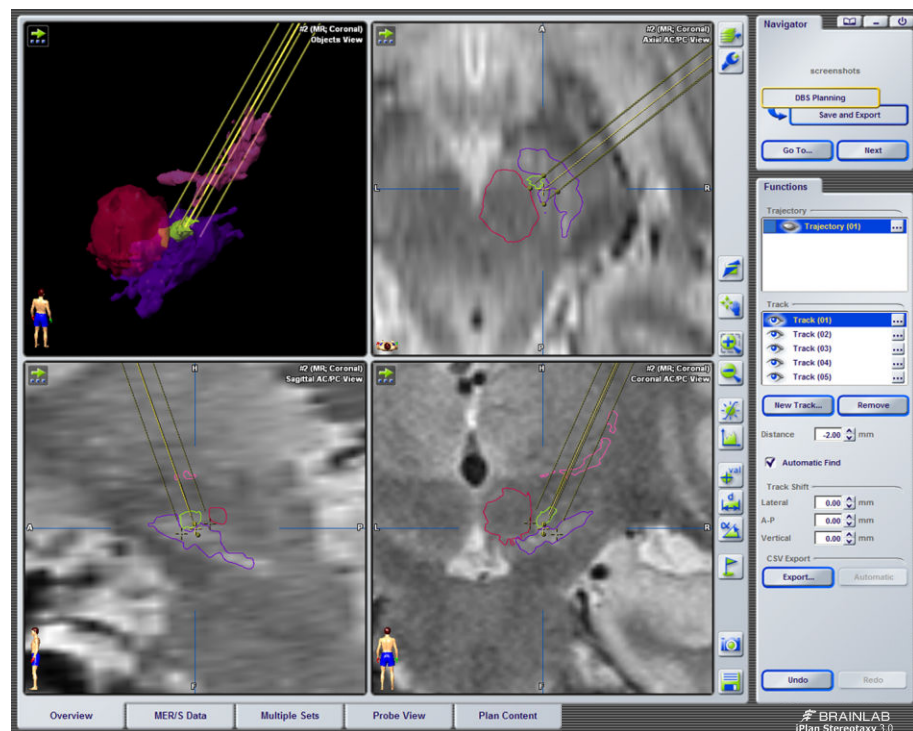

Figure 118



The track and trajectory currently selected from the **Track** list in the **Functions** area are highlighted in yellow in the image views.

*NOTE: To best verify the track positions in the image views, you should hide the corresponding trajectory by clicking the eye button to close it.*

## 17.2.5 Track Display and Position

### Track Depth Position

The track distance indicates the current position for the selected track. The position is indicated as follows:

Depth Position Display	
	If the current view is in-plane with the current depth position of the selected track, the track position is indicated by a comparatively large cross
	If the current view is close to the current depth position of the selected track, the track position is indicated by a comparatively small cross
	If the current view is not in-plane with the current depth position of the selected track, the track position is indicated by a circle

### How to Adjust the Depth Position

You can adjust the depth position of the tracks in order to define the position where the MER/S data is to be entered, and to better visualize the pathway through the tissue.

Step
In the <b>Distance</b> field in the functions area, click the arrow buttons, or enter the value in the field. The displayed depth position of all tracks is adjusted accordingly in the image views.

### How to Center the View to the Track Depth Position

When the **Automatic Find** checkbox in the functions area is enabled, the image views will automatically center to the current depth position of the selected track each time you adjust the depth position of the track.

### How to Shift Tracks

You can use the **Track Shift** options in the functions area to reposition tracks in order to e.g., compensate for brain shift (if the intraoperative situation no longer matches the image data acquired preoperatively).

Step
In the <b>Track Shift</b> fields, click the arrow buttons, or enter the value in the field to adjust the track in the corresponding direction (lateral, anterior-posterior, and vertical). All tracks associated with the selected trajectory shift accordingly. The trajectory position does not change.

### Track Intersection Indicators

An intersection indicator is also shown for each track. The indicators display the intersection between the track and the currently displayed viewing plane.

The track display varies depending on whether the entire track is located in the same view plane, or whether the track extends over several slices.

The intersection indicators have the same display convention as for the stereotactic trajectories (see page 239).



**Do not confuse the intersection indicator with the current depth position indicated by the cross. If in doubt, use the Automatic Find function to center all views relative to the currently selected track and current depth position.**

## 17.3 Entering MER/S Data

### Overview

---

#### General Information

Once parallel tracks have been planned in the software, you can intraoperatively enter microelectrode recording data obtained along the planned tracks at varying depths directly in **iPlan**.

---

#### MER/S Data Types

You can enter data for the following categories:

- Comment
  - Positive effect
  - Negative side-effect
- 

#### Comments

A comment can be a single data entry (obtained during microrecording) related to a certain position on a planned track, which provides any type of descriptive information.

Comments can be used, e.g., to describe the analyzed pattern of the recorded neuronal activity. For example, “regular burstic activity” might be entered if the recording signal shows regular burstic activity.

Comments can also be used to describe the behavior of the patient during the stimulation measurements. For example, “very nervous patient, unreliable result” might be entered, if the patient does not cooperate very well or is too nervous to provide reliable results.

In this case, the surgeon can later decide what to do with the measured results.

---

#### Positive and Negative Effects

You can enter data based on results obtained during intraoperative stimulation at a specified stimulation amplitude related to a certain position on a planned track. You can classify such entries according to whether a positive or negative effect was noted. You can use this type of data as distinct and quantitative information (criteria) for qualifying or disqualifying the measured position for the final electrode placement.

- A positive effect is defined as a “desired” effect on the patient (such as arm movement in a patient with rigidity) resulting from the stimulation
  - A negative effect is defined as an “undesired” effect on the patient resulting from the stimulation
- 

#### Amplitude Settings

A valid stimulation amplitude unit is defined in **iPlan** according to clinician preference. If a change to the unit is required, contact Brainlab support.

## 17.3.1 Entering Data

### How to Access MER/S Data Entry

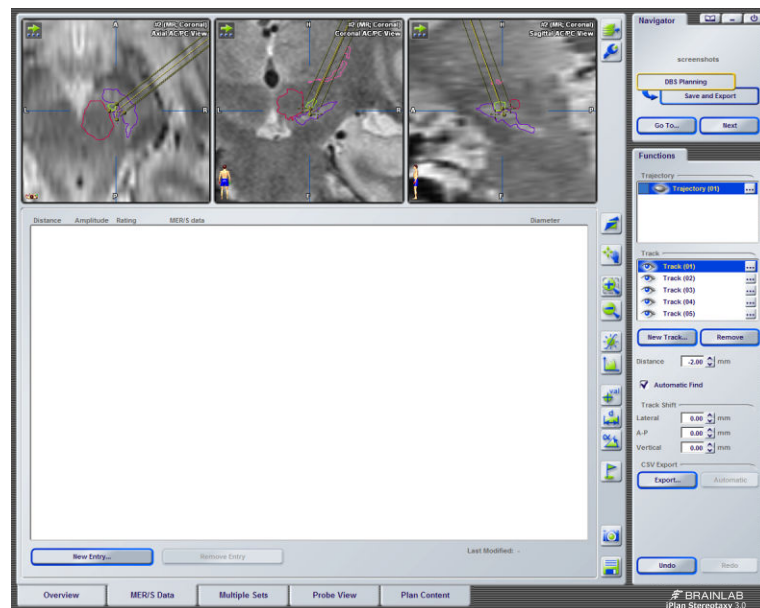

Figure 119

Steps	
1.	Open the <b>MER/S Data</b> tab.  From the trajectory list, select the trajectory which is currently applied to the stereotactic arc system (the adjusted stereotactic arc as mounted on the patient heading intraoperatively).
2.	<i>NOTE: Trajectories that do not belong to the selected image set (or to other image sets that are fused to it) are not listed in the trajectory list. It may be necessary to first select the relevant image set (see page 258).</i>
3.	From the track list, select the track for which you would like to enter data.
4.	Click the <b>New Entry...</b> button. The <b>Properties</b> dialog opens.



## Properties Dialog

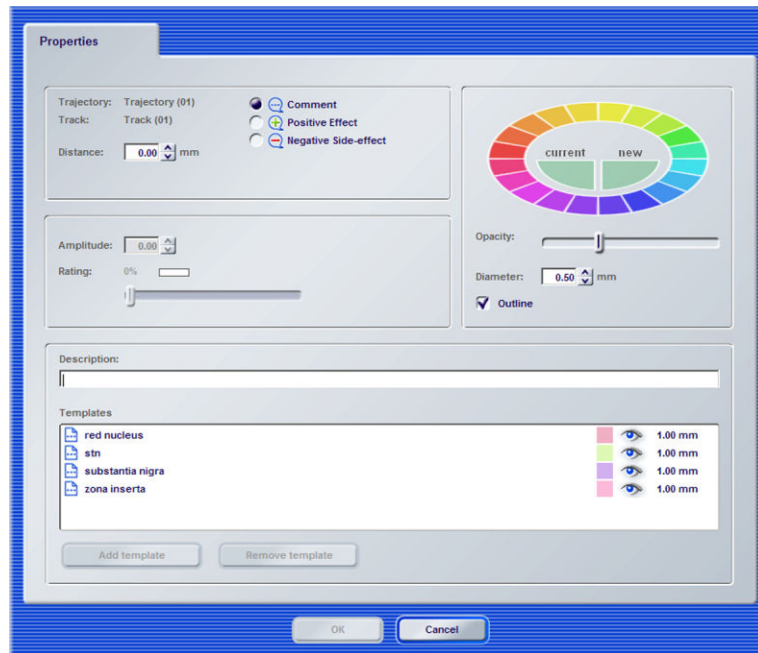



Figure 120

You can now enter comment, positive effect, or negative side-effect data related to specified positions on the selected track. The data types are described on page 263.







**Before entering data in the Properties dialog, verify the selected trajectory and track name shown in the dialog to ensure that your selection is correct.**

## How to Enter Comments

Steps	
1.	 Select <b>Comment</b> .
2.	In the <b>Distance</b> field, click the arrow buttons, or enter the value in the field to define the track position for which the comment is relevant.
3.	Enter a name or description for the comment in the <b>Description</b> field, or select an already entered name from the <b>Template</b> list (see page 269).
4.	The comment will be represented as a sphere at the indicated track position in the image views. <ul style="list-style-type: none"> <li>• From the color palette, select a color for the sphere.</li> <li>• Use the slider bar to adjust opacity of the sphere in the image views.</li> <li>• In the <b>Diameter</b> field, click the arrow buttons, or enter the value in the field to define the sphere diameter.</li> <li>• Enable the <b>Outline</b> check box to show the sphere outlined with the selected color.</li> </ul>
5.	Click <b>OK</b> to enter the comment and close this dialog.

### How to Enter Positive Effects and Negative Side-Effects

You can enter data based on results obtained during intraoperative stimulation at a specified stimulation amplitude, and classify such entries according to whether a positive or negative effect was noted.

Steps	
	Depending on the effect, select:
1.	<div style="text-align: center;"></div> <p><b>Positive Effect</b> (indicates a suitable position for final electrode placement)</p> <div style="text-align: center;"></div> <p><b>Negative Side-effect</b> (indicates an unsuitable position for final electrode placement)</p>
2.	Enter a name or description for the effect in the <b>Description</b> field.
3.	In the <b>Distance</b> field, click the arrow buttons, or enter the value in the field to define the track position for which the effect is relevant.
4.	In the <b>Amplitude</b> field, click the arrow buttons, or enter the stimulation amplitude value at which the effect was obtained.
5.	<p>Use the <b>Rating</b> slider bar to define the strength of the effect. Dragging the slider bar to the right represents a stronger effect. Dragging the slider bar to the left represents a milder effect.</p> <div style="text-align: center;">  </div> <p><b>Positive Effects:</b> Slider bar is shown in green</p> <div style="text-align: center;">  </div> <p><b>Negative Side-effects:</b> Slider bar is shown in red</p>
6.	<p>The result will be represented as a sphere at the indicated track position in the image views.</p> <ul style="list-style-type: none"> <li>• From the color palette, select a color for the sphere.</li> <li>• Use the slider bar to adjust opacity of the sphere in the image views.</li> <li>• In the <b>Diameter</b> field, click the arrow buttons, or enter the value in the field to define the sphere diameter.</li> <li>• Enable the <b>Outline</b> check box to show the sphere outlined with the selected color.</li> </ul>
7.	Click <b>OK</b> to enter the effect and close this dialog.

### Adding Entries for Other Tracks and Trajectories

You can enter as much MER/S data as you like for a track at varying positions and stimulation amplitudes. You can also use the templates for entering data (see page 269).

- To add data to other tracks belonging to the same trajectory, select the track and repeat the steps above.
- To enter data for tracks belonging to another trajectory (due to the setup or the procedure), first select the trajectory, and then repeat the steps above.

### 17.3.2 Viewing Displayed MER/S Data

#### General Information

All MER/S data that you entered (comments, positive effects and negative side-effects) are now shown in the **MER/S Data** tab.

You can use the displayed information to determine a suitable position for the placement of the electrode by analyzing the MER/S data you entered.

Additionally you can use the information to evaluate the tracks that you planned (page 258). If the tracks do not provide a suitable implant position, planning of alternative tracks may be necessary.

#### MER/S Data Tab

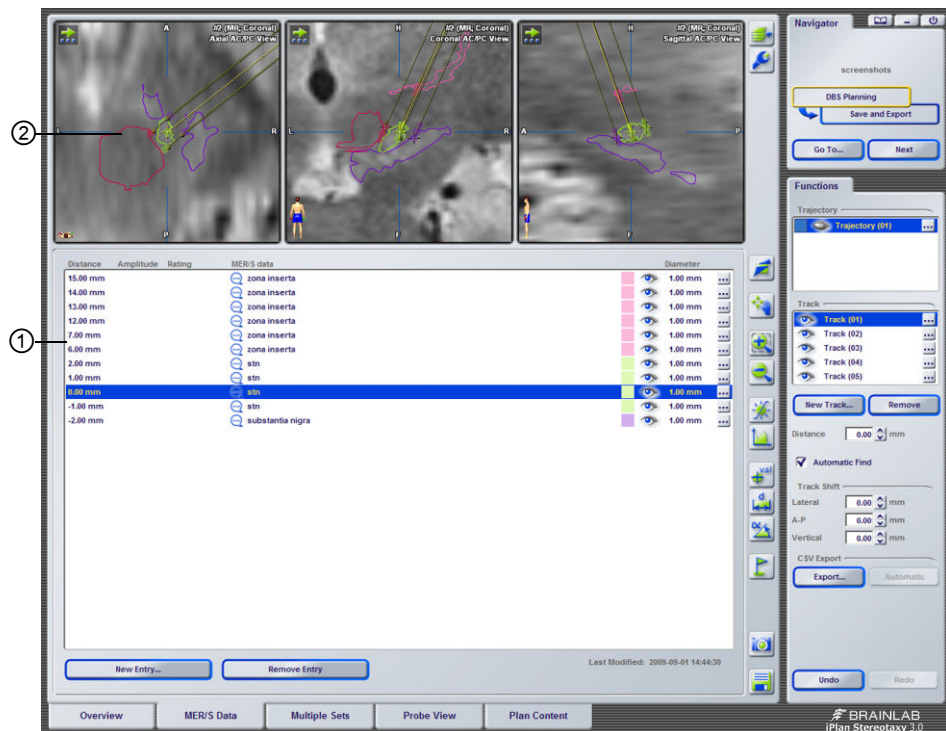



Figure 121

#### Screen Explanation

No.	Explanation
①	 <p>The list view shows all entered MER/S data and corresponding settings defined in the <b>Properties</b> dialog.</p> <p>Click the properties icon next to a list entry to open the <b>Properties</b> dialog, and change settings as required.</p>
	 <p>Click the eye symbol to hide the colored sphere representing the corresponding data entry in the image views.</p>
②	<p>The image views display each MER/S data entry (indicated by spheres according to the color you defined) along the selected track at the defined location. Each sphere corresponds to the listed entries in ①. You can use the image views to review MER/S entries relative to anatomical data.</p> <p><b>NOTE:</b> To view MER/S data in larger views, you can also switch to e.g., the <b>Overview</b> or <b>Probe View</b> tabs.</p>

## Electrode Recording Results in Overview Tab

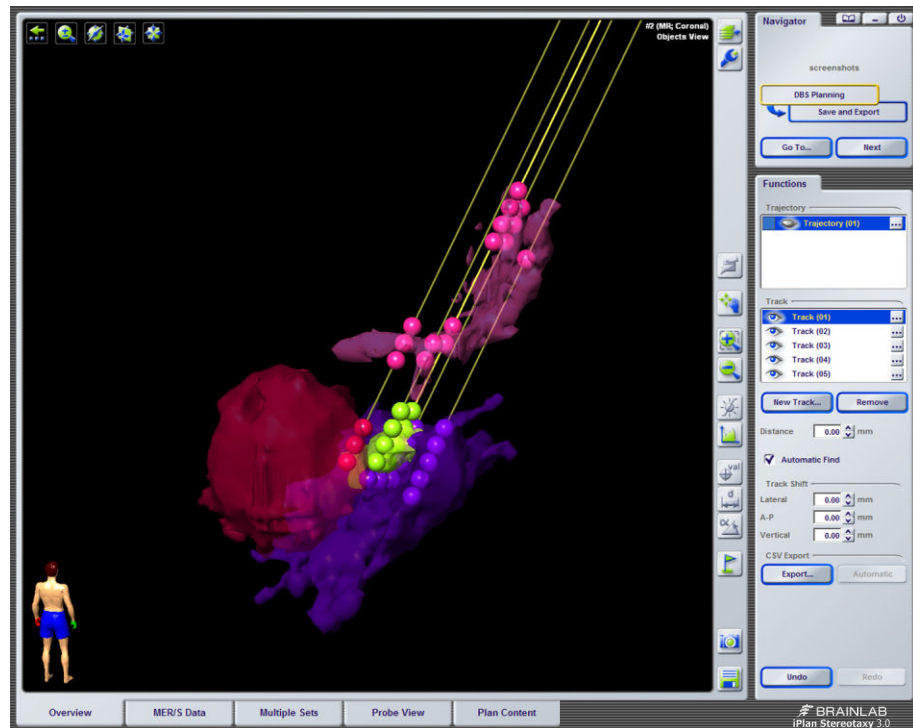

Figure 122

## Selecting MER/S Data Entries

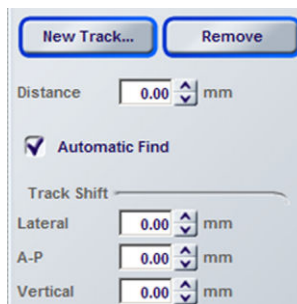

Figure 123

The distance value (indicating the current depth position along the track) shown in the functions area corresponds to the data entry currently selected in the list. When you select an individual entry from the list in the **MER/S Data** tab:

- The distance value updates according to the selected entry
- The image views are centered to the sphere representing the selected entry (when the **Automatic Find** check box is enabled)

## How to Delete Entries

Steps	
1.	Select the MER/S data entry from the list.
2.	Click <b>Remove Entry</b> .

### 17.3.3 Working with Templates

#### General Information

Each MER/S data entry (see page 265) is added to the **Templates** list in the **Properties** dialog. The templates are available in the list for the treatment plan in which you are currently working. You also have the option of adding permanent templates to the **iPlan** application to be available in treatment planning for any patient. This is useful if you enter standard MER/S data into many treatment plans.

#### Templates List

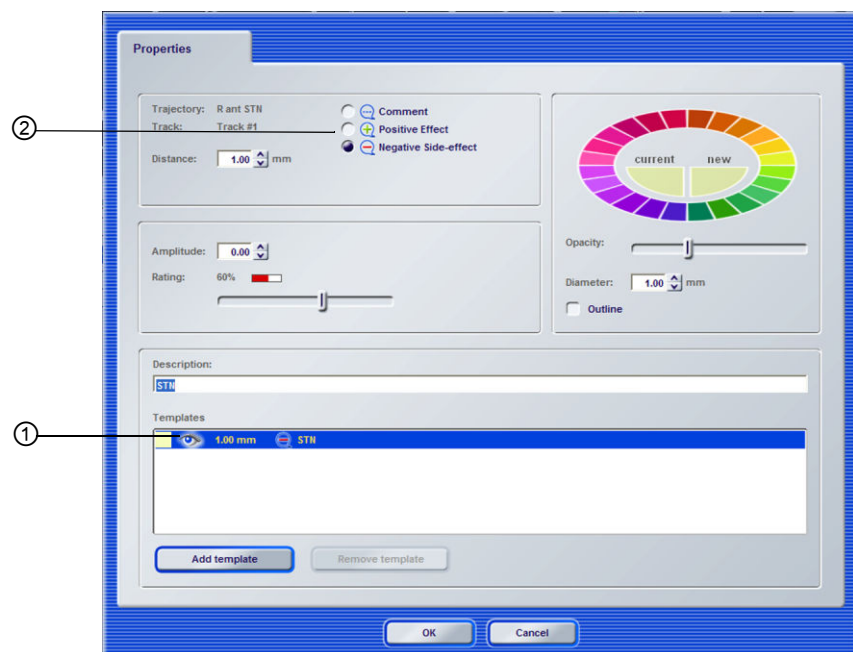

Figure 124

When you add a MER/S data entry, the entry is shown in the **Templates** list ① the next time you open the **Properties** dialog. These entries are relevant only for the selected treatment plan. Only the same types of MER/S data entries are listed together. This means e.g., that all of the MER/S data entries that you classified as a **Comment** are listed together. The data type in the list depends on your selection in ②.







#### How to Add a Permanent Template

Steps	
1.	Enter a name for the template in the <b>Description</b> field, or select an existing entry from the <b>Templates</b> list.
2.	Define all settings for the template (e.g., distance, color, amplitude when relevant).
	Click <b>Add template</b> .
3.	The new template now appears in the <b>Templates</b> list. The relevant icon is shown as a file icon (see table below). This template will be available in every treatment plan that you open with the <b>iPlan</b> software.

**NOTE:** Adding a template does not necessarily mean the MER/S data entry is included in the treatment plan. To include it, make sure the defined settings are correct and then click **OK** in the **Properties** dialog. The entry will be shown in the list in the **MER/S Data** tab.

### Template Symbols

The symbols next to each entry in the **Templates** list indicates whether the entry is available only in the current treatment plan or as a permanent template.

Symbols	MER/S Data Type	Explanation
	Comment	Available only in current plan
	Comment	Available as a template
	Positive effect	Available only in current plan
	Positive effect	Available as a template
	Negative side-effect	Available only in current plan
	Negative side-effect	Available as a template

### How to Remove a Permanent Template

Steps
1. Select the template from the list.
2. Click <b>Remove template</b> .

### 17.3.4 MER/S Data Backup

#### General Information

In order to keep intraoperatively acquired MER/S data accessible after a system crash, you can save the MER/S data as a text file in a chosen directory e.g., on a USB flash drive or a client computer hard drive (if **iPlan Net** is used). In the event of a system crash, the text file can be opened without **iPlan**, using a basic text editor provided by the operating system on an alternative computer platform.



**The backup feature should always be used in order to prevent permanent loss of intraoperatively acquired data due to a system crash.**

#### How to Back Up Data

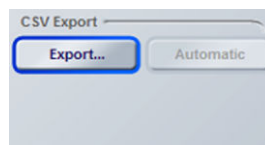

Figure 125

The backup feature is activated via the **CSV Export** section of the functions area.

Steps	
1.	To activate data back up, click <b>Export....</b>
2.	In the <b>Browse</b> dialog that opens, select the folder in which to save data. <i>NOTE: The software tests the connection and displays a message if the path is invalid.</i>
3.	Click <b>OK</b> to close the <b>Browse</b> dialog.
4.	Click <b>Automatic</b> to save data automatically.

#### Saved Data

The following data will be saved:

- Patient name and ID
- Treatment plan name
- Stereotactic reference (image set and stereotactic localizer)
- Stereotactic coordinates for AC, PC and MS (if AC/PC localization exists in the group of fused sets which contain the stereotactic reference)
- Track name
- Parent trajectory name
- Track coordinates (target and entry)
- MER/S data (including data type, distance, amplitude, description, rating, color, visibility, opacity, and contour)
- Application name
- Time stamp
- Checksum





# 18 TOOLBAR FUNCTIONS

## 18.1 Introduction

### Overview

---

#### General Information

The toolbar (located to the right of the planning area) provides general functions that can be used when creating a treatment plan.

Availability of toolbar buttons depends on the current task, and the type of scan image displayed.

---

#### Activating Toolbar Functions

Once you click a toolbar button to activate the corresponding function, the button is shown yellow. Inactive buttons are shown blue.

*NOTE: A toolbar button may be shown grayed out e.g., if it is not applicable for the loaded data.*

## 18.2 Selecting an Image Set

### Overview

#### General Information

The slice and image set selection function allows you to select the image data to be displayed in the image views.

#### How to Access Selection

Step	
	Click <b>Slice and Image Set Selection</b> . The <b>Set Selection</b> dialog opens.

#### Set Selection Dialog

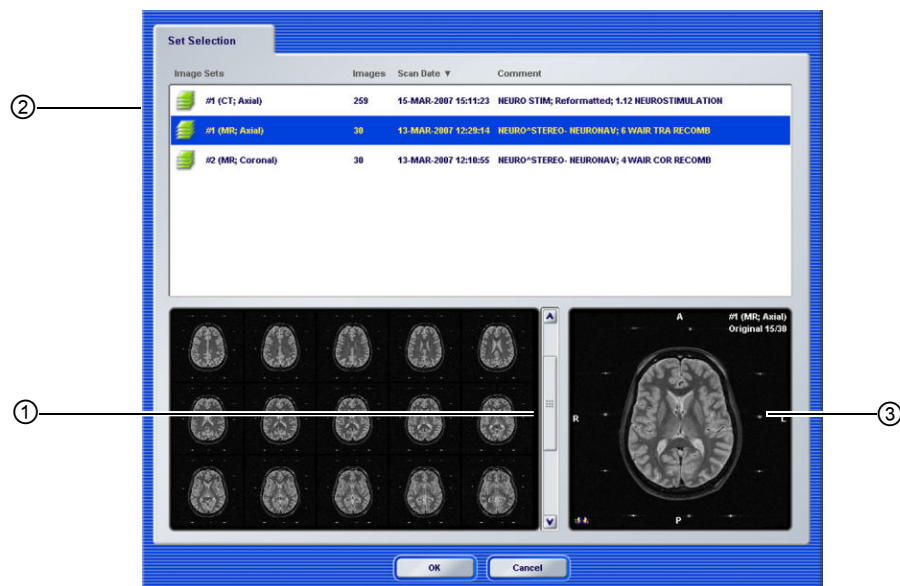

Figure 126

#### How to Select Images

Steps	
1.	From the list of available image sets ②, select the image set to be displayed. To view the available image slices, use the scroll bar in the left view ①.
2.	You can also place the mouse pointer in the right image view ③ to scroll through individual slices.
3.	Click <b>OK</b> to confirm your selection and display the slices in the image views in the planning area.

# 18.3 General Options

## Overview

### General Information

The **Options** function allows you to adjust the display and orientation of the images that are displayed in the image views.

### How to Access View Options

<b>Step</b>	
	Click <b>Options</b> to open the viewing options tabs.

### Options Tabs

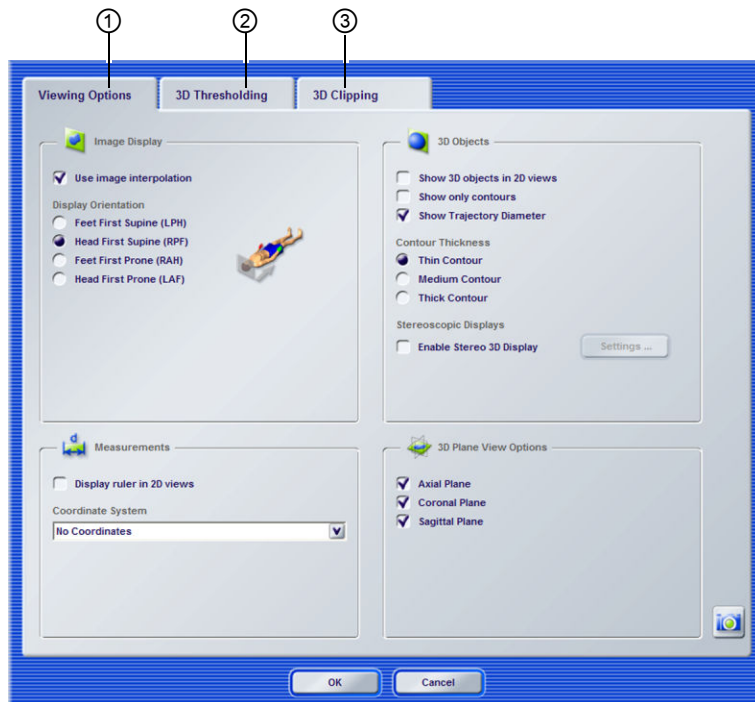

Figure 127

No.	Tab	See
①	Viewing Options	Page 276
②	3D Thresholding	Page 280
③	3D Clipping	Page 281

*NOTE: The availability of the tabs depends on the planning task you are in.*

### 18.3.1 Viewing Options

#### Viewing Options Tab

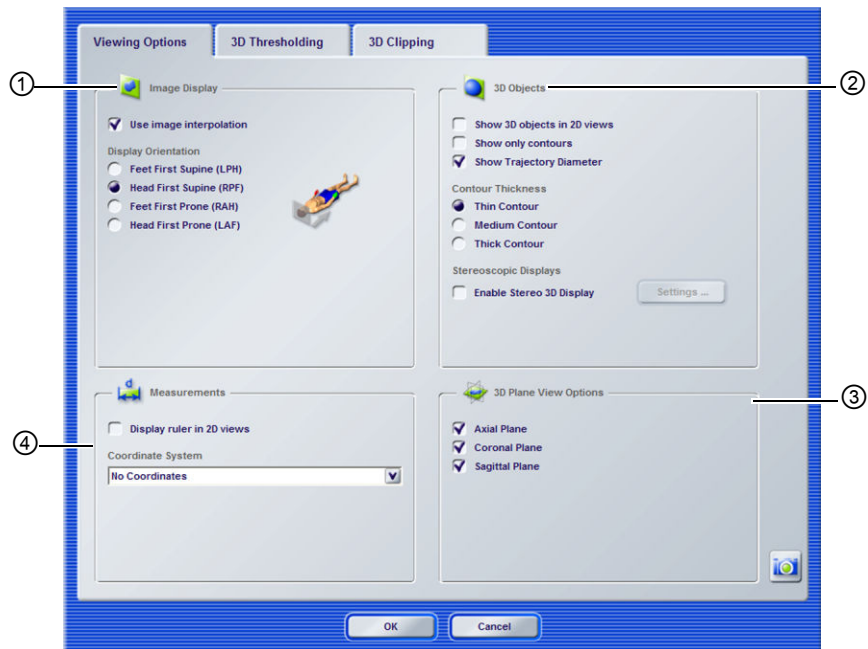

Figure 128

No.	Option	See
①	Image Display	Page 276
②	3D Objects	Page 277
③	3D Plane View Options	Page 277
④	Measurements	Page 278

#### Image Display

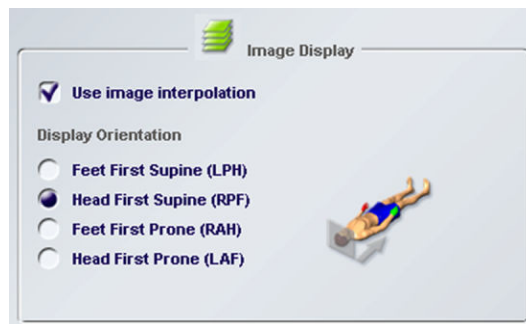

Figure 129

Options
When <b>Use image interpolation</b> is activated, the software interpolates the pixels of the scan images, resulting in an improved image display.
From the <b>Display Orientation</b> options, choose the orientation that you prefer to work with, or the image orientation that matches the planned orientation of the patient on the operating table.

3D Objects

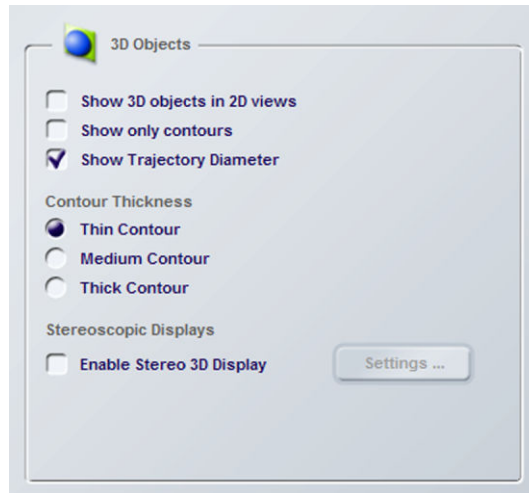
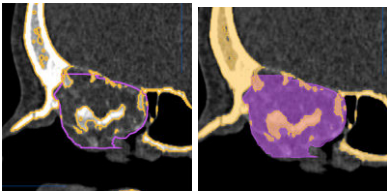

Figure 130

Options	
<p>Select <b>Show 3D objects in 2D views</b> to enable the display of objects (e.g., created with the <b>Object Creation</b> planning task) three-dimensionally in 2D views.</p>	
	<p>Select <b>Show only contours</b> to show 3D objects as out-lines only (left image). When deactivated, 3D objects are shown filled in (right image).</p>
<p>Select <b>Show Trajectory Diameter</b> to display the trajectory according to the diameter defined during trajectory planning (see page 231).</p>	
<p>Select from the following <b>Contour Thickness</b> options to define the width of object contours:</p> <ul style="list-style-type: none"> <li>• <b>Thin Contour</b></li> <li>• <b>Medium Contour</b></li> <li>• <b>Thick Contour</b></li> </ul>	

3D Plane View Options



Figure 131

Select from the following options to display the corresponding plane in 3D views:

- **Axial Plane**

- Coronal Plane
- Sagittal Plane

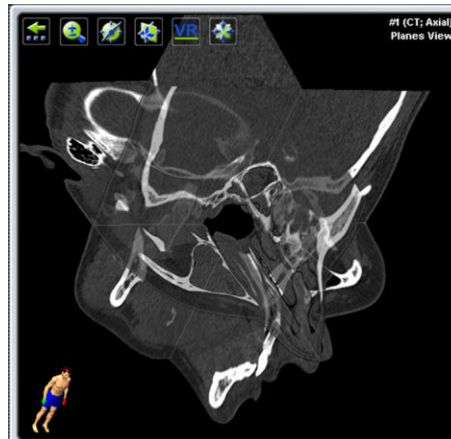

Figure 132



*NOTE: To see the results, make sure that **Planes** is activated via the **View Types** button (see page 77).*

### Measurements: Display Ruler

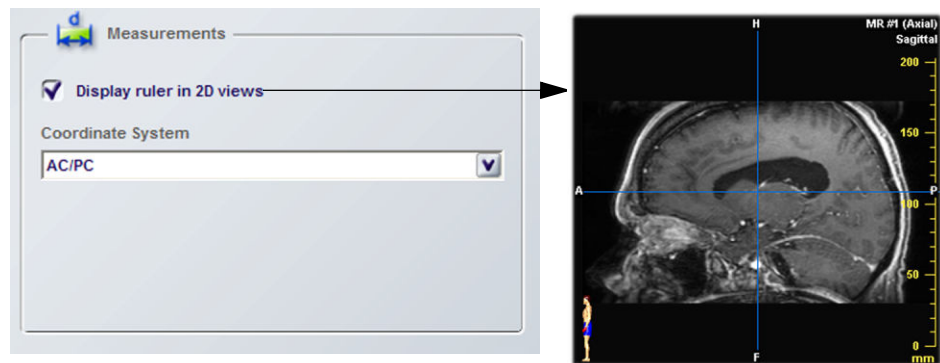

Figure 133

#### Step

Select **Display ruler in 2D views** to activate a scale (in millimeters) on the right side of axial, coronal, and sagittal image views.

---

**Measurements: Coordinate System**

Figure 134

From the **Coordinate System** drop-down list, you can select the coordinate system to be used while using the **Measure Distances**, **Measure Angles** functions (see page 293) or **Measure Values/Hounsfield Unit** functions (see page 291).

*NOTE: The display of the selected coordinate system is described on page 292. Coordinate system options are described on the following page.*

---

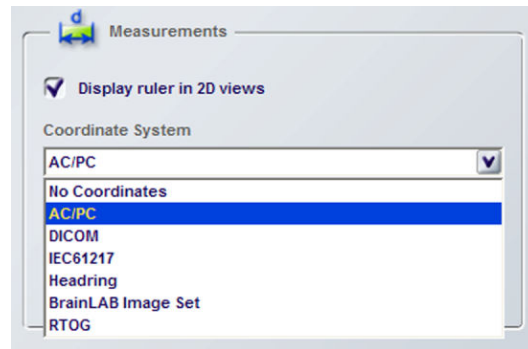
**Coordinate System Options**

Option	Explanation
No Coordinates	No coordinates are displayed
AC/PC	Coordinate system is aligned with the AC/PC system as defined in AC/PC localization (see page 133)
DICOM	Coordinate system according to DICOM standard
IEC61217	Coordinate system according to IEC61217
Headring	Coordinate system according to the headring/localizer combination
Brainlab Image Set	Brainlab internal coordinate system
RTOG	Coordinate system according to RTOG

## 18.3.2 3D Thresholding

### General Information

In this tab, you can define the threshold for the range of gray values that are used for the calculation of the 3D model of the selected image set.

Depending on the image set, values are displayed as follows:

- CT: Hounsfield units (HU)
- MR and SPECT: Gray values
- PET: Standardized uptake values (SUV)

*NOTE: More information on these values is provided on page 291.*

### How to Define the Threshold

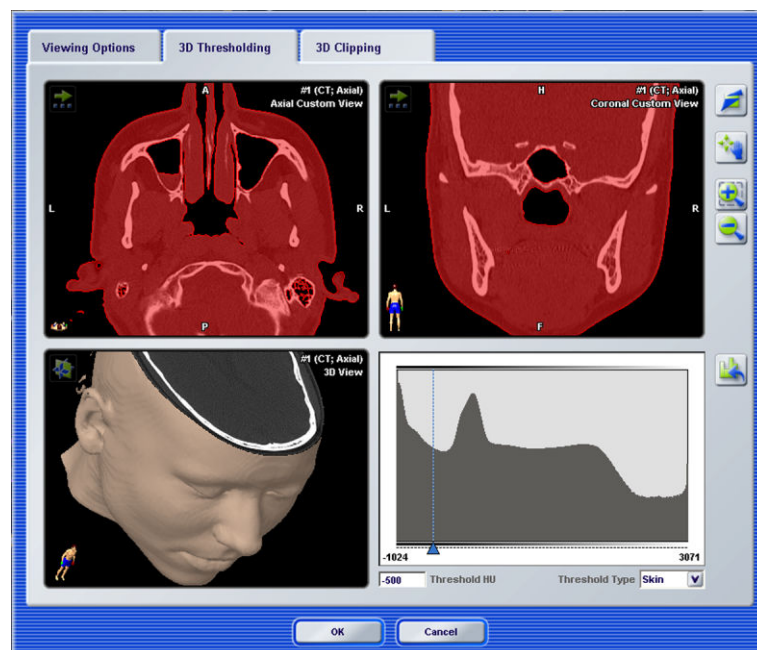



Figure 135

Steps	
	Use the following options to adjust the threshold: <ul style="list-style-type: none"> <li>• Use the slider bar in the mapping function (bottom right of the screen)</li> </ul>
1.	<ul style="list-style-type: none"> <li>• Enter the value in the <b>Threshold</b> field beneath the mapping function</li> <li>• Select the predefined threshold type from the drop-down list (<b>Skin</b> or <b>Bone</b>, for CT image sets only)</li> </ul>
2.	To create a preview of the resulting 3D model, click the update view at the bottom left of the screen.

### How to Reset the Threshold

Step	
	To reset the threshold to the default skin/bone value, click the <b>Reset Threshold</b> button in the <b>3D Thresholding</b> dialog.



### 18.3.3 3D Clipping

#### General Information

In this tab, you can define the part of the image to be displayed in the image views by:

- Positioning a frame around a part of the image you would like excluded from the 3D view (**Enable Clipping Range**)
- Excluding a quadrant of the 3D model in order to display a cross-section of the image set (**Enable Cubic Cut**)

#### How to Define a Clipping Range

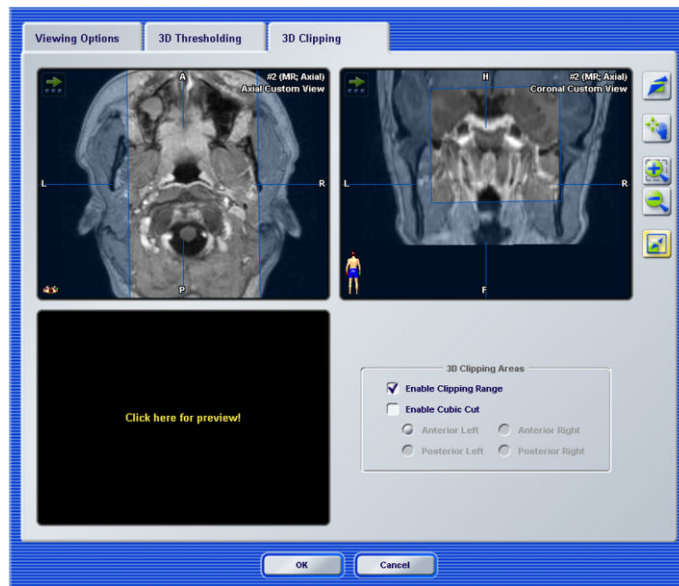



Figure 136

Steps	
1.	Click <b>Enable Clipping Range</b> . A blue frame is displayed in the upper image views.
2.	 If not already enabled, click the <b>Adjust Clipping Range/Cubic Cut</b> button in the toolbar.
3.	Position the mouse pointer over the frame and adjust it so that it surrounds the area to be excluded from the 3D view.
4.	To create a preview of the resulting 3D model, click the update view at the bottom left of the screen.

**How to Define a Cubic Cut**

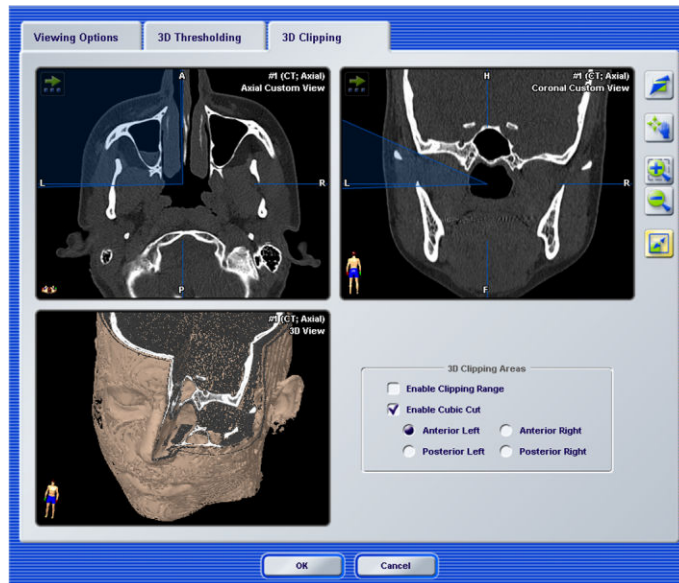



Figure 137

Steps	
1.	Click <b>Enable Cubic Cut</b> . A blue frame is displayed in the upper image views.
2.	 If not already enabled, click <b>Adjust Clipping Range/Cubic Cut</b> in the toolbar.
3.	Select a quadrant to be excluded from the 3D view: <ul style="list-style-type: none"> <li>• <b>Anterior Left</b></li> <li>• <b>Anterior Right</b></li> <li>• <b>Posterior Left</b></li> <li>• <b>Posterior Right</b></li> </ul>
4.	Click on either edge of the quadrant and adjust the angles to define the area to be excluded from the 3D display.
5.	To create a preview of the resulting 3D model, click the update view at the bottom left of the screen.

## 18.4 Viewing Images

### Browsing and Scrolling Images

---



#### General Information

The browsing and scrolling direction corresponds to the selected display orientation (see page 276) and is represented by the patient icon in the lower left corner of the view.

---

#### How to Browse Slices

The **Browse Slice** and **Browse Slices** buttons are available in views that display original image slices or slice reconstructions (see page 67).

Options	
	Click <b>Browse Slice</b> to advance forward or backward by one slice.
	Click <b>Browse Slices</b> to advance forward or backward by 3 or 7 slices (e.g., in the <b>4 Views</b> or <b>8 Views</b> tabs).

---

#### How Scroll Through Images

The scrolling function varies depending on the selected tab:

- **Depth Scrolling:** In reconstruction views, use this button to scroll through scan reconstructions
- **Slice Scrolling:** In slice views, use this button to scroll through available slices (similar to the slice browsing function)

Steps	
1.	 Click the scrolling button to activate it.
2.	Hold down the left mouse button and move the mouse pointer upwards or downwards on the selected image to display the required depth or slice.
3.	Click the button again to disable the function.

*NOTE: The original slice distance is different than the slice distance used for reconstructions.*

## 18.4.1 Pan and Recenter

### General Information

The **Pan and Recenter** function allows you to:

- View specific planes in the image set
- Drag the image in order to better examine a particular area

### How to Use Pan and Recenter

Steps	
1.	 Click <b>Pan and Recenter</b> to display vertical and horizontal planes indicated by blue lines on the images.
2.	<ul style="list-style-type: none"> <li>• To view a specific plane, click the mouse pointer on a line (representing a plane) and drag it to the desired area.</li> <li>• To simultaneously move planes, click on the intersection point of both lines and drag the lines to the desired position.</li> </ul> <p>The view is recentered to the new position.</p>
3.	<p>To examine a particular area in the image, place the mouse pointer on the image (mouse pointer is displayed as hand symbol) and drag it to the required position.</p> <p>You can also use the <b>Zoom In</b> function (see page 285) in combination with the panning feature to better examine the image.</p>
4.	Click the button again to disable the function.

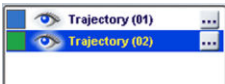

### Additional Methods for Centering Views

Options	
	<p>Clicking on the find icon centers the view to the point that is selected in the functions area.</p> <p><i>NOTE: The find icon is available during registration points and trajectory planning.</i></p>
	<p>Double-click directly on the item shown in the list in the functions area to center the view accordingly. In trajectory planning, for example, you can center the view to either the target or entry point.</p>

## 18.4.2 Zooming Images

---

### How to Zoom

Button	Explanation
	Clicking <b>Zoom In</b> zooms in on the displayed image. To zoom in on a specific region of interest: <ul style="list-style-type: none"><li>• Position the mouse pointer on the area</li><li>• Hold down the left mouse button and drag to open a selection frame</li><li>• Release the mouse pointer to show the zoomed in region of interest</li></ul>
	Clicking <b>Zoom Out</b> allows you to obtain an overview of the entire image.

*NOTE: Right clicking in the view in **Zoom In** mode will zoom out. Right clicking in **Zoom Out** mode will zoom in.*

# 18.5 Windowing



## Basic Windowing

### General Information

You can use windowing settings to adjust the gray level distribution in displayed images to improve the visibility or contrast of structures.

You can adjust windowing settings in axial, sagittal and coronal views.

### How to Adjust Windowing Settings

Steps	
1.	 <p>Click the <b>Windowing</b> button to enable it.</p>
2.	 <p>To view current settings, click on the view and hold down the left mouse button to display a mapping function.  <i>NOTE: The mapping function disappears as soon as the mouse button is released again.</i></p>
3.	Click the button again to disable the function.

## 18.5.1 Advanced Windowing

### General Information

The **Advanced Windowing** function provides advanced options for adjusting the gray value distribution so that it is easier to distinguish bone structure or marker points from soft tissue.

Depending on the image set, values are displayed as follows:

- CT: Hounsfield units (HU)
- MR and SPECT: Gray values
- PET: Standardized uptake values (SUV)

*NOTE: More information on these values is provided on page 291.*

### How to Activate Advanced Windowing

Step	
	Click <b>Advanced Windowing</b> to open the <b>Windowing</b> dialog.

### Screen Layout

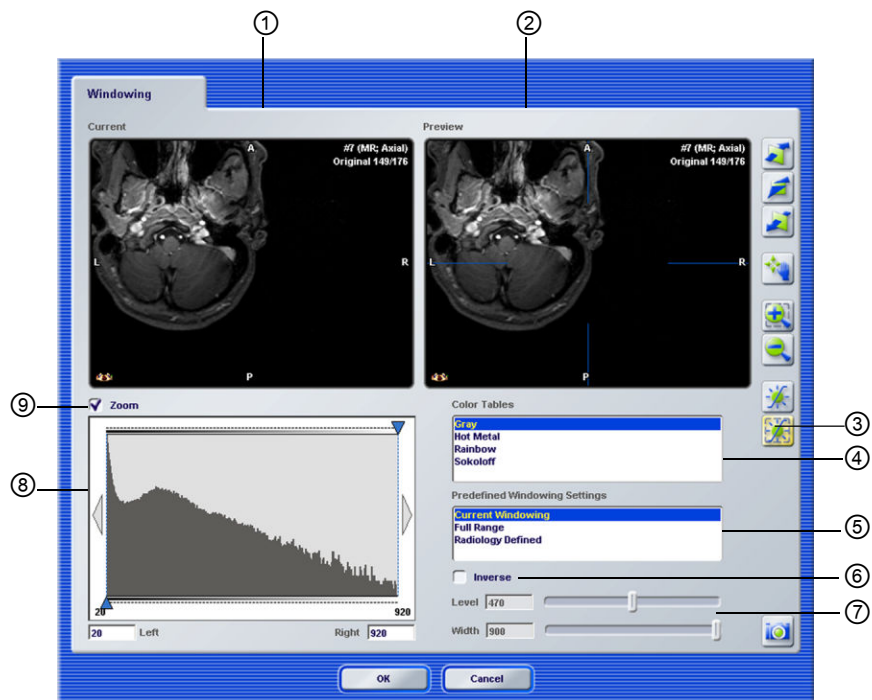

Figure 138



*NOTE: During image fusion (see page 147), two tab pages (**Windowing Amber** and **Windowing Blue**) are provided, allowing you to define individual windowing settings for each image set.*

### Screen Explanation

No.	Area	Explanation
①	Current image	Original slice from the current image set

No.	Area	Explanation
②	Preview	Preview of the modified slice according to your adjustments
③	Windowing Region of Interest function	Apply gray values taken from a specific region of the image set, to the entire image set
④	Color Tables	Color scheme options <ul style="list-style-type: none"> <li>• Gray</li> <li>• Hot Metal</li> <li>• Rainbow</li> <li>• Sokoloff</li> </ul>
⑤	Predefined Windowing Settings	Select predefined windowing values: <ul style="list-style-type: none"> <li>• Current Windowing: Reset windowing settings to those defined when you first entered this dialog</li> <li>• Radiology Defined: Apply settings defined when images were initially acquired</li> <li>• Bone: Apply settings to blend out soft tissue and display bone more clearly (CT image sets only)</li> <li>• Full Range: Apply the full range of gray values/Hounsfield units acquired by the scanner</li> </ul>
⑥	Inverse check box	Allows you to invert the color display, reversing the default setting so that air, for example, is displayed in white and bone in black. This is useful in order to improve contrast before performing object creation (see page 163).
⑦	Level & Width slider bars	Adjust the gray value level and width
⑧	Mapping function	Provides a graphical representation of the Hounsfield unit/gray value distribution in the image data
⑨	Zoom check box	Limits the graphical representation of the Hounsfield unit/gray value distribution to a specific area

### How to Adjust the Gray Level and Width

Options
<p>To adjust the image windowing center:</p>  <ul style="list-style-type: none"> <li>• Enter the value in the <b>Level</b> field, or</li> <li>• Adjust the slider until the required value is shown</li> </ul>
<p>To adjust the image windowing width:</p>  <ul style="list-style-type: none"> <li>• Enter the value in the <b>Width</b> field, or</li> <li>• Adjust the slider until the required value is shown</li> </ul>



### How to Adjust the Width of Gray Value Distribution

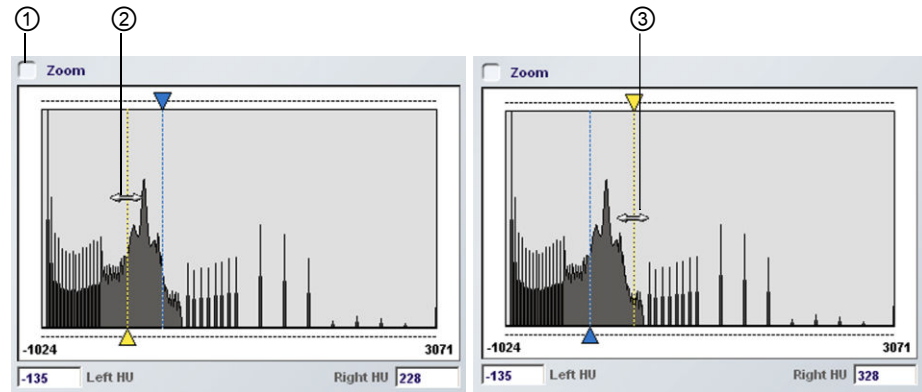

Figure 139

#### Options

To adjust the values:

- Enter the **Right** and **Left** values directly in the fields provided, or
- Use the mouse pointer to adjust the left value ② and/or right value ③ sliders until the required values are shown in the corresponding fields

To restrict the graphical representation of the gray value distribution to a specific area so that windowing can be more accurately defined, activate the **Zoom** ① check box.

### How to Use Windowing in the Region of Interest

This option allows you to define a specific area in the image set and then apply gray values from this area to the complete data set.

#### Steps

1.  Click the **Windowing Region of Interest** button to enable it.

- 2.

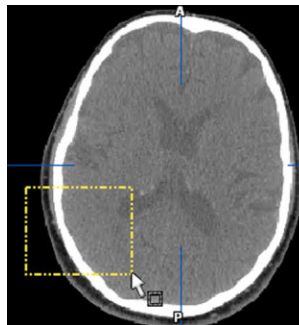

In the **Preview** window, use the mouse pointer to draw a frame around the area from which you would like to select the windowing settings.

*NOTE: You can also click in the **Preview** area on the required location in the image.*

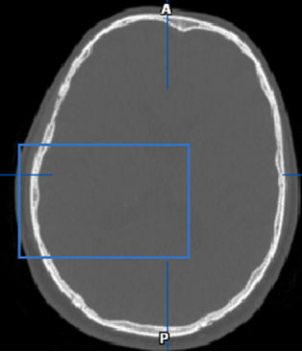

Steps	
3.	 <p>Release the left mouse button to see the calculated preview results. The software takes the minimum and maximum values from the defined area and applies them to the <b>Level</b> and <b>Width</b> sliders, and <b>Left</b> and <b>Right</b> fields.</p>
4.	Click <b>OK</b> to apply the gray values from the selected area to the entire image.

## 18.6 Measurement Functions

### Hounsfield Units/Gray Values Measurement

#### General Information

The **Measure Hounsfield Units** and **Measure Values** functions allow you to measure either Hounsfield units or gray values of up to three points in an image slice.

Button	Explanation
	<b>Measure Hounsfield Units</b> is displayed for CT image sets
	<b>Measure Values</b> is displayed for other image sets (e.g., MR, SPECT, PET)

#### Measurement Units

Unit	Explanation
HU (Hounsfield units)	With diagnostic CT imaging, density information is evaluated in international Hounsfield Units (HU) on a scale ranging from: -1024 to 3071, where 0 is the value for water (1.0g/cm <sup>3</sup> ) and -1000 the value for air. With neurological CT imaging, a level of 40 HU and a width of 100 HU is usually used to contrast brain tissue.
Gray values	The gray value display ranges from: <ul style="list-style-type: none"> <li>• 0 (black) to 255 (white) for 8-bit images</li> <li>• 0 (black) to 65535 (white) for 16-bit images</li> </ul>
FA values	Refers to the measure of fractional anisotropy and has a range of 0 - 1
ADC measurement (Apparent Diffusion Coefficient)	Expressed in mm <sup>2</sup> /sec
SUV (Standard uptake values)	Semi-quantitative way to assess PET activity at a given focus The implementation of the calculation of standard uptake values in PET scans into the <b>iPlan</b> software is based on the following publication: "M.Schmidt et al., 18F-FDG PET for detecting recurrent head and neck cancer, local lymph node involvement and distant metastases - Comparison of qualitative visual and semi quantitative analysis, Nuklearmedizin 3/2004; 91-101."

#### How to Measure Gray Values/Hounsfield Units

Steps
1. Click the measurement button ( <b>Measure Hounsfield Units</b> or <b>Measure Values</b> ).
2. Click the mouse pointer onto any point in the slice to display the relevant value at the selected point. To update the value dynamically, hold down the left mouse button and move the mouse pointer across the image.
3. Click the button again to disable it and remove the displayed value from the image view.

### Displayed Values

iPlan can only display the gray value/Hounsfield unit/SUV information per pixel as calculated and exported by the scanner. Please pay particular attention when interpreting this information, and make sure the information is correct. Cone beam CT data or rotational angio data, for example, will not contain actual HU values.



The user is responsible for ensuring the accuracy of the Hounsfield unit value shown.



As standard uptake values (SUV) can vary depending on the PET scanner used, always compare the displayed values with the SUV obtained directly at the scanner before use.

### Coordinate System Display

When you enable a measurement function in the toolbar, and then click in the image set, the software also displays image set coordinates at the selected point according to the coordinate system defined in the **Viewing Options** tab (see page 279).

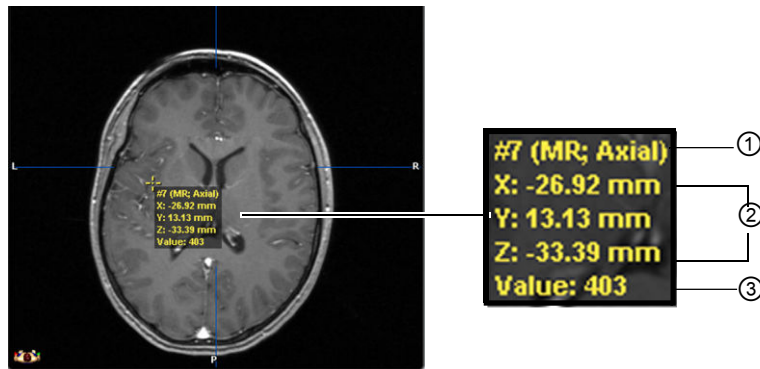

Figure 140

No.	Explanation
①	This line shows the reference on which the coordinate system is based. In this case, an axial MR image set labeled #7 ( <b>Brainlab Image Set</b> selected as the coordinate system in the <b>Viewing Options</b> tab). If you selected, e.g., <b>Headring</b> as the coordinate system in the <b>Viewing Options</b> tab, then this line would indicate the headring that is selected for the plan.
②	X, Y, Z coordinates for the selected point in the image set
③	Measurement value for the selected point.

*NOTE: The coordinates displayed here, in particular those for the headring, are not intended for arc adjustment. Only coordinates from the arc settings dialog or printout are to be used to perform the treatment. The coordinate system display is intended for viewing purposes only.*

## 18.6.1 Distance and Angle Measurement

---

### How to Measure Distances

The **Measure Distances** function allows you to measure the distance between up to three point pairs in the image.

Steps	
1.	 Click the <b>Measure Distances</b> button to enable it.
2.	Click the mouse pointer at two points in the data set. The software calculates and displays the distance in millimeters between the points. <i>NOTE: You can reposition points by clicking the mouse and dragging the selected point to a new location.</i>
3.	Click the button again to disable it and remove the displayed value from the image view.

### How to Measure Angles

The **Measure Angles** function allows you to measure the angle between any three points in the image.

Up to three groups of three points can be displayed simultaneously.

Steps	
1.	 Click the <b>Measure Angles</b> button to enable it.
2.	Click the mouse pointer at three points in the image. The software calculates and displays the angle between the selected points. <i>NOTE: You can reposition points by clicking the mouse and dragging the selected point to a new location.</i>
3.	Click the button again to disable it and remove the displayed value from the image view.

## 18.7 Labeled Points

### Adding and Removing Points

#### General Information

The **Add/Remove Points** button allows you to set landmarks in the image set. You can use this function to emphasize points of interest during intra-operative navigation using Brainlab navigation software.

#### How to Add Points

Steps	
1.	 Click the <b>Add/Remove Points</b> button.
2.	With the left mouse button, click directly in the image where the point is to be placed. The <b>Properties</b> dialog opens.
3.	From the <b>Image Set</b> field, select the image set in which to place the point.
4.	In the <b>Name</b> field, enter a name for the point. <i>NOTE: If you do not name the point, it is added to the list as <b>Labeled Point</b> and numbered sequentially.</i>
5.	From the color palette, select a color for the point.
6.	If you would like to define groups of labeled points that e.g., belong to a particular structure, click the <b>New Groups...</b> button and name the group accordingly.
7.	Click <b>OK</b> to confirm your settings and show the point in the image views.

**Displayed Points**

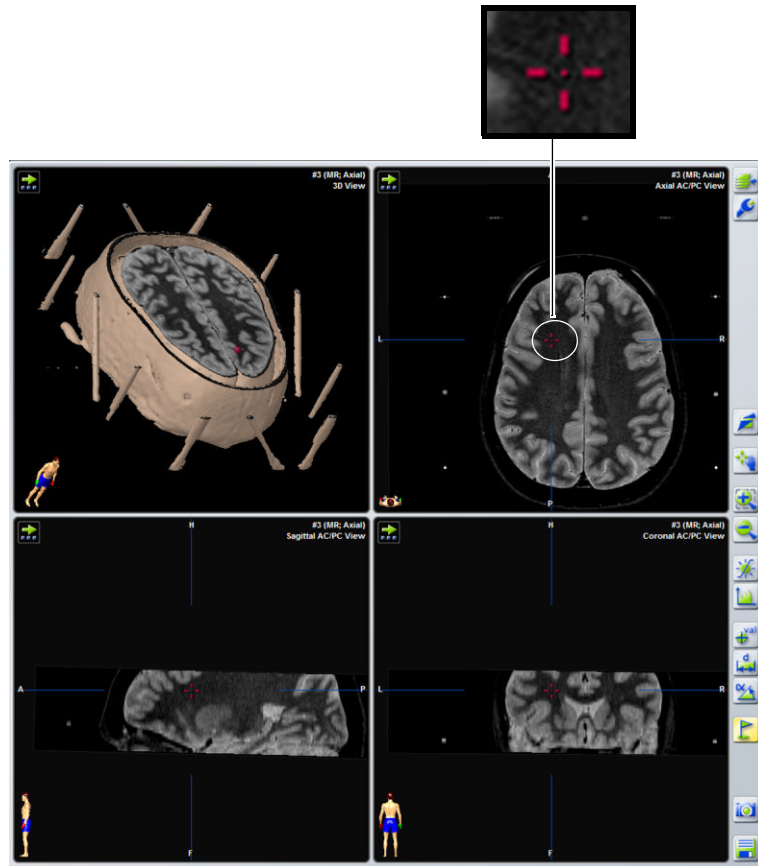



Figure 141

**Managing Points**

Once you have added points to the treatment plan, you can manage the points in the **Plan Content** tab (see page 91).

**How to Remove Points**

Steps	
1.	 Click the <b>Add/Remove Points</b> button.
2.	With the right mouse button, click directly on the point you would like to remove.

# 18.8 Screenshots

## Overview

### How to Take Screenshots

Step	
	Click <b>Screenshot</b> to take a screenshot of the current screen.

### Saved Screenshots

Placing the mouse pointer over the **Screenshot** button displays a tooltip message ① indicating the folder to which screenshots are saved (subfolder named Screenshots in the Brainlab folder, created by Brainlab support).

Generally the storage path is F:\Brainlab\Screenshots.

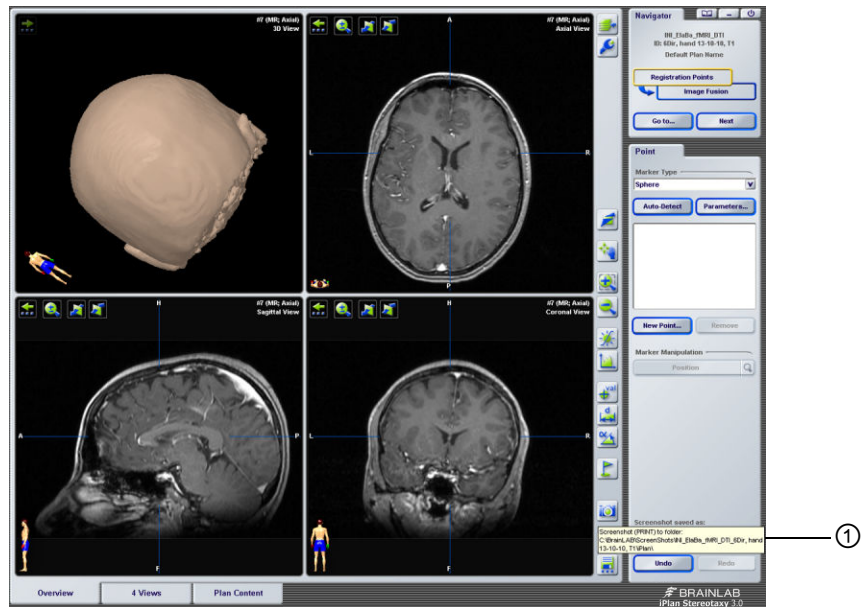

Figure 142

### Patient Confidentiality

The name of the patient is displayed on each screenshot. To maintain patient confidentiality, ensure that access to all screenshots is restricted to the relevant medical personnel.



# 19 SAVING PLANS

## 19.1 Saving a Treatment Plan

### Overview

---

#### General Information

You can use the **Save Treatment Plan** button in the toolbar to save the treatment plan in the advanced Brainlab data format in order to review the treatment plan later, or to create multiple stages of your plan.

You can save your treatment plan after any planning task.

Via the **Save and Export** planning task, you can also export the treatment plan to a data format different to the format that was loaded. Export options are described on page 303.



**If you open a treatment plan, or exit the software without saving changes in the current treatment plan, these changes are lost and cannot be recovered.**

---

#### Automatic Saving Procedure

**iPlan** may automatically save the current treatment plan and exit the application if the software is idle for a certain time period with no user interaction. In this case, the next time you open the software, you can select the plan (labeled **Automatically Saved**) in the **Plans** dialog (see page 37).

## 19.1.1 Saving Changes

### How to Save

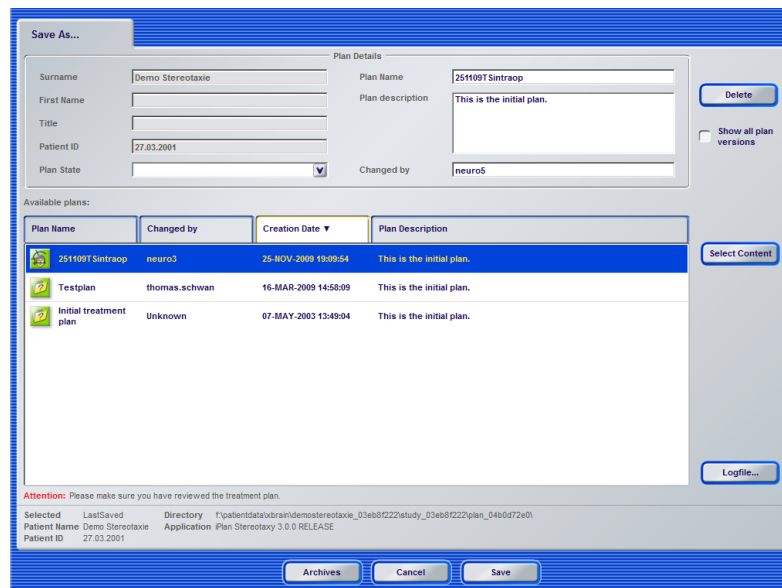



Figure 143

Steps	
1.	 Click the <b>Save Treatment Plan</b> button in the toolbar to open the <b>Save As...</b> dialog.
2.	From the <b>Plan State</b> drop down list, define the plan status ( <b>Planning in progress</b> , <b>Ready to review</b> , or <b>Planning finished</b> ). <i>NOTE: The status is shown the next time you open the treatment plan. If you would like additional plan status options, please contact Brainlab support.</i>
3.	Enter the name and description for the plan in the fields provided. Enter the name of the planner in the <b>Changed by</b> field.
4.	Click <b>Save</b> to close the dialog and return to the previous <b>iPlan</b> screen.

## Deselecting Image Data

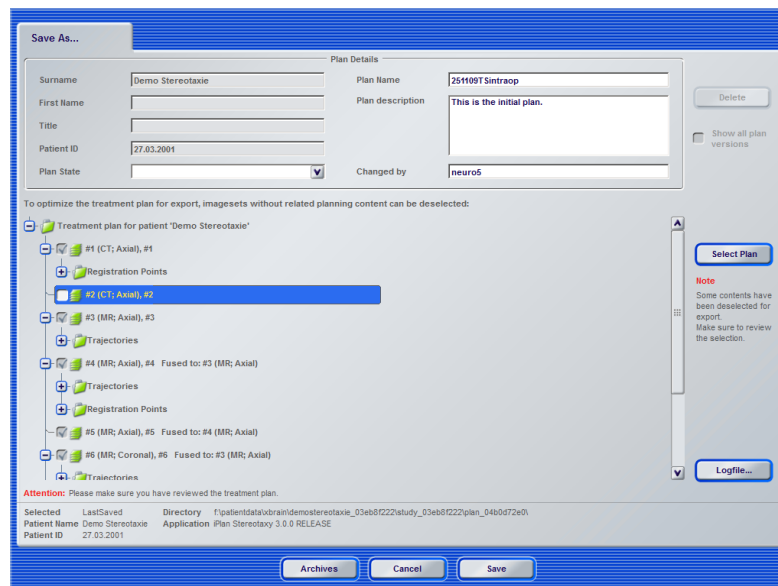

Figure 144

You can deselect slices to reduce the file size should you experience memory issues.

*NOTE: Only exclude slices that do not contain planning content.*

Steps
1. Choose <b>Select Content</b> from the <b>Save As...</b> dialog.
2. Deselect the image set as required.
3. Click <b>Save</b> to close the dialog and return to the previous <b>iPlan</b> screen.

## Additional Options

Options
To delete a treatment plan, select a plan from the list and click <b>Delete</b> .
Enable the <b>Show all plan versions</b> check box to show auto-saved or plans saved manually at different stages with the same name.
To display a log file containing supplementary information on the steps completed so far, click <b>Logfile...</b> (see page 22).
To export the treatment plan to another data format, click <b>Archives</b> (see page 24).

## 19.1.2 Changing Directory Settings

### How to Change Settings

Treatment plan data is saved to a preconfigured directory. If required, you can change various settings for the directory.

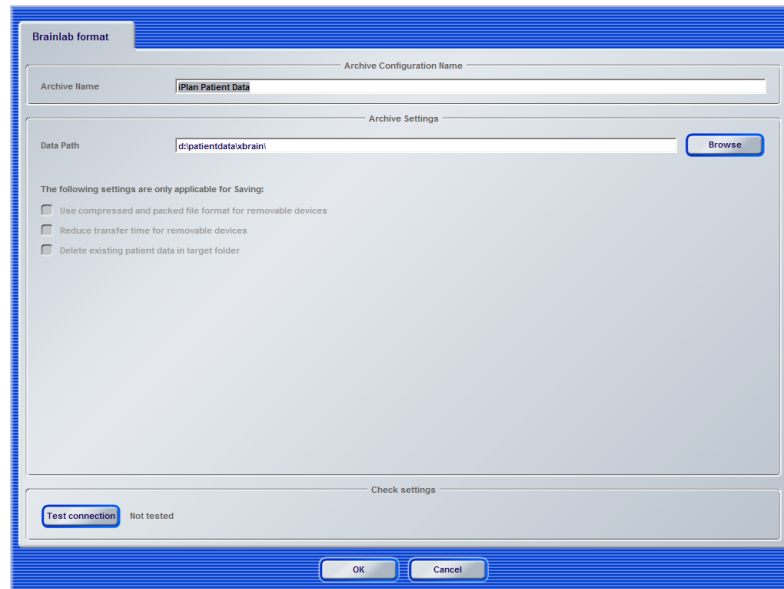

Figure 145

Steps	
1.	Click <b>Archives</b> to open the <b>Save Archives</b> dialog.
2.	Select the archive that you would like to change.
3.	Click <b>Settings</b> to open the <b>Brainlab format</b> dialog (shown above).
4.	<ul style="list-style-type: none"> <li>In the <b>Data path</b> field, click <b>Browse</b> to navigate to the relevant network or local path.</li> <li>Alternatively, enter the file path for the patient data manually.</li> </ul>
5.	Enable the relevant check boxes to apply applicable settings for saving: <ul style="list-style-type: none"> <li><b>Use compressed and packed file format for removable devices:</b> Speed up archiving on removable USB drives.</li> <li><b>Reduce transfer time for removable devices:</b> Speed up archiving on removable devices by omitting raw data that is not used by navigation.</li> <li><b>Delete existing patient data in target folder:</b> Cleans up the removable device.</li> </ul>
6.	To verify that the file path is valid, click <b>Test connection</b> .
7.	Click <b>OK</b> to confirm your settings and return to the <b>Save As...</b> dialog.



If iPlan is started via Content Manager, the data must be stored in the same archive it was loaded from. Otherwise, the planning results will not be available for further use with Brainlab Elements.

## 19.2 Saving a Plan for Use with iPlan RT Image

### Compatibility with iPlan RT Image Software

---

#### General Information

**iPlan 3.0** is compatible with **iPlan RT Image 4.1**. However, before loading a plan to **iPlan RT Image 4.1** that has been created in **iPlan 3.0**, consider the topics discussed in this section.

---

#### Localized Image Sets



If you load a localized image set containing intermediate ignored slices (slices that have been ignored within a sequence of localized slices, see page 110), to **iPlan RT Image 4.1**, you should de-localize the image set and localize it again in **iPlan RT Image**. Intermediate ignored slices are contra-indicated for radiotherapy planning.



When multiple localizations are loaded to **iPlan RT Image 4.1** via a treatment plan saved by **iPlan Stereotaxy 3.0**, the stereotactic reference cannot be defined by the user in **iPlan RT Image** as it was defined in **iPlan Stereotaxy**. To prevent patient injury (as a result of applying incorrect stereotactic coordinates in **iPlan RT Image**), do not load multiple localizations to **iPlan RT Image**. You can e.g., de-localize the irrelevant localizations before saving the plan in **iPlan Stereotaxy** or after loading to **iPlan RT Image**. You can then redo the localization **iPlan RT Image 4.1**.

---

#### Display of Coordinates



When using output from one **iPlan** application as input for another **iPlan** application, the heading/localizer coordinates may refer to different anatomical positions, depending on which image set is used as the stereotactic reference defining the heading/localizer coordinate system/origin. Make sure to verify the anatomical positions of transferred data.

---

#### Planned Objects



If the treatment plan contains planned objects, prepare the objects for export using the **Prepare for Export...** function, before saving the plan in **iPlan 3.0**. The conditions under which this function must be used are described on page 196. Otherwise, the treatment plan cannot be loaded to **iPlan RT Image 4.1**.



# 20 EXPORTING THE PLAN AND CLOSING iPLAN

## 20.1 Exporting: Standard Brainlab Format

### Exporting to Standard Brainlab Format

#### General Information

This option allows you to export the treatment plan for use with a Brainlab navigation software.

#### How to Access Export

Steps	
1.	Click <b>Go to...</b> in the <b>Navigator</b> area to open the <b>iPlan Navigator</b> .
2.	Click <b>Save and Export</b> to open the <b>Save Archives</b> dialog.
3.	Click <b>New Archives</b> to open the <b>New Archive</b> dialog.
4.	Select <b>Standard Brainlab</b> and click <b>Next</b> . The <b>Brainlab Standard</b> dialog opens where you can define the archive settings.

#### How to Define Archive Settings

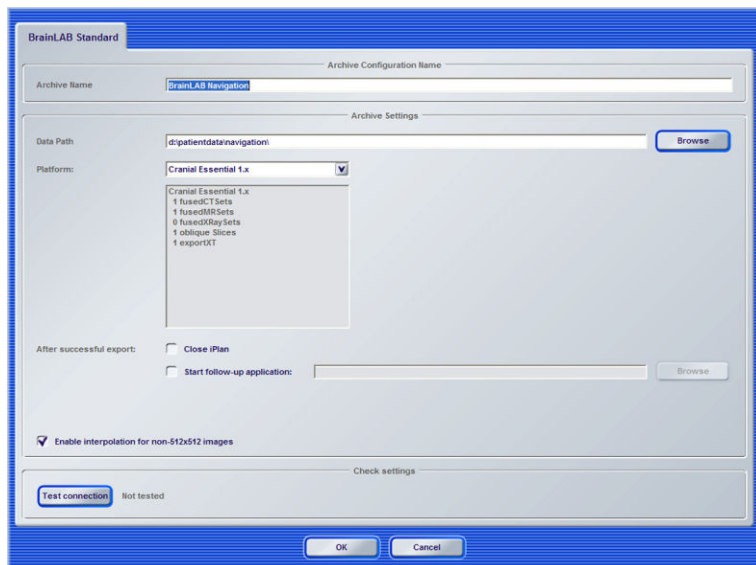

Figure 146

Steps	
1.	In the <b>Brainlab Standard</b> dialog, enter a name for the archive in the <b>Archive Name</b> field.
2.	To define a new directory to which to save data, click <b>Browse</b> to navigate to the relevant network or local path in the <b>Data Path</b> field. Alternatively, enter the file path manually.
3.	From the <b>Platform</b> drop down list, select the export platform (e.g, <b>Cranial Essential 1.x</b> ). <i>NOTE: In order to successfully load a treatment plan to the navigation system, make sure to select the correct export platform and export location.</i>
4.	<b>In After successful export:</b> <ul style="list-style-type: none"> <li>• Enable the <b>Close iPlan</b> check box to close <b>iPlan</b> following export.</li> <li>• Enable the <b>Start follow-up application</b> check box and click <b>Browse</b> to select a follow up application.</li> </ul>
5.	If required, click <b>Enable interpolation for non-512x512 images</b> .
6.	To verify that the file path is valid, click <b>Test connection</b> .
7.	Click <b>OK</b> to save your settings and return to the <b>Save Archives</b> dialog where the new archive is now shown in the list.

### Save Archives Dialog

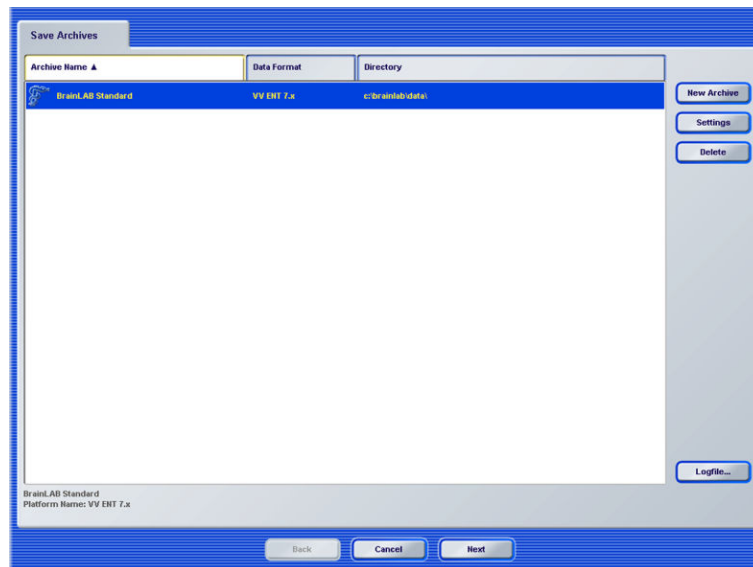

Figure 147

Options
To continue the export procedure, select the archive from the list and click <b>Next</b> to open the <b>Export</b> dialog (see page 305).
To define a different directory to which the plan should be exported, click <b>Settings</b> . Adjust the path in the <b>Data path</b> field as described on page 303.
To delete an archive, select an archive from the list and click <b>Delete</b> .
To display a log file containing supplementary information on the steps completed so far, click <b>Logfile</b> (see page 22).



**How to Export the Plan**

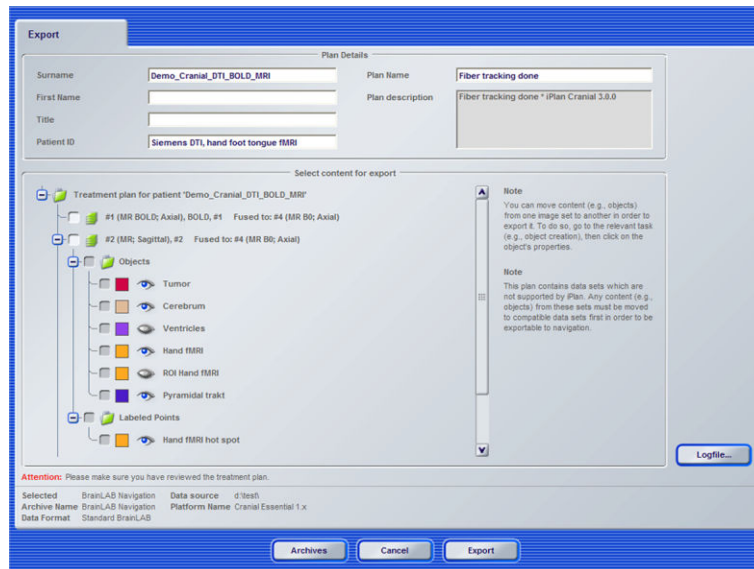

Figure 148

Steps	
1.	In the <b>Save Archives</b> dialog, select the archive and click <b>Next</b> to open the <b>Export</b> dialog (shown above).
2.	In the <b>Plan Details</b> section of the dialog, enter the name and description for the plan in the fields provided.
3.	In the <b>Select content for export</b> section of the dialog, enable the corresponding check boxes to select the image sets and content that you would like to export. <i>NOTE: Prior to exporting objects created in <b>Object Creation</b>, you can prepare them for export by selecting a different image set in which to export the object (see page 196).</i>
4.	Click <b>Export</b> to export your treatment plan.

**Important Tips for Data Export**

- To successfully export the plan, you must select the necessary planned content for the selected data set. If the check box of planned content is disabled (eye icon closed, see page 62), you must enable it if you wish to export the content.
- Depending on available processor memory, the planned objects may be temporarily invisible during export, but will nevertheless be available in navigation.
- Complex objects containing a very large number of fragments cannot always be exported for navigation. You can use the **Maximal Fragment Number** feature to simplify such objects (see page 177).
- Treatment plans containing localized image sets with image slices that have been ignored (see page 110) will be exported to the Brainlab navigation software without the ignored slices. Ignored image slices are not supported by the standard Brainlab format.



**Data sets exceeding the slice set coordinate of +/-511 mm will be loaded by iPlan for planning purposes, but will be disabled for export (including connected plan content) as this data is not supported by the Brainlab navigation software.**

### Treatment Plan Information

Due to data format limitations, the following treatment plan details are limited to a maximum number of characters for export:

- Patient name: Maximum 33 characters
- Patient ID: Maximum 17 characters
- 3D Object names: Maximum 23 characters
- Plan description: Maximum 110 characters



**If the maximum number of characters is exceeded, the information in the relevant field will be automatically shortened at export.**

## 20.1.1 Additional Export Information

---

### Display of Exported Objects

If the content (e.g., trajectories, created objects, etc.) was planned using more than eight colors, the number of colors will be reduced to the default setting (eight) when you export data for use with the navigation software. Make sure that you have selected colors that allow planned content to be easily distinguished from each other.

When exporting labeled points (see page 294), the points will be changed to a single color in the navigation software, regardless of the color planned in **iPlan**. When exporting multiple labeled points, these points will be combined into a single group in the navigation software.

---

### Treatment Plan Data



**Wait until the export procedure has been completed before loading the treatment plan onto the navigation system. Otherwise incomplete or incorrect data could be loaded, leading to incorrect patient treatment.**



**The appearance and visualization could differ between Brainlab applications (e.g. planning and navigation software) due to different user interfaces and workflows. Exported data should always be verified on the target platform prior to a surgery.**



**Multiple data sets that are fused by separate localization cannot be exported to a Kolibri or VectorVision navigation software. Only one reference data set can be localized while all other data sets must be fused by either manual, paired point or automatic image fusion methods if they are to be exported to a navigation application.**



**Before you select an export archive to an external media such as a Zip disk or USB flash drive, the media must first be plugged in. Otherwise, the plan content will be disabled for export.**

---

### Windowing in Exported Data Sets

If you performed windowing in a 16 bit non- CT data set in **iPlan**, the range of available gray values is limited by the navigation application (software versions < **7.x VectorVision cranial/ENT** and < **2.x Kolibri cranial/ENT**) when you export the data set. Only gray values between the left and right borders as defined in **Advanced Windowing** will be considered in the navigation application.



**Following export, the surgeon does not have the possibility to view and adjust the full range of gray values during navigation.**

The following image provides an example of the defined left and right gray values in **Advanced Windowing** in **iPlan** and illustrates how the windowing range is affected:

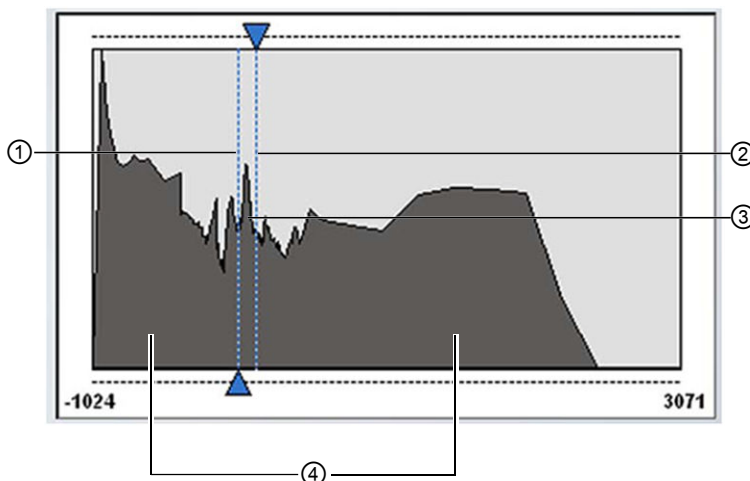

Figure 149

No.	Explanation
①	Defined left border of gray value
②	Defined right border of gray value
③	During export, the software converts the region between the left and right borders from 16 bit to 8 bit data. (65,536 gray values are reassigned to 256 gray values provided by 8 bit data.)
④	All of the area outside of the left and right borders is lost tissue differentiation (anatomical information) following export

*NOTE: You can adjust the windowing at any time prior to export by clicking the **Advanced Windowing** button in the toolbar (see page 152).*

### Unsuccessful Export

If you attempt to export a treatment plan producing a large number of data files (about 507 files or folders) in the root directory of your export zip disk, the export will stop and error messages are displayed.

In such cases, we recommend that you reformat (or clean up) the media and then attempt to export again as suggested in the dialog which appears. Alternatively, contact Brainlab support for more information.

### Media Formatting Guidelines

The following data storage restrictions must be considered when re-formatting the media:

Media Format	Data Storage Restrictions
FAT	A maximum number of 506 files or folders can be stored in a clean root directory of the media. If you attempt to store more than this, a system message appears.
FAT32	A large number of files or folders are supported. FAT32 format is not supported by Windows NT.
NTFS	A large number of files or folders are supported. Removable storage devices like Zip disk or USB flash drives can usually not be NTFS formatted in Windows XP. Auto-eject of media (e.g., Zip disk) will not work properly.

*NOTE: Make sure to clean up the root directory of your export media.*

## 20.2 Exporting: DICOM PACS

### Exporting to DICOM PACS

#### General Information

This option allows you to export screenshots in DICOM format to a PACS.

#### How to Access Export

Steps	
1.	Click <b>Go to...</b> in the <b>Navigator</b> area to open the <b>iPlan Navigator</b> .
2.	Click <b>Save and Export</b> to open the <b>Save Archives</b> dialog.
3.	Click <b>New Archives</b> to open the <b>New Archive</b> dialog.
4.	Select <b>DICOM export via Network</b> and click <b>Next</b> . The <b>DICOM PACS Export</b> dialog opens where you can define the archive settings.

#### How to Define Archive Settings

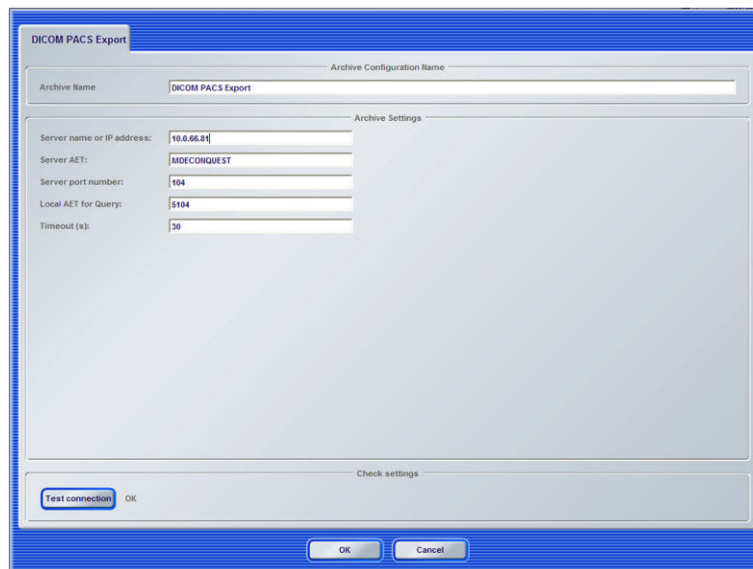

Figure 150

Steps	
1.	In the <b>DICOM PACS Export</b> dialog, enter a name for the archive in the <b>Archive Name</b> field.
2.	In the <b>Archive Settings</b> section, the communication settings are shown. <i>NOTE: These settings are usually configured by Brainlab support.</i>
3.	To verify that the specified local and server settings are valid, click <b>Test connection</b> .
4.	Click <b>OK</b> to save your settings and return to the <b>Save Archives</b> dialog where the new archive is now shown in the list.

## How to Export

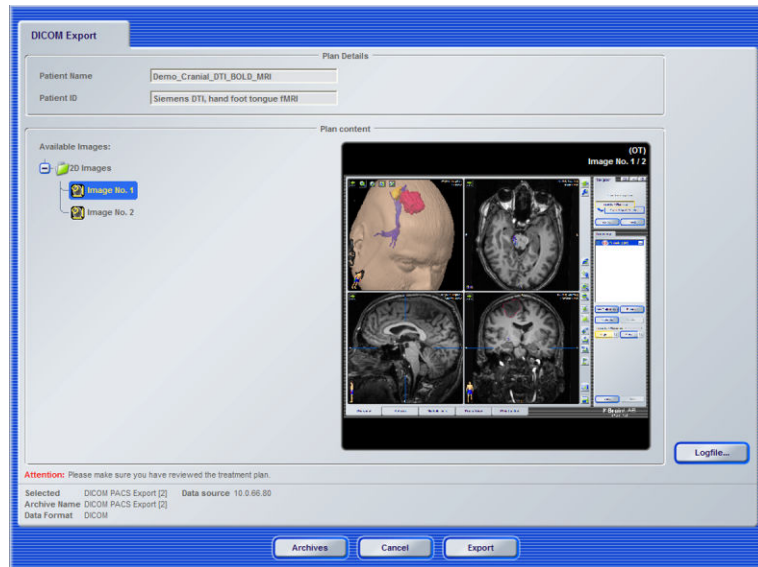

Figure 151

### Steps

1. In the **Save Archives** dialog, select the archive from the list and click **Next** to open the **DICOM Export** dialog (see above).
2. The images available for export are shown in the dialog. Click **Export** to export the images.

## 20.3 Closing the Software

### Overview

#### General Information

You can close the software at any time either via the shutdown icon or via the **iPlan Navigator**.

#### How to Exit using the Shutdown Icon

Step	
	Click the shutdown icon shown above the <b>Navigator</b> area.

#### How to Exit via the iPlan Navigator

Steps	
1.	Click <b>Go to...</b> in the <b>Navigator</b> section to open the <b>iPlan Navigator</b> .
2.	Click <b>Exit</b> and click <b>OK</b> .

#### Unsaved Changes

If there are unsaved changes in the treatment plan, the following dialog is displayed:

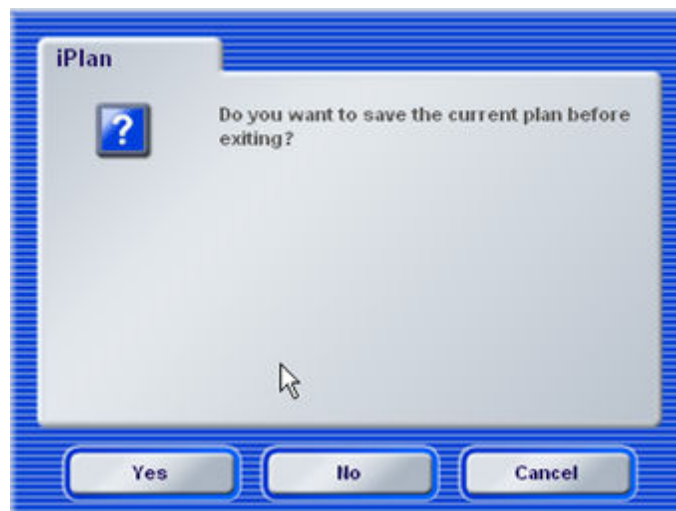

Figure 152

Options	
	To save changes, click <b>Yes</b> .
	To shut down the software without saving changes, click <b>No</b> .





# 21 iHELP (REMOTE CUSTOMER SUPPORT)

## 21.1 Introduction

### Using iHelp

---

#### General Information

If requested, the **iPlan** workstation can be equipped with remote access to Brainlab support. You can activate this remote access by clicking **Start iHelp** in the Windows **start** menu.

*NOTE: Contact Brainlab support before activating **iHelp**, as their activation is required before you can use the feature.*

---

#### Start Menu

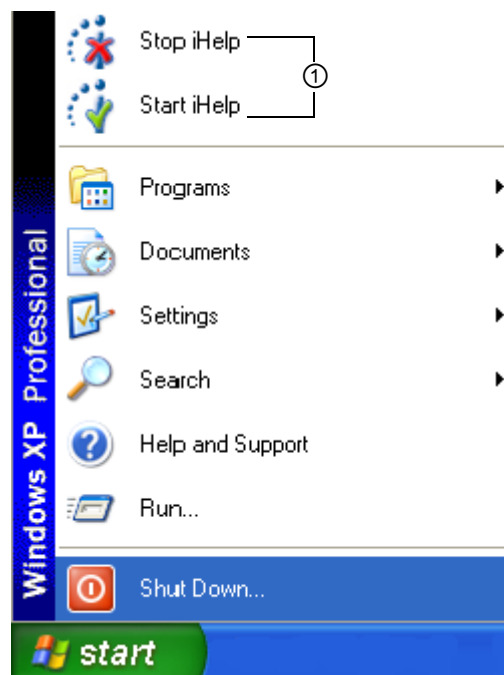

Figure 153

Once **iHelp** has been activated, corresponding icons are shown in the Windows **start** menu ①.

It is now possible for Brainlab support to remotely access your **iPlan** workstation, e.g., to perform diagnostics.

*NOTE: To deactivate remote access, click **Stop iHelp** in the Windows **start** menu.*

---

## How iHelp Works

The **iHelp** software, installed on the customer system (client), pings to the **iHelp** server on port 443 or 17002. Both are outbound connections whereby port 17002 is faster. With each ping the client tries to establish an SSL tunnel.

- To access the client, Brainlab support first connects to the **iHelp** server using an SSL tunnel.
- The **iHelp** server merges the two tunnels and Brainlab support can access the client.

---

## Installation Requirements

You do not need to make any changes to your firewall settings (unless you would like to provide Brainlab support with a faster connection to your client).

Provided your firewall already allows Internet connections to be made from inside your network, **iHelp** will be able to deliver remote assistance. You must start **iHelp** on the client, otherwise Brainlab support will not have access.

No patient data is transferred.

---

## For Further Information

Contact [iHelp.support@brainlab.com](mailto:iHelp.support@brainlab.com)

# INDEX

## Numerics

3D BOLD Objects.....	212
3D Clipping.....	281
3D Fiber Tracking objects.....	226
3D object display.....	277
3D Thresholding tab.....	280
3D views	
bone surface display.....	83
defining the display.....	281
objects.....	78
planes.....	78
thresholding.....	280
view type.....	77
4 Views.....	84
8 Views.....	85
9 Views.....	85

## A

AC Point.....	237
AC/PC coordinates.....	236
AC/PC Localization.....	133
modifying the AC/PC system.....	136
setting the AC/PC system.....	135
ADC measurement values.....	291
ADC trace map.....	18
Add/Remove Points.....	69,294
adding patient data.....	48
Administration	
patient data.....	35
Advanced Brainlab archive.....	26
Advanced Windowing.....	287
image fusion.....	152
region of interest.....	289
angles	
measurement.....	68
anterior commissure.....	133
arc mounting options	
Brainlab Stereotactic System.....	122
Elekta Leksell Micro-Stereotactic System.....	125
Leksell Multi Purpose Stereotactic Arc.....	125
Leksell Standard Stereotactic Arc.....	124
Radionics CRW ASL Arc System.....	126
arc ranges	
Brainlab Stereotactic System.....	121
Fischer Leibinger ZD Arc System.....	128
arc settings	
angles.....	235
modifying.....	234
target coordinates.....	235
arc system	
microdrive orientation.....	255
modifying mounting orientation.....	235
arc systems.....	121
Brainlab.....	121
Fischer Leibinger.....	128
Leksell.....	123
Radionics.....	126
archive	
Advanced Brainlab.....	26
creation.....	24

DICOM.....	27
DICOM PACS.....	29
MR Analyze.....	30
selection.....	32
settings.....	25
type.....	25
atlas based auto segmentation.....	174
Atlas Planning.....	238
Auto Fusion.....	155
automatic image fusion.....	155
automatic segmentation	
Anatomical Atlas.....	174
Band Thresholding.....	177

## B

B0 image.....	18
Band Thresholding.....	177
mask object.....	179
BOLD MRI data	
analyzing.....	205
image distortion.....	199
preprocessing.....	42
threshold.....	205
BOLD MRI image processing.....	199
BOLD MRI Mapping.....	197
3D BOLD objects.....	212
activation maps.....	197
defining region of interest.....	212
defining the design matrix.....	203
General Linear Model.....	197
interpolation settings.....	208
motion correction.....	211
motion correction parameters.....	199
Performing BOLD Analysis.....	205
reproducible brain activity.....	199
selecting a study.....	202
signal display.....	209
statistical parametric mapping.....	197
Task Paradigm.....	203
Threshold.....	205
Time Series View.....	207
valid data sets.....	198
bone surface display.....	83
Brainlab Standard	
defining archive settings.....	304
Brainlab support.....	9
Browse Slice.....	67,74,283
Browse Slices.....	67,283

## C

centering views.....	284
closing the software.....	311
compatibility	
cranial/ENT essential & unlimited.....	14
iPlan versions.....	14
Kolibri cranial.....	14
VectorVision cranial.....	14
compatible Brainlab medical instruments.....	13
compatible image types.....	56
Composing Options.....	68,74,79
Amber/Blue.....	80

Blending.....81  
 Overlay..... 80  
 Spyglass..... 79  
 verifying fusion.....161  
 configuring views..... 73  
 contact data.....9  
 coordinate system display.....292  
 coordinate systems.....279  
 Copy to Clipboard..... 91  
 custom views.....66

**D**

data storage restrictions.....308  
 Data Transfer  
 Overview.....19  
 Delete Slices  
 DICOM data.....40  
 deleting image slices.....45  
 Depth Scrolling.....67  
 DICOM archive.....27  
 DICOM BOLD data  
 importing.....41  
 DICOM data.....27  
 importing.....38  
 importing new.....48  
 DICOM images  
 sorting.....46  
 DICOM Info.....40,47  
 DICOM PACS  
 defining archive settings.....309  
 exporting screenshots.....309  
 import.....29  
 distances  
 measurement.....68  
 documentation.....17  
 donut markers  
 planning.....140  
 DTI data.....42  
 importing.....41  
 preprocessing.....42  
 selecting.....219

**E**

eddy currents.....42  
 Electrode Recording  
 adding and modifying tracks.....258  
 adjusting planned tracks.....261  
 amplitude settings.....263  
 CSV Export.....271  
 data backup.....271  
 entering comments.....265  
 entering negative side-effects.....266  
 entering positive effects.....266  
 example track coordinates.....256  
 MER/S data depth position.....268  
 MER/S Data tab.....264  
 parallel tracks.....253  
 planning relative to stereotactic arc.....254  
 templates.....269  
 Track Shift.....261  
 verifying tracks.....260  
 viewing MER/S data.....267  
 Enable Clipping Range.....281  
 Enable Cubic Cut.....281  
 export  
 DICOM PACS.....309  
 Standard Brainlab format.....303  
 eye symbol.....62

**F**

FA values.....291  
 feedback.....9  
 Fiber Tracking.....217  
 background information.....217  
 begin tracking fibers.....224  
 creating 3D fiber objects.....226  
 defining tracking parameters.....223  
 defining tracking region.....220  
 diffusion direction.....224  
 displayed fibers.....224  
 DTI Study Selection.....219  
 FA threshold.....223  
 minimum length of fibers.....223  
 selecting the DTI study.....219  
 windowing settings.....225  
 Fine views.....183  
 Fischer Leibinger ZD Arc System.....128  
 frame of reference image fusion.....156  
 Full Screen.....68,74  
 functions area.....62  
 fusing images.....147  
 fusion pairs for image fusion.....149

**G**

gray values  
 measurement.....68  
 guides.....17

**H**

harddisk  
 MR Analyze.....30  
 high resolution objects.....180  
 verifying.....183  
 Hounsfield Units.....291  
 measurement.....68

**I**

iHelp.....313  
 Image Fusion.....147  
 adjusting windowing.....152  
 Alternatives.....160  
 Automatic.....155  
 changing.....162  
 Coarse.....158  
 Fine.....159  
 Frame of Reference.....156  
 image contrast.....151  
 Modify ROI.....153,154  
 Registration Points.....160  
 spyglass.....161  
 verifying.....161  
 Volumetric.....157,161  
 windowing.....152  
 image interpolation.....276  
 image orientation.....43,66,276  
 image planes.....78  
 image set  
 modality.....44  
 submodality.....44,89  
 image sets  
 selection.....67  
 image views.....65  
 composing options.....79  
 view type.....77  
 images  
 configuring views.....73

# INDEX

deleting.....	45
import archive	
creating new.....	24
importing	
DICOM BOLD/DTI Data.....	41
DICOM data.....	38
iPlan Modules.....	55
iPlan Navigator.....	61
iPlan screen	
functions area.....	62
image views.....	65
tab pages.....	64

## L

landmarks	
planning.....	139
Leksell G-Frame Heading.....	123
Leksell Multi Purpose Stereotactic Arc.....	123
Leksell Standard Stereotactic Arc.....	123,124
loading a treatment plan.....	37
loading archives.....	32
loading patient data.....	33
Localization.....	103
3D view.....	108
adding markers.....	111
Assign Localizer.....	106
failed.....	104
functions.....	108
ignoring intermediate slices.....	110
ignoring slices.....	110
image slice color-coding.....	108
positioning markers.....	111
results.....	107
rod marker positions.....	108
selecting image set.....	106
selecting localizer and heading.....	106
supported images.....	103
Localization screen	
catalog view.....	108
magnified view.....	108
main view.....	108
Localizers	
Brainlab.....	114
Fischer.....	118
Leksell.....	115
Radionics.....	116
logfiles.....	22

## M

main screen.....	58
Manipulation	
DICOM data.....	39
manual image fusion.....	158
manuals.....	17
manufacturer.....	9
MC Point.....	237
Measure Angles.....	293
Measure Distances.....	293
Measure Hounsfield Units.....	291
Measure Values.....	291
ADC measurement.....	291
FA values.....	291
gray values.....	291
SUV.....	291
media format	
FAT.....	308
FAT32.....	308
NTFS.....	308
MER/S data	
arc mounting.....	254
coordinate references.....	256

entering MER/S data.....	263
merge data.....	48
microdrive adjustment capabilities.....	255
mid-sagittal plane.....	133
modifying fusion region.....	153
motion correction.....	42
MR Analyze.....	30
format.....	44
orientation.....	44
multiple image sets.....	87

## N

Navigator area.....	60
---------------------	----

## O

object contours.....	277
Object Creation.....	163
adding objects.....	165
Advanced Manipulation.....	185
automatic segmentation with atlas.....	174
Brush.....	168
correcting objects.....	184
Create Wall.....	187
enlarge object.....	186
Eraser.....	195
filling objects.....	194
high resolution objects.....	180
image interpolation.....	168
Logical Operations.....	188
Merging Objects.....	188
Multiple Objects.....	167
object contours.....	194
object properties.....	192
object volume.....	193
Original Slice Orientation.....	181
Patient Orientation.....	181
Preparing Objects for Export.....	196
Removing Objects.....	195
Scaling.....	186
SeedBrush.....	172
segmentation with Band Thresholding.....	177
Shrink Object.....	186
Single Object.....	165
small objects.....	170
SmartBrush.....	171
SmartShaper.....	184
Splitting objects.....	190
treatment template.....	167
verifying high resolution objects.....	183
vessel segmentation.....	178
object resolution	
object alignment.....	181
slice distance.....	181
Options	
3D Clipping tab.....	275
3D Thresholding tab.....	275
viewing.....	67
Viewing Options tab.....	275
orientation.....	43
original slice views.....	66

## P

Pan and Recenter.....	67,284
parallel tracks.....	253
reference.....	253
patient data	
adding.....	48
copying and moving.....	35
loading.....	33
PatXfer Software.....	14

PC Point..... 237  
 Plan Content tab.....88  
 plane views.....277  
 planned content  
     properties.....63  
     select color.....63  
     visibility.....62  
 planning task  
     AC/PC Localization.....133  
     BOLD MRI Mapping.....197  
     Fiber Tracking.....217  
     Image Fusion.....147  
     Localization.....103  
     Object Creation.....163  
     Registration Points.....137  
     selecting a planning task.....61  
     Stereotactic Planning.....229  
 posterior commissure.....133  
 Print.....69

**Q**

Quick Search.....21

**R**

Recenter View.....67,74  
 reconstruction views.....65  
 Registration Points.....137  
     add donut markers.....140  
     add landmarks.....139  
     Automatic Detection.....144  
     centering.....146  
     Parameters.....142  
     sphere markers.....142  
 registration points fusion.....160  
 ruler display.....278

**S**

Save and Export.....303  
 Save Treatment Plan.....69,297  
 scan direction.....44  
 scan protocols.....57  
 scanning instructions.....23  
 Schaltenbrand-Wahren atlas.....133,238,239  
 Screenshot.....69,296  
 scrolling through image slices.....283  
 SeedBrush.....172  
 setting landmarks.....294  
 shortcuts.....70  
 shutdown.....311  
 signal-to-noise ratio.....89  
 Slice Acquisition Order.....42  
 Slice and Image Set Selection.....67,74,135,258,274  
 Slice Scrolling.....67  
 slice views.....84  
 SmartBrush.....171  
 SmartShaper.....184  
 smoothing.....42  
 software user interface.....58  
 sorting  
     DICOM data.....40,46  
 sphere markers  
     defining parameters for detection.....142  
     detecting.....142  
     tolerance.....142  
 Standard Brainlab archive.....26  
 startup.....19  
 Stereotactic Localizers.....113  
 Stereotactic Planning.....229  
     AC/PC coordinates.....236  
     adding a trajectory.....231

Atlas planning.....238  
 creating parallel trajectories.....233  
 duplicating trajectories.....232  
 MER/S data.....244  
 modifying arc settings.....234  
 positioning a trajectory.....231  
 Print.....241  
 Probe View.....248  
     verifying trajectories.....245  
 Studies.....38  
 Study Selection.....37  
 support.....9

**T**

tab pages.....64  
 threshold  
     CT markers.....142  
     MR markers.....142  
 toolbar  
     3D Clipping.....281  
     3D Thresholding.....280  
     Add/Remove Points.....294  
     Browse Slice(s).....283  
     Browse Slices.....283  
     Depth Scrolling.....283  
     functions.....273  
     Gray Values.....291  
     Measure Angles.....293  
     Measure Distances.....293  
     Measure Hounsfield Units.....291  
     Measure Values.....291  
     Options.....275  
     Pan and Recenter.....284  
     screenshot.....296  
     Screenshot.....296  
     selecting images.....274  
     Slice and Image Set Selection.....274  
     Slice Scrolling.....283  
     The Windowing Dialog.....287  
     Viewing Options.....276  
     Windowing.....286  
     Windowing Region of Interest.....289  
     Zoom Images/Zoom In/Out Images.....285  
 track planning  
     angle definition.....254  
     coordinate references.....256  
 training.....17  
 trajectories  
     diameter.....277  
     display.....245  
 Trajectory Planning  
     Arc Settings.....234  
 treatment plan  
     compatibility with iPlan RT Image.....301  
     directory settings.....300  
     exporting.....303  
     loading.....37  
     saving.....297

**U**

Undo/Redo.....63  
 user guide  
     accessing.....60  
 user guides.....17

**V**

VectorVision cranial.....14  
 vessel segmentation.....178  
 View Options tab  
     Coordinate System.....279

## INDEX

Display Orientation.....	276
Display ruler in 2D views.....	278
Plane View Options.....	277
Show 3D objects in 2D views.....	277
Show only contours.....	277
Show Trajectory Diameter.....	277
Use image interpolation.....	276
View Orientation.....	68,73
view tabs	
Multiple Sets.....	87
Plan Content.....	88
slices.....	84
X-ray Images.....	86
view type.....	67,73
3D.....	78
Objects.....	78
Planes.....	78
viewing options.....	275
Viewing Options tab.....	276
Volumetric Fusion.....	157
volumetric image fusion.....	157

## W

WEEE.....	10
windowing	
advanced.....	68,74,287
basic.....	68
exported data sets.....	307
windowing settings.....	286
workflow.....	58
Workflows	
Framebased.....	49
Frameless.....	53

## X

x-ray images.....	86
-------------------	----

## Z

Zoom In/Out images.....	68
-------------------------	----









brainlab.com

Art-No. 60914-67EN

